

CHURCHILL WAY OUTFALL STABILIZATION

CAPITAL PROJECT # D-1158

CLIENT
 HOWARD COUNTY
 STORMWATER MANAGEMENT DIVISION
 6751 GATEWAY DRIVE, SUITE 514
 COLUMBIA, MD 21046
 PHONE: (410) 313-6413

LEGEND

EXISTING	PROPOSED
--- MAJOR CONTOUR	--- 425 MAJOR CONTOUR
--- MINOR CONTOUR	--- 424 MINOR CONTOUR
SS SANITARY SEWER	--- BOTTOM OF TRAPEZOIDAL CHANNEL
SD STORM DRAIN	--- TOP OF TRAPEZOIDAL CHANNEL
W WATER SUPPLY	--- STREAM CENTERLINE
OHE OVERHEAD ELECTRIC	--- LOD LIMIT OF DISTURBANCE
UGE UNDERGROUND ELECTRIC	--- SSF SUPER SILT FENCE
G GAS	--- FL-18 18-INCH FILTER LOG
100YR EXISTING 100 YEAR FLOODPLAIN	⊗ TREE REMOVAL
~ TREELINE	⊙ TREE PLANKING
--- PROPERTY LINE (GIS)	▨ STAGING AND STOCKPILING AREA
--- ROAD EDGE (GIS)	▩ MULCH ACCESS ROAD
--- BUILDINGS (GIS)	HWM HARDWOOD MATTING
--- STREAM CENTERLINE (GIS)	SCF STABILIZED CONSTRUCTION ENTRANCE
WUS STREAM EXTENTS	⊠ FB FILTER BAG
SB 75' STREAM BUFFER	⊙ PUMP
GbC SOIL BOUNDARIES	--- INTAKE/DISCHARGE HOSE
UaF	⊙ SAND BAG DIKES
HIGHLY ERODIBLE SOILS (15% - 19.99% OR Kw > 0.35 WITH SLOPE > 5%)	
STEEP SLOPES (20% OR GREATER SLOPES)	
⊙ TREE	
△ TRAVERSE POINT	
● WOOD POST	
⊙ STORMDRAIN MANHOLE	
⊙ GAS METER	
⊙ SEWER MANHOLE	
⊙ TELCO MANHOLE	
⊙ SIGN	
⊙ ELECTRIC MANHOLE	
⊙ MAILBOX	

VICINITY MAP

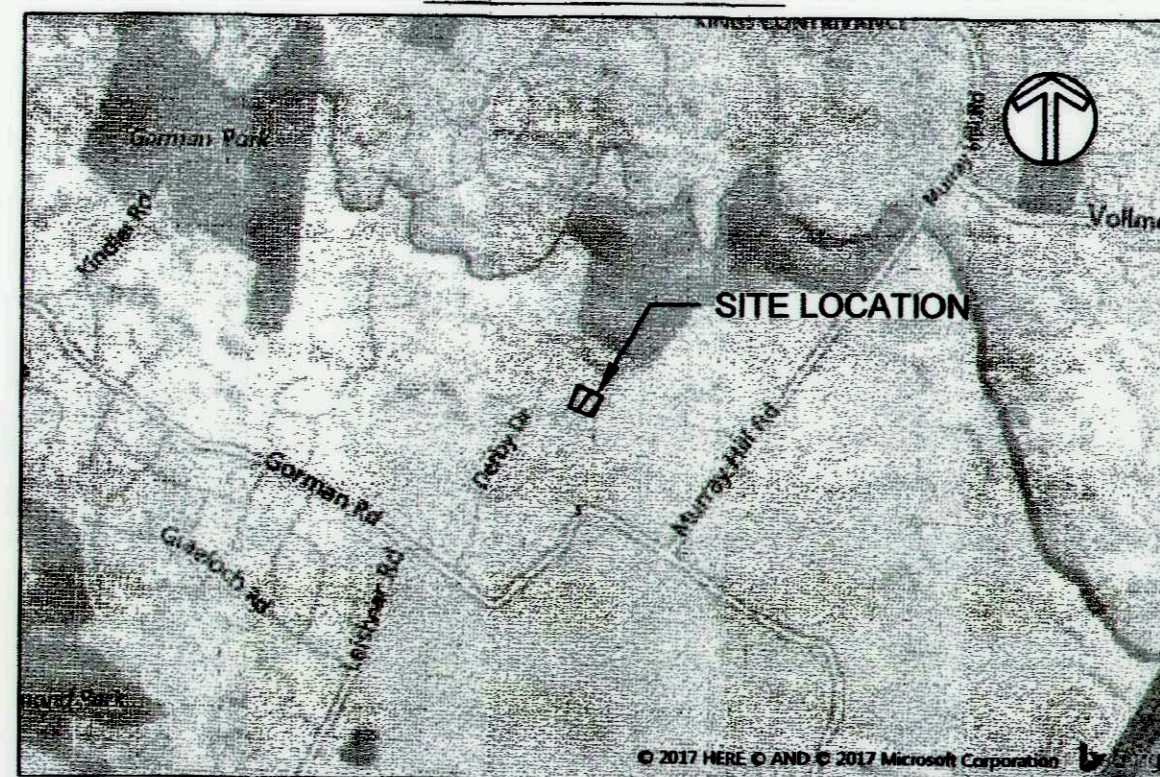

ADC MAP COORDINATES:
 MAP: 19 LETTER: F, G NUMBER: 4, 4 0 1000 2000

DESIGN NARRATIVE:
 CHURCHILL WAY OUTFALL STABILIZATION DESIGN WAS COMPLETED WITH THE FOLLOWING IN MIND:

- OUTFALL STABILIZATION IS PROPOSED WITHIN THE LIMITS OF THE EXISTING OUTFALL CHANNEL TO STABILIZE AND IMPROVE THE EXISTING ERODING CHANNEL. MAJOR IMPACTS TO EXISTING TREES WERE AVOIDED AND MINIMIZED TO THE EXTENT POSSIBLE. NO WETLANDS AND/OR WETLAND BUFFERS ARE WITHIN THE PROJECT EXTENTS.
- ALL PROPOSED GRADING MAINTAINS NATURAL FLOW PATTERNS OF THE OUTFALL CHANNEL AND SURROUNDING FLOODPLAIN FLOWING INTO THE DOWNSTREAM UNNAMED TRIBUTARY THAT FLOWS AND DISCHARGES THE MIDDLE PATUXENT RIVER.
- NO CHANGES IN IMPERVIOUS COVER OR NON-IMPERVIOUS AREAS ARE PROPOSED.
- EROSION AND SEDIMENT CONTROLS INCLUDING STANDARD FILTERING PRACTICES AND CLEAN WATER DIVERSION (PUMP AROUND) WILL BE PROPERLY IMPLEMENTED TO CONTROL ALL SEDIMENT LADEN RUNOFF FROM THE CONSTRUCTION SITE AND PROTECT ALL DOWNSTREAM BODIES OF WATER IN ACCORDANCE WITH THE 2011 MARYLAND STANDARDS AND SPECIFICATIONS FOR SOIL EROSION AND SEDIMENT CONTROL. SWM IS NOT REQUIRED FOR THIS OUTFALL STABILIZATION PROJECT.
- NO ESD PRACTICES ARE BEING IMPLEMENTED.
- ALL EXISTING TREE LINES WILL BE REESTABLISHED WITH NATIVE VEGETATION.

SITE ANALYSIS DATA:

- TOTAL PROJECT AREA = 0.3 AC
- WETLAND TOTAL AREA = 0.0 AC
- WETLAND BUFFER TOTAL AREA = 0.0 AC
- FLOODPLAIN AREA = 0.0 AC
- FOREST AREA = 0.0 AC
- STEEP SLOPES AREA = 0.1 AC
- ERODIBLE SOILS AREA = 0.1 AC
- DISTURBED AREA = 0.3 AC
- PROPOSED SITE USE = FLOODPLAIN FOREST
- PROPOSED IMPERVIOUS AREA = 0.0 AC

PT #	NORTHING	EASTING	ELEVATION
51	542209.475'	1350903.670'	340.92'
100	542242.022'	1351073.256'	328.58'
101	542006.416'	1351037.708'	317.63'
102	542103.680'	1350870.461'	344.92'

Property Owners	Deed	Mtg	Parcel	Plat No.
BOARD OF COUNTY COMM HOWARD COUNTY (HOWARD COUNTY PARKS BOARD)	497/201	42	379	-
BROOKS CHARLES D TRUSTEE AND LAURE W TRUSTEE	13846/34	42	81	8563
DOVE RANDOLPH V AND JOANNA S T/E	3922/694	42	81	8563
DIARTE FERNANDO AND LAURA M T/E	6115/236	42	81	8563
FITZGERALD EDWARD T JR AND LALWANEE KIRAN	1730/10	42	81	8563
FLYNN LAURA M AND BRENT A	13428/235	42	81	8563
GREER BROOK C AND KERRY B T/E	2832/709	42	81	8563
GRIEGO EDWIN V AND SANDRA D	16856/265	42	81	8563
HOWARD COUNTY, MARYLAND DEPARTMENT OF REC AND PARKS	1910/535	42	81	8563
HOWARD COUNTY, MARYLAND DEPARTMENT OF REC AND PARKS	1987/21	42	81	8563
MILLER MARY ANN	2661/330	42	81	8563
MYERS LEE H AND ELIZABETH A	2638/562	42	81	8563
NOLEN JOHN M AND SKELLY NOLEN MARGARET A T/E	2560/553	42	81	8563
ROMEO THOMAS D JR AND CATHY C T/E	3437/168	42	81	8563
VINING DIANE I	11217/593	42	81	8563

Sheet #	Sheet Title
1	TITLE SHEET AS-BUILT
2	EXISTING CONDITIONS
3	PROPOSED CONDITIONS AS-BUILT
4	PROFILE
5	EROSION AND SEDIMENT CONTROL
6	EROSION AND SEDIMENT CONTROL DETAILS
7	EROSION AND SEDIMENT CONTROL DETAILS
8	EROSION AND SEDIMENT CONTROL DETAILS
9	EROSION AND SEDIMENT CONTROL NOTES

GENERAL NOTES

- ALL CONSTRUCTION SHALL BE IN ACCORDANCE WITH THE LATEST STANDARDS AND SPECIFICATIONS OF HOWARD COUNTY PLUS MSHA STANDARDS AND SPECIFICATIONS IF APPLICABLE.
- THE EXISTING INFORMATION SHOWN ON THESE PLANS WAS TAKEN FROM THE BEST AVAILABLE SOURCES AND SHALL BE VERIFIED BEFORE STARTING CONSTRUCTION. HOWARD COUNTY DOES NOT GUARANTEE THE COMPLETENESS OR THE CORRECTNESS OF THE SHOWN INFORMATION.
- THE CONTRACTOR IS SOLELY RESPONSIBLE FOR CONSTRUCTION MEANS, METHODS, TECHNIQUES, SEQUENCES, PROCEDURES, AND SAFETY PRECAUTIONS AND PROGRAMS.
- THE CONTRACTOR SHALL NOTIFY THE DEPARTMENT OF PUBLIC WORKS/BUREAU OF ENGINEERING/CONSTRUCTION INSPECTION DIVISION AT (410) 313-1880 AT LEAST FIVE (5) DAYS PRIOR TO THE START OF WORK.
- THE CONTRACTOR SHALL NOTIFY "MISS UTILITY" AT 1-800-257-7777 AT LEAST FIVE (5) WORKING DAYS PRIOR TO ANY EXCAVATION WORK BEING DONE.
- PRIOR TO BEGINNING ANY CONSTRUCTION ACTIVITIES, PHOTOGRAPHS OF THE PROPOSED WORK AREA AND ACCESS SHALL BE TAKEN.
- A JOINT PERMIT APPLICATION HAS BEEN SUBMITTED AND APPROVED BY THE MARYLAND DEPARTMENT OF THE ENVIRONMENT FOR THIS PROJECT (CENAB-OP-RMN (HO SVM/CHURCHILL CHANNEL STABILIZATION) 2017-61366). PROJECT IMPACTS INCLUDE WORK IN A USE IV-P STREAM. UNDER THIS PERMIT, IN-STREAM WORK IS PROHIBITED FROM MARCH 1 TO MAY 31, INCLUSIVE OF ANY YEAR.
- THE EXISTING TOPOGRAPHY WAS TAKEN FROM FIELD RUN SURVEY WITH ONE FOOT CONTOUR INTERVALS PREPARED BY AB CONSULTANTS, INC. IN DECEMBER 2016.
- THE COORDINATES SHOWN HEREON ARE BASED UPON THE HOWARD COUNTY GEODETIC CONTROL, WHICH IS BASED UPON THE MARYLAND STATE PLANE COORDINATE SYSTEM. HOWARD COUNTY MONUMENT NOS. 37BC AND 37BA WERE USED FOR THIS PROJECT.
- WATER IS PUBLIC.
- SEWER IS PUBLIC.
- 100-YEAR FLOODPLAIN ELEVATION IS SHOWN ON THE PLANS. THERE ARE NO FEMA MAPPED FLOODPLAINS WITHIN THE PROJECT LIMITS. DUE TO THE SHORT LENGTH OF THE PROJECT, A HYDRAULIC ANALYSIS WAS NOT CONDUCTED; THE FLOODPLAIN SHOWN ON THE PLANS WAS ESTIMATED FOR THE OUTFALLING STREAM AS FLOODPRONE AREA GIVEN A BANKFULL HEIGHT OF 1.5 FT.
- THE STREAM IS NOT A TIER II WATER. AS A TRIBUTARY TO MIDDLE PATUXENT RIVER WITHIN THE MIDDLE PATUXENT RIVER WATERSHED, THE STREAM IS NOT AN IMPAIRED WATERWAY.
- TEMPORARY STAGING AND/OR STOCKPILING OF ERODIBLE MATERIALS (E.G. EXCAVATED MATERIAL) WITHIN THE 100-YEAR FLOODPLAIN DESIGNATED ON THE PLANS SHALL BE LIMITED TO THE AMOUNT OF MATERIAL THE CONTRACTOR CAN PLACE AND/OR HAUL OFF IN A SINGLE DAY. THE CONTRACTOR SHALL MONITOR THE WEATHER FORECAST AND ADJUST STOCKPILE/STAGING OPERATIONS ACCORDINGLY TO MINIMIZE THE LOSS OF MATERIAL OR OTHER ADVERSE IMPACTS.
- THE CONTRACTOR SHALL NOT STORE EQUIPMENT, MATERIALS, AND/OR SUPPLIES BEYOND THE LIMIT OF DISTURBANCE SHOWN ON THE PLANS.
- EXISTING UTILITIES ARE BASED ON AVAILABLE RECORDS. THE CONTRACTOR MUST VERIFY INFORMATION TO HIS/HER SATISFACTION.
- THERE ARE NO WETLANDS LOCATED ON THE PROJECT SITE.
- NO TRAFFIC STUDY IS REQUIRED FOR THIS PROJECT.
- THERE ARE NO BURIAL GROUNDS OR CEMETERY SITES LOCATED ON THE PROJECT SITE.
- THE CONTRACTOR SHALL TAKE ALL NECESSARY PRECAUTIONS TO PROTECT THE EXISTING UTILITIES AND MAINTAIN UNINTERRUPTED SERVICE. ANY DAMAGE INCURRED DUE TO THE CONTRACTOR'S OPERATION SHALL BE REPAIRED IMMEDIATELY AT THE CONTRACTOR'S EXPENSE. ALL UTILITIES SHALL HAVE A CLEARANCE BY A MINIMUM OF 6 INCHES VERTICALLY AND A MINIMUM OF 5 FEET HORIZONTALLY.
- THE CONTRACTOR SHALL EXERCISE CARE IN ALL ACTIVITIES INVOLVING EITHER CUT AND FILL OR GRADING IN THE VICINITY OF TREES THAT ARE TO REMAIN. ALL EARTH CUTS AND ACTIVITIES IN THE VICINITY OF TREES TO REMAIN SHALL BE MADE IN A MANNER THAT DOES NOT DISTURB THE CRITICAL ROOT ZONE WITHIN THE DRIPLINE OF THE TREE. TREES TO BE SAVED SHALL BE LOCATED AND SAVED WITH THE ENGINEER ON-SITE PRIOR TO CONSTRUCTION.
- UPON COMPLETION OF THE WORK, BUT PRIOR TO DE-MOBILIZATION, THE CONTRACTOR SHALL REMOVE ALL REMNANTS OF CONSTRUCTION MATERIALS FROM THE SITE. THE CONTRACTOR SHALL RESTORE ALL DISTURBED AREAS TO A CONDITION EQUAL OR BETTER THAN THE PRE-CONSTRUCTION CONDITIONS.
- BIOHABITATS SHALL CERTIFY IN WRITTEN LETTER THAT THE CONSTRUCTION ACTIVITIES HAVE BEEN COMPLETED IN ACCORDANCE TO THESE PLANS.
- TEMPORARY DISTURBANCE WITHIN THE 75' PERENNIAL STREAM BUFFER, STREAM CHANNEL, AND 100-YR FLOODPLAIN, ARE NECESSARY FOR CONSTRUCTION OF THE OUTFALL STABILIZATION PROJECT IN ACCORDANCE WITH SECTION 16.116(C) OF THE SUBDIVISION AND LAND DEVELOPMENT REGULATION.

Map Unit Symbol	Map Unit Name	K Photo (Whole Soil)	Hydric Rating	Hydrologic Soil Group	Highly Erodible	Management Class
GcB	Gleysol loam, 3 to 8 percent slopes	0.20	Non-Hydric	B	NO	Well Drained
GhB	Gleysol-Urban land complex, 0 to 8 percent slopes	0.20	Non-Hydric	B	NO	Well Drained
GnB	Gleysol-Silt all loams, 0 to 8 percent slopes	0.37	Hydric	C	YBS	Moderately Well Drained
MnC	Mesor loam, 8 to 15 percent slopes	0.24	Non-Hydric	B	NO	Well Drained
MdD	Mesor loam, 15 to 25 percent slopes	0.24	Non-Hydric	B	NO	Well Drained

DEPARTMENT OF PUBLIC WORKS, HOWARD CO, MD

Jan 7 10/25/17
 DIRECTOR, DEPARTMENT OF PUBLIC WORKS DATE

Mark DeLuca 10/19/17
 CHIEF, BUREAU OF ENVIRONMENTAL SERVICES DATE

Mark DeLuca 10/19/17
 CHIEF, STORMWATER MANAGEMENT DIVISION DATE

DEPARTMENT OF RECREATION AND PARKS, HOWARD CO, MD

John R. Boyd 10/20/17
 DIRECTOR OF RECREATION AND PARKS DATE

ENGINEERS CERTIFICATE

"I CERTIFY THAT THIS PLAN FOR SEDIMENT AND EROSION CONTROL REPRESENTS A PRACTICAL AND WORKABLE PLAN BASED ON MY PERSONAL KNOWLEDGE OF THE SITE CONDITIONS AND THAT IT WAS PREPARED IN ACCORDANCE WITH THE REQUIREMENTS OF THE HOWARD COUNTY SOIL CONSERVATION DISTRICT"

Brett Long 10-18-2017
 SIGNATURE OF ENGINEER (PRINT NAME BELOW SIGNATURE) DATE

DEVELOPERS CERTIFICATE

"I/WE CERTIFY THAT ALL DEVELOPMENT AND CONSTRUCTION WILL BE DONE ACCORDING TO THIS PLAN FOR SEDIMENT AND EROSION CONTROL, AND THAT ALL RESPONSIBLE PERSONNEL INVOLVED IN THE CONSTRUCTION PROJECT WILL HAVE A CERTIFICATE OF ATTENDANCE AT A DEPARTMENT OF THE ENVIRONMENT APPROVED TRAINING PROGRAM FOR THE CONTROL OF SEDIMENT AND EROSION BEFORE THE BEGINNING OF THE PROJECT. I ALSO AUTHORIZE PERIODIC ON-SITE INSPECTION BY THE HOWARD COUNTY SOIL CONSERVATION DISTRICT"

Jan 7 10/25/17
 SIGNATURE OF DEVELOPER (PRINT NAME BELOW SIGNATURE) DATE

AS-BUILT LEGEND

--- CHANNEL CENTERLINE

--- MAJOR CONTOUR

--- MINOR CONTOUR

▭ RIPRAP OUTFALL PROTECTION (EXTENTS OUTLINED)

This development plan is approved for soil erosion and sediment control by the HOWARD SOIL CONSERVATION DISTRICT

Jan 7 10/20/17
 HOWARD SCD DATE

STATE OF MARYLAND
 BRETT V. LONG
 PROFESSIONAL ENGINEER
 LICENSE NO. 38617

PROFESSIONAL CERTIFICATION 10-18-2017

I HEREBY CERTIFY THAT THESE DOCUMENTS WERE PREPARED OR APPROVED BY ME, AND THAT I AM A DULY LICENSED PROFESSIONAL ENGINEER UNDER THE LAWS OF THE STATE OF MARYLAND.

LICENSE #: 38617
 EXPIRATION DATE: 06/03/2018

CHURCHILL WAY OUTFALL STABILIZATION

SITE ADDRESS: 10430 CHURCHILL WAY, LAUREL, MD
 ZONING: R-20 TAX MAP/GRID/PARCEL: 0042/0019/0081
 ELECTION DISTRICT: 06 HOWARD COUNTY OPEN SPACE

TITLE SHEET

PROJECT NO. 13005.47	SCALE: NTS
SEAL: BY: KT CHECK: MDT/EVL	DWG NO.:
1 OF 9	

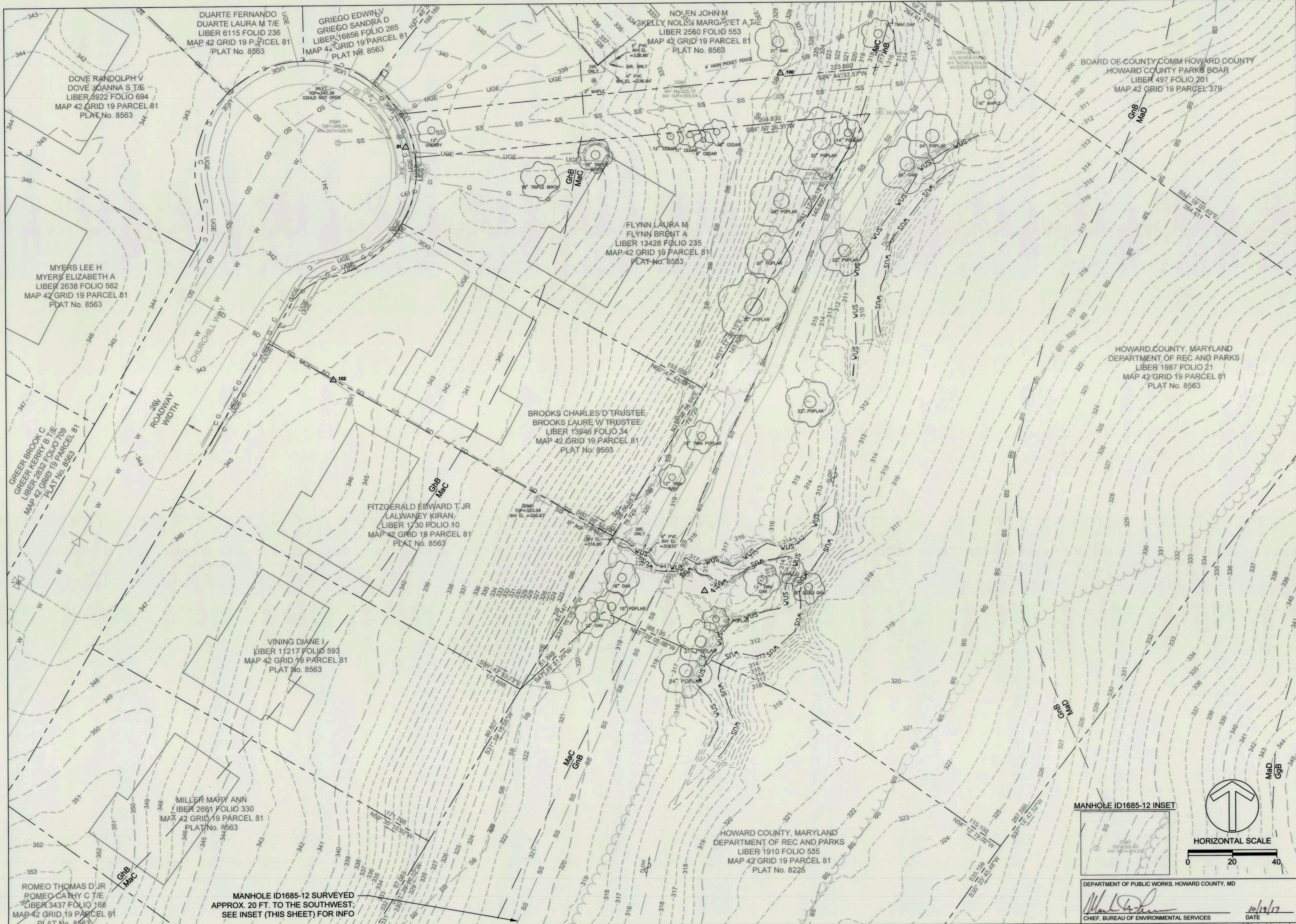

CLIENT
 HOWARD COUNTY
 STORMWATER MANAGEMENT DIVISION
 6751 GATEWAY DRIVE, SUITE 514
 COLUMBIA, MD 21046
 PHONE: (410) 313-6413

DATE	ISSUES / REVISIONS

Biohabitats
 The Stables Building 2081 Clipper Park Road
 Baltimore, MD 21211 / ph: 410.554.0156
 fx: 410.554.0168 / www.biohabitats.com
Restore the Earth & Inspire Ecological Stewardship

CHURCHILL WAY OUTFALL STABILIZATION

SITE ADDRESS: 10430 CHURCHILL WAY, LAUREL, MD
 ZONING: R-20 TAX MAP GRID/PARCEL: 0042/0019/0081
 ELECTION DISTRICT: 06 HOWARD COUNTY OPEN SPACE

EXISTING CONDITIONS

PROJECT NO. : 13005.47	SCALE: 1" = 20'
SEAL	BY: KT CHECK: MDT/BVL
	DWG. NO. : 2 OF 9
	DATE: 10/19/17

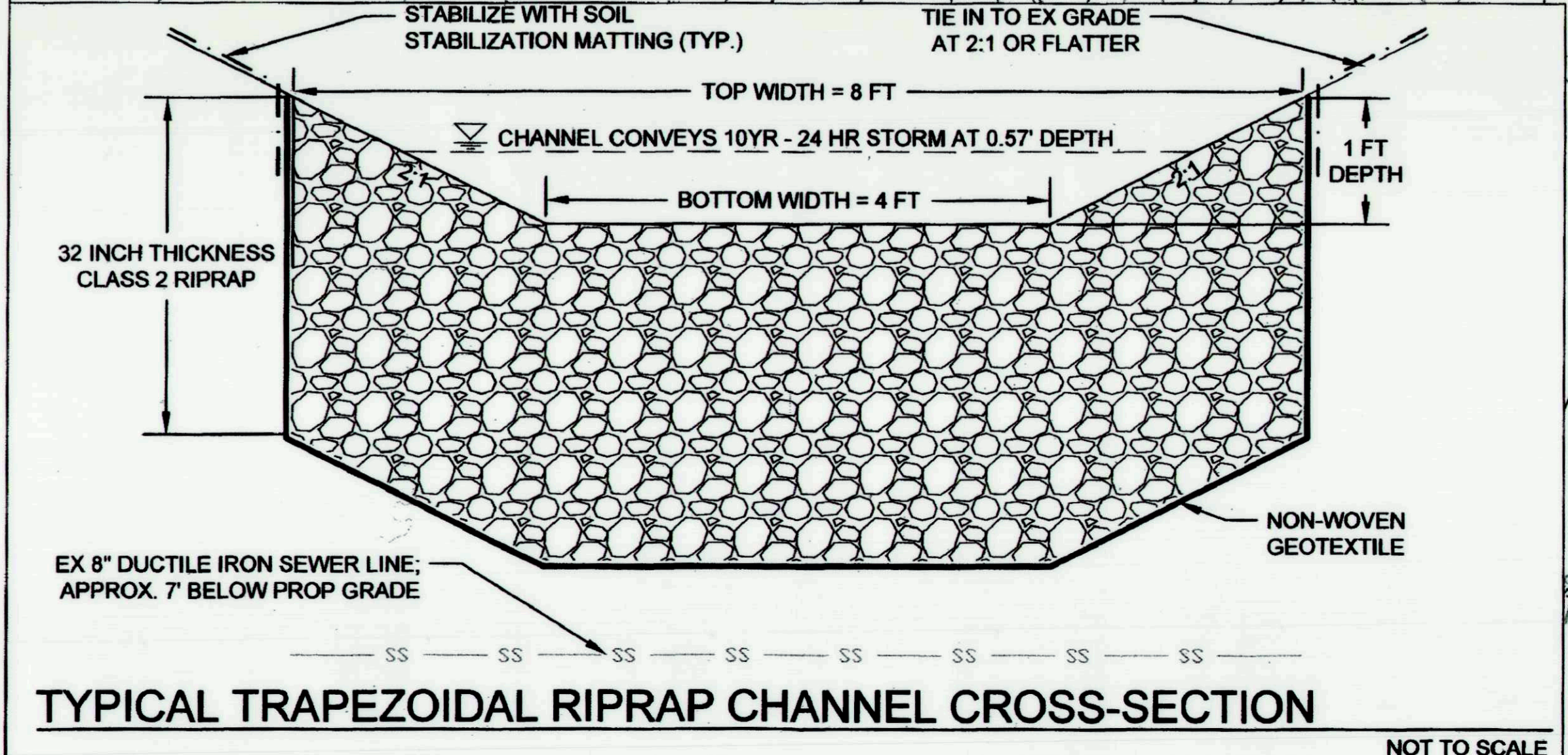
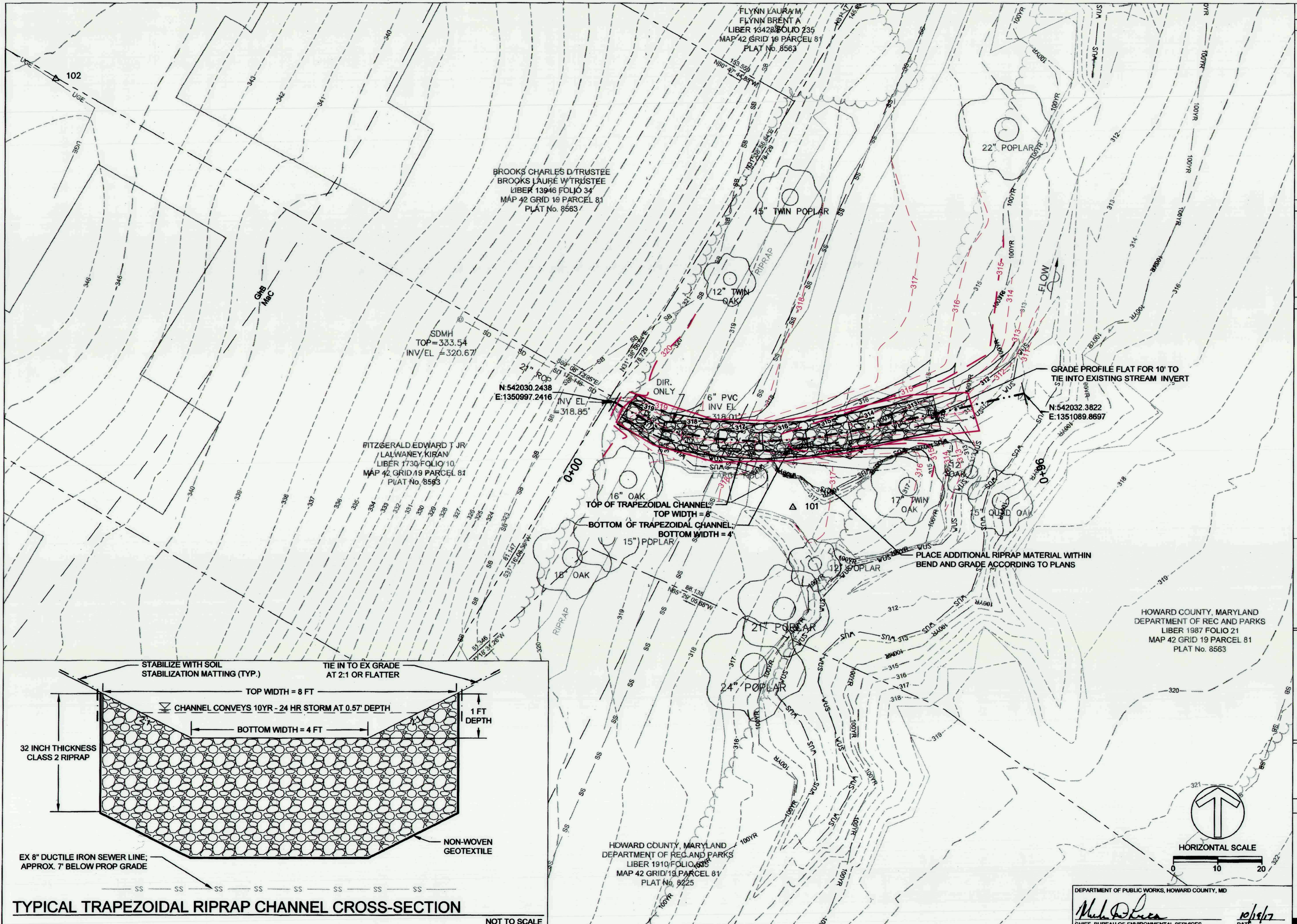

CLIENT
 HOWARD COUNTY
 STORMWATER MANAGEMENT DIVISION
 6751 GATEWAY DRIVE, SUITE 514
 COLUMBIA, MD 21046
 PHONE: (410) 313-8413

DATE ISSUES / REVISIONS



AS BUILT CERTIFICATION
 I HEREBY CERTIFY, BY MY SEAL, THAT TO THE BEST OF MY KNOWLEDGE AND BELIEF THE FACILITIES SHOWN ON THIS PLAN WERE CONSTRUCTED AS SHOWN ON THIS "AS-BUILT" PLAN MEET THE APPROVED PLANS AND SPECIFICATIONS.

Brett J. Long 6-13-2018
 NAME DATE

Biohabitats
 The Stables Building 2081 Clipper Park Road
 Baltimore, MD 21211 / ph: 410.554.0156
 fx: 410.554.0168 / www.biohabitats.com
 Restore the Earth & Inspire Ecological Stewardship

**CHURCHILL WAY
 OUTFALL
 STABILIZATION**

SITE ADDRESS: 10430 CHURCHILL WAY, LAUREL, MD
 ZONING: R-20 TAX MAP GRID/PARCEL: 004200190001
 ELECTION DISTRICT: 06 HOWARD COUNTY OPEN SPACE

**PROPOSED
 CONDITIONS**

PROJECT NO.: 13005.47 SCALE: 1" = 10'
 SEAL: BY: KT CHECK: MDT/BVL
 DWS NO.:



3 OF 9

DEPARTMENT OF PUBLIC WORKS, HOWARD COUNTY, MD
 Michael P. Lucas 10/18/17
 CHIEF, BUREAU OF ENVIRONMENTAL SERVICES DATE

CLIENT
 HOWARD COUNTY
 STORMWATER MANAGEMENT DIVISION
 6751 GATEWAY DRIVE, SUITE 514
 COLUMBIA, MD 21046
 PHONE: (410) 313-6413

PROFILE VIEW OF RIPRAP TRAPEZOIDAL CHANNEL

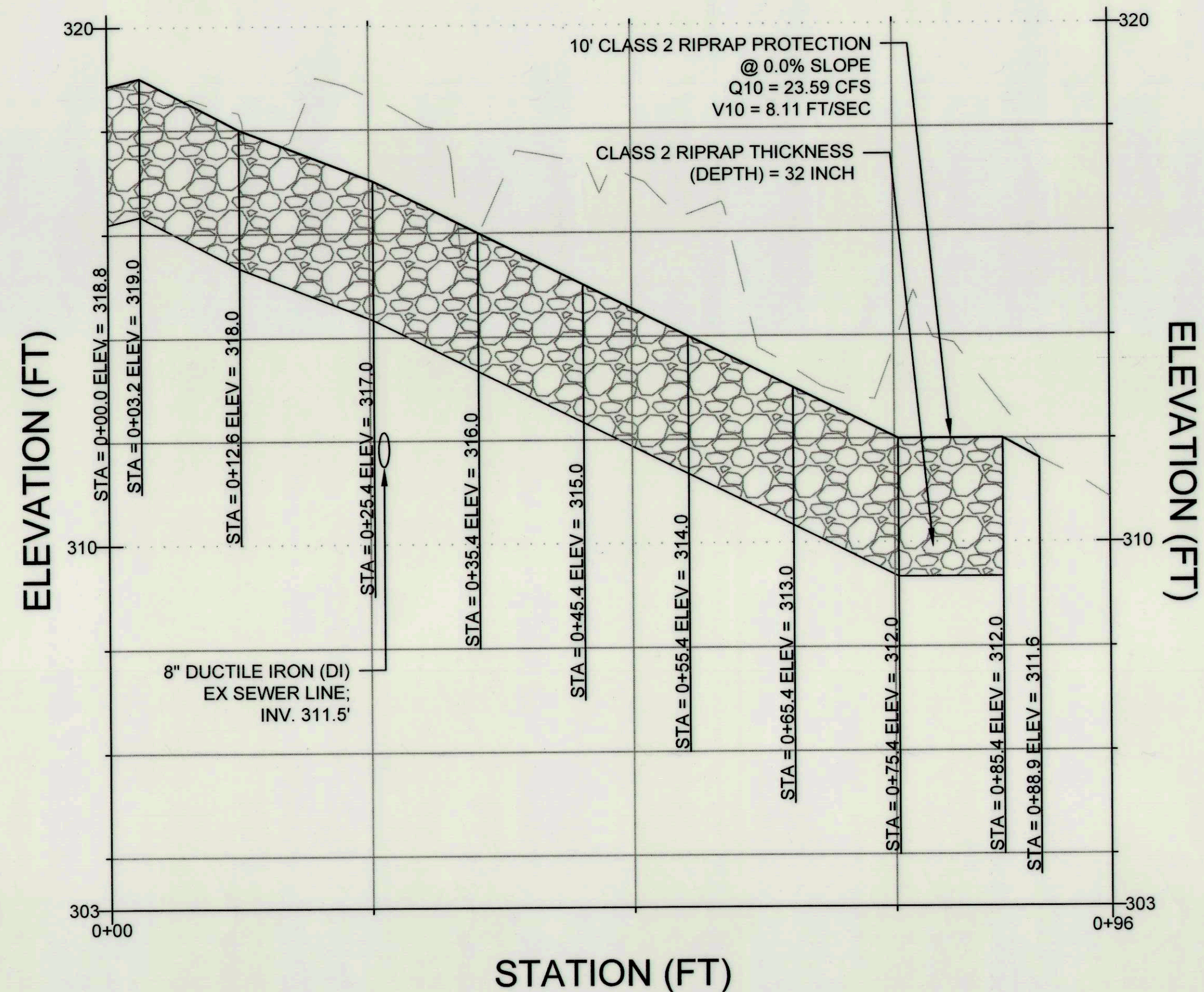

DATE	ISSUES / REVISIONS

Biohabitats
 The Stables Building 2081 Clipper Park Road
 Baltimore, MD 21211 / ph: 410.554.0156
 fx: 410.554.0168 / www.biohabitats.com
Restore the Earth & Inspire Ecological Stewardship

**CHURCHILL WAY
 OUTFALL
 STABILIZATION**

SITE ADDRESS: 10430 CHURCHILL WAY, LAUREL, MD
 ZONING: R-20 TAX MAP/GRID/PARCEL: 00420019/0081
 ELECTION DISTRICT: 06 HOWARD COUNTY OPEN SPACE

PROFILE

PROJECT NO.: 13005.47 SCALE: AS SHOWN

SEAL BY: KT CHECK: MDT/BVL

DWG NO.:

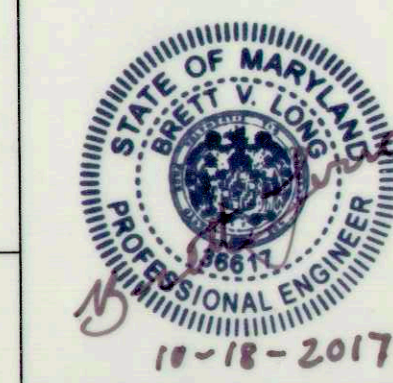

4 OF 9

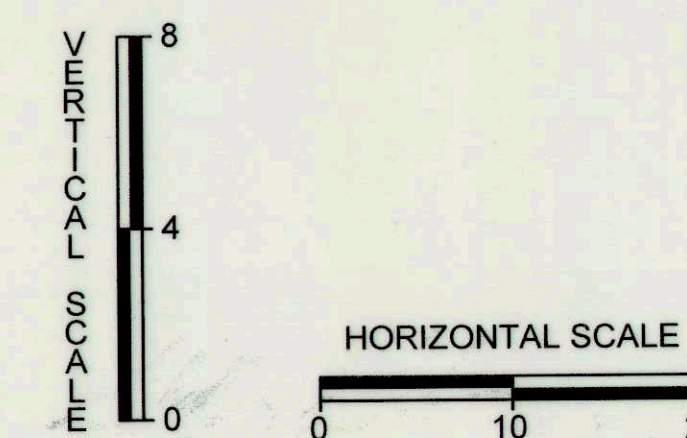

DEPARTMENT OF PUBLIC WORKS, HOWARD COUNTY, MD

Mark D. ...
 CHIEF, BUREAU OF ENVIRONMENTAL SERVICES DATE: 10/19/17

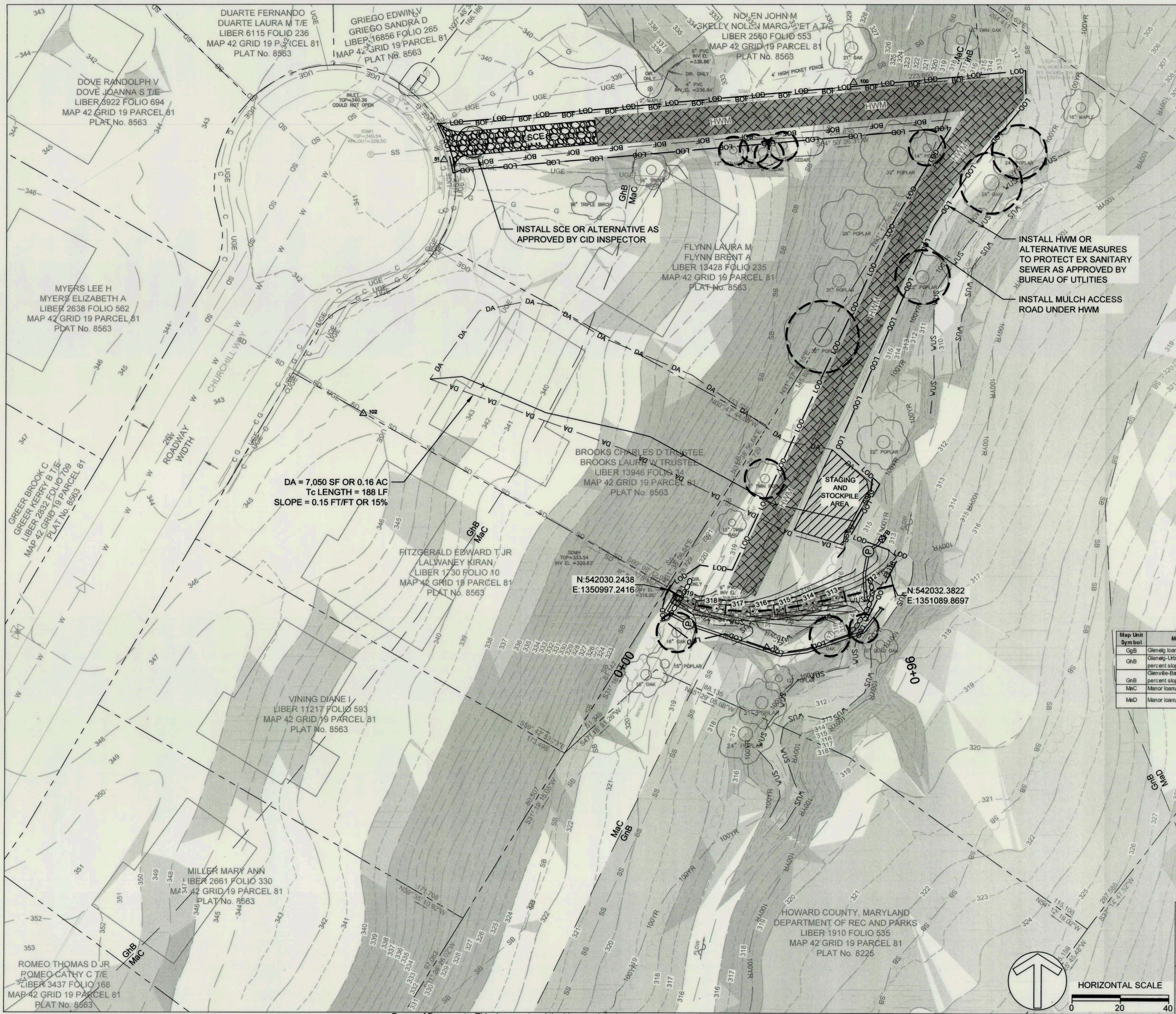

- ESC LEGEND**
- EXISTING**
- 100YR EXISTING 100 YR FLOODPLAIN
 - TREELINE
 - STREAM CENTERLINE (GIS)
 - WUS STREAM EXTENTS
 - SB 75' STREAM BUFFER
 - GbC SOIL BOUNDARIES
 - UaF
 - HIGHLY ERODIBLE SOILS (15% - 19.99% OR Kw > 0.35 WITH SLOPE > 5%)
 - STEEP SLOPES (20% OR GREATER SLOPES)
 - TREE
- PROPOSED**
- 425 MAJOR CONTOUR
 - 424 MINOR CONTOUR
 - BOTTOM OF TRAPEZOIDAL CHANNEL
 - TOP OF TRAPEZOIDAL CHANNEL
 - STREAM CENTERLINE
 - LOD LIMIT OF DISTURBANCE
 - SSF SUPER SILT FENCE
 - FL-18 18-INCH FILTER LOG
 - TREE REMOVAL
 - TREE PLANKING
 - STAGING AND STOCKPILE AREA
 - MULCH ACCESS ROAD
 - HWM HARDWOOD MATTING
 - SCE STABILIZED CONSTRUCTION ENTRANCE
 - FB FILTER BAG
 - P PUMP
 - INTAKE/DISCHARGE HOSE
 - SAND BAG DIKES

Map Unit Sym bol	Map Unit Name	K-Factor (Whole Soil)	Hydric Rating	Hydrologic Soil Group	Highly Erodible	Drainage Class
GyB	Glenelig loam, 3 to 8 percent slopes	0.20	Non-Hydric	B	NO	Well Drained
GhB	Glenelig-Urban land complex, 0 to 8 percent slopes	0.20	Non-Hydric	B	NO	Well Drained
GnB	Glenville-Baile silt loams, 0 to 8 percent slopes	0.37	Hydric	C	YES	Moderately Well Drained
MeC	Manor loam, 8 to 15 percent slopes	0.24	Non-Hydric	B	NO	Well Drained
MeD	Manor loam, 15 to 25 percent slopes	0.24	Non-Hydric	B	NO	Well Drained

CLIENT
 HOWARD COUNTY
 STORMWATER MANAGEMENT DIVISION
 6751 GATEWAY DRIVE, SUITE 514
 COLUMBIA, MD 21046
 PHONE: (410) 313-6413

DATE	ISSUES / REVISIONS

Biohabitats
 The Stables Building 2081 Clipper Park Road
 Baltimore, MD 21211 / ph: 410.554.0156
 fx: 410.554.0168 / www.biohabitats.com
Restore the Earth & Inspire Ecological Stewardship

CHURCHILL WAY OUTFALL STABILIZATION

SITE ADDRESS: 10430 CHURCHILL WAY, LAUREL, MD
 ZONING: R-20 TAX MAP GRID/PARCEL: 00420019/00681
 ELECTION DISTRICT: 06 HOWARD COUNTY OPEN SPACE

EROSION AND SEDIMENT CONTROL

PROJECT NO.: 13005.47 SCALE: 1" = 20'
 SEAL: BY: KT CHECK: MDT/BVL
 DWG NO.:

5 OF 9

This development plan is approved for soil erosion and sediment control by the HOWARD SOIL CONSERVATION DISTRICT
 Howard SCD Date: 10/20/12
 DEPARTMENT OF PUBLIC WORKS, HOWARD COUNTY, MD
 Chief, Bureau of Environmental Services Date: 10/19/12

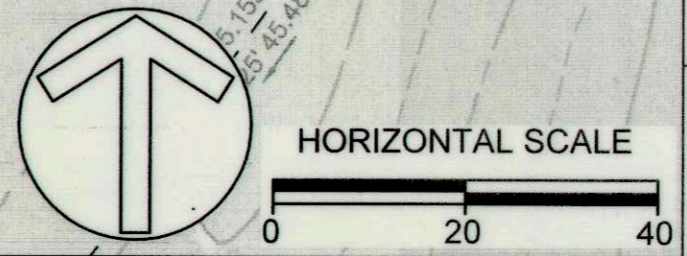

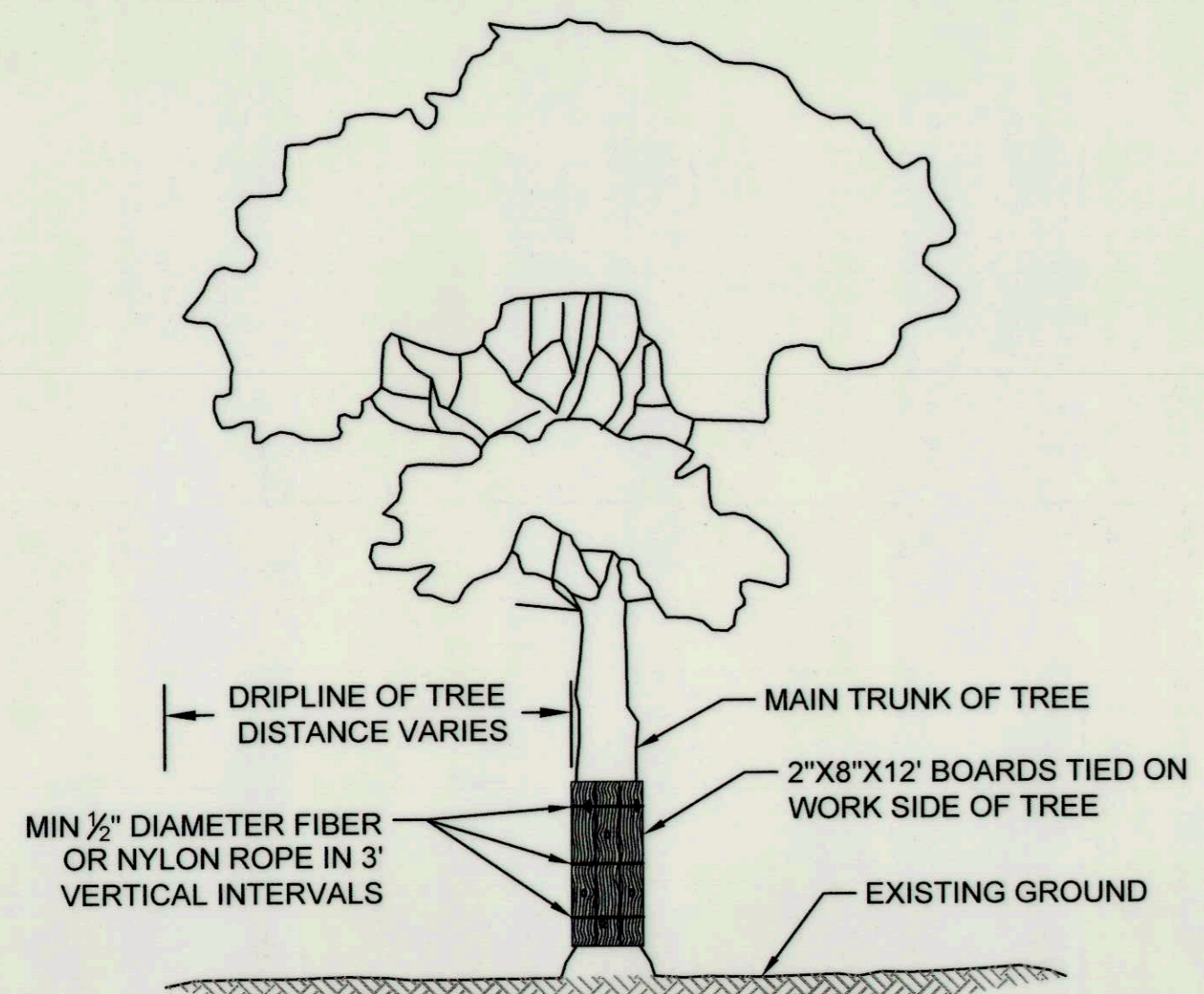

- NOTES:
1. TIE SUFFICIENT 2"x8"x12' BOARDS AROUND MAIN TRUNK OF TREE WITH 1/2" DIAMETER ROPE (FIBER OR NYLON) TO PROTECT ALL AREAS EXPOSED TO CONSTRUCTION.
 2. INSTALL WIRE EYE BOLTS WITH MINIMUM INNER DIAMETER OF 5/8" AND MINIMUM LENGTH OF 4" FIRMLY IN EACH PLANK WHERE FIBER OR NYLON ROPES CROSS OVER PLANKS.
 3. WHERE SIGNIFICANT TREE BRANCHES EXIST WHICH PREVENT PLANK INSTALLATION, PLANKING SHALL EXTEND TO THE ELEVATION OF THE LOWEST BRANCH.

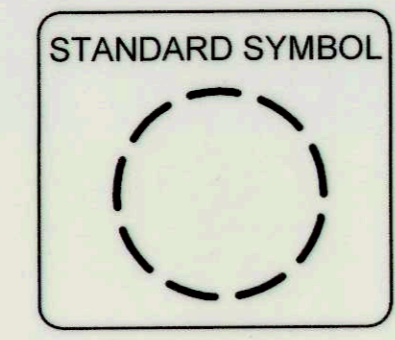

TREE PLANKING

NOT TO SCALE

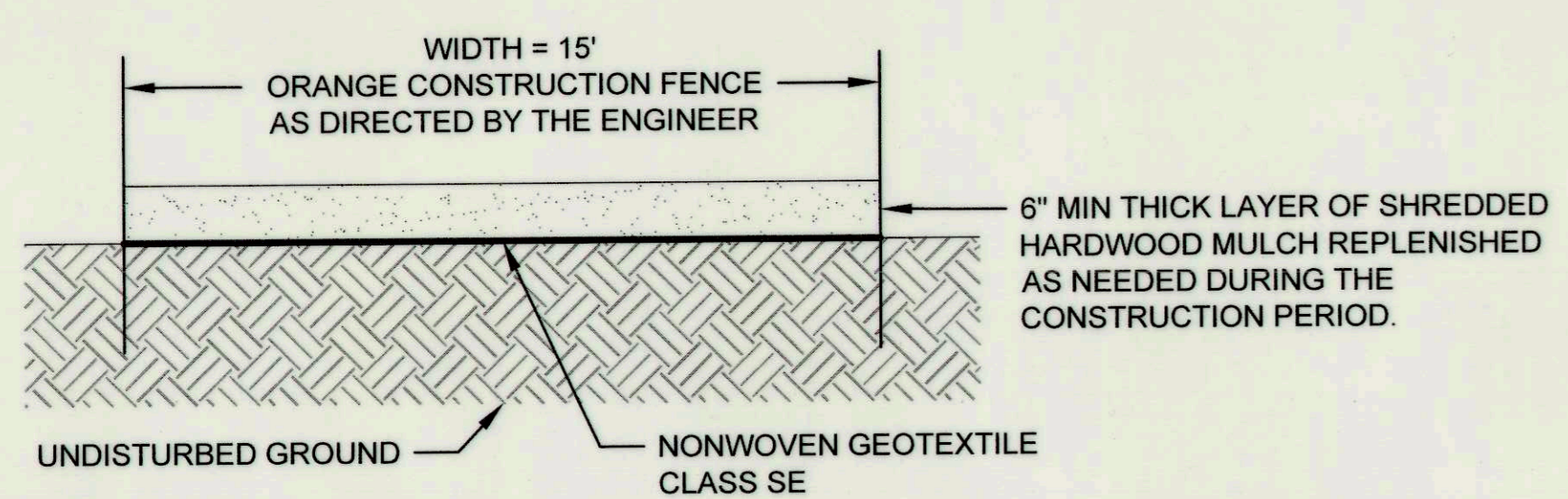

- NOTES:
1. ACCESS ROUTES TO BE VERIFIED BY ENGINEER AT EROSION AND SEDIMENT CONTROL MEETING. REVISIONS TO THE ALIGNMENT THAT MINIMIZE TREE DISTURBANCE ARE ENCOURAGED AND REQUIRE REVIEW AND APPROVAL BY THE ENGINEER.
 2. CONTRACTOR SHALL MAINTAIN MULCH ACCESS PATH THROUGHOUT THE CONSTRUCTION PERIOD. UPON COMPLETION OF PROJECT, ALL MULCH ACCESS ROADS SHALL BE REMOVED AND RESTORED TO PRE-EXISTING CONDITIONS.
 3. SCARIFICATION OF COMPACTED MULCH TO OCCUR UPON REMOVAL OF ACCESS ROAD, AT THE DIRECTION OF THE ENGINEER.
 4. FILTER LOGS TO PLACED ALONG MULCH ACCESS ROAD AS SHOWN ON EROSION AND SEDIMENT CONTROL PLANS.

MULCH ACCESS ROAD

NOT TO SCALE

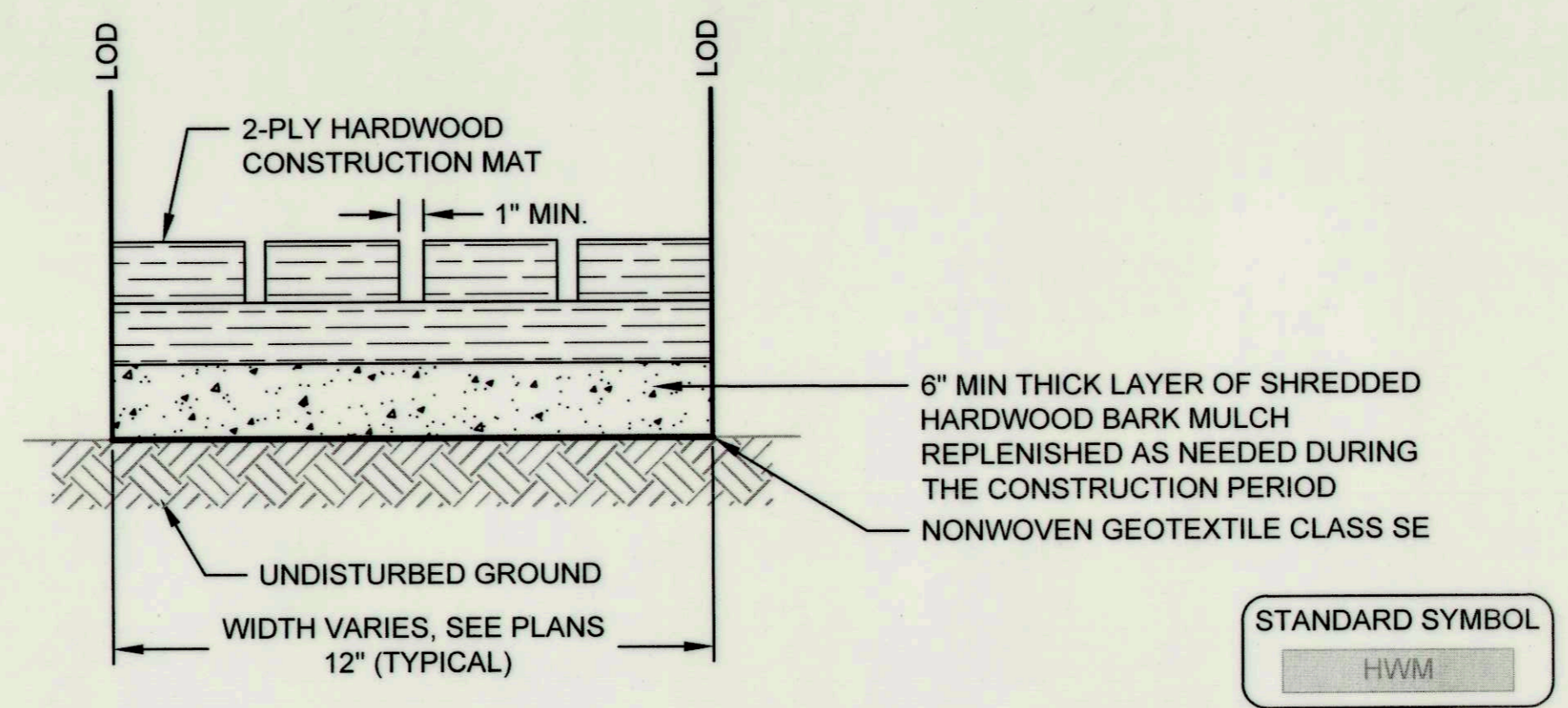

- NOTES:
1. HARDWOOD MATS TO BE INSTALLED AS SHOWN ON THE CONTRACT DOCUMENTS OR AS DIRECTED BY THE ENGINEER.
 2. ACCESS ROUTES TO BE VERIFIED BY THE ENGINEER AT THE EROSION AND SEDIMENT CONTROL MEETING. REVISIONS TO THE ALIGNMENT THAT MINIMIZE TREE DISTURBANCE ARE ENCOURAGED, AND REQUIRE REVIEW AND APPROVAL BY THE ENGINEER.
 3. THE CONTRACTOR SHALL ENSURE THAT EQUIPMENT IS KEPT ON MATS AT ALL TIMES WHERE MATS ARE PRESENT.
 4. THE CONTRACTOR SHALL MAINTAIN MULCH ACCESS ROADS THROUGHOUT THE CONSTRUCTION PERIOD. UPON COMPLETION OF PROJECT, ALL MULCH ACCESS ROADS SHALL BE REMOVED AND RESTORED TO PRE-EXISTING CONDITIONS.

HARDWOOD MAT DETAIL CROSS SECTION

NOT TO SCALE

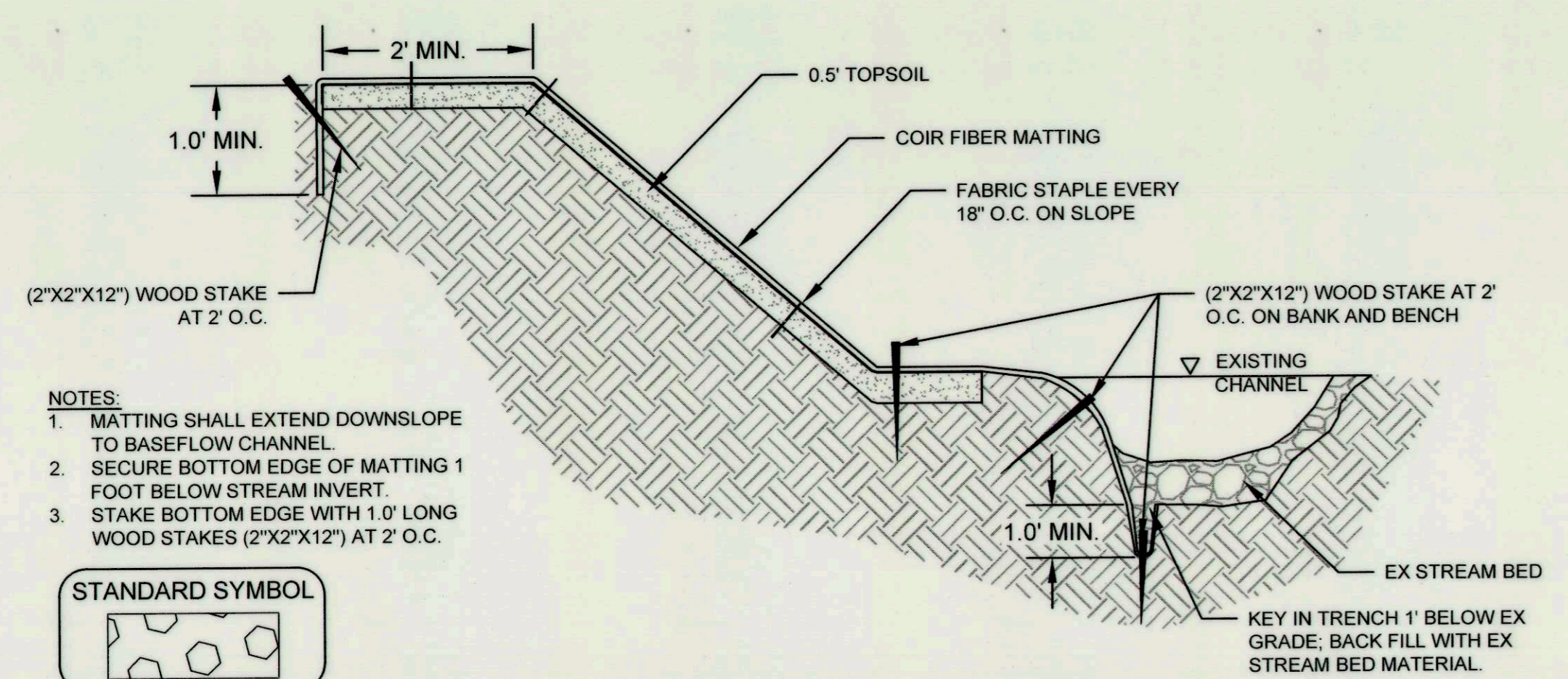

- NOTES:
1. MATTING SHALL EXTEND DOWNSLOPE TO BASEFLOW CHANNEL.
 2. SECURE BOTTOM EDGE OF MATTING 1 FOOT BELOW STREAM INVERT.
 3. STAKE BOTTOM EDGE WITH 1.0' LONG WOOD STAKES (2"x2"x12") AT 2' O.C.

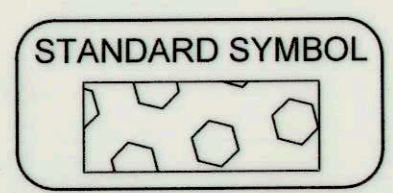

NOTE: COIR FIBER MATTING SHALL BE ROLLED LENGTH WISE ALONG EACH STREAM BANK EXTENDING FROM TOE OF SLOPE TO A MINIMUM OF TWO FEET PAST THE TOP OF SLOPE UPON COMPLETION OF GRADING AND APPLICATION OF HERBACEOUS PERMANENT SEEDING. IF MORE THAN ONE ROLL IS REQUIRED, MID-BANK OVERLAP SHOULD BE A MINIMUM OF ONE FOOT AND SECURELY FASTENED WITH STAPLES. MATTING CAN BE INSTALLED INCREMENTALLY AS CONSTRUCTION PROGRESSES, PER THE SEQUENCE OF CONSTRUCTION.

COIR FIBER MATTING - TYPICAL SLOPE CROSS SECTION

NOT TO SCALE

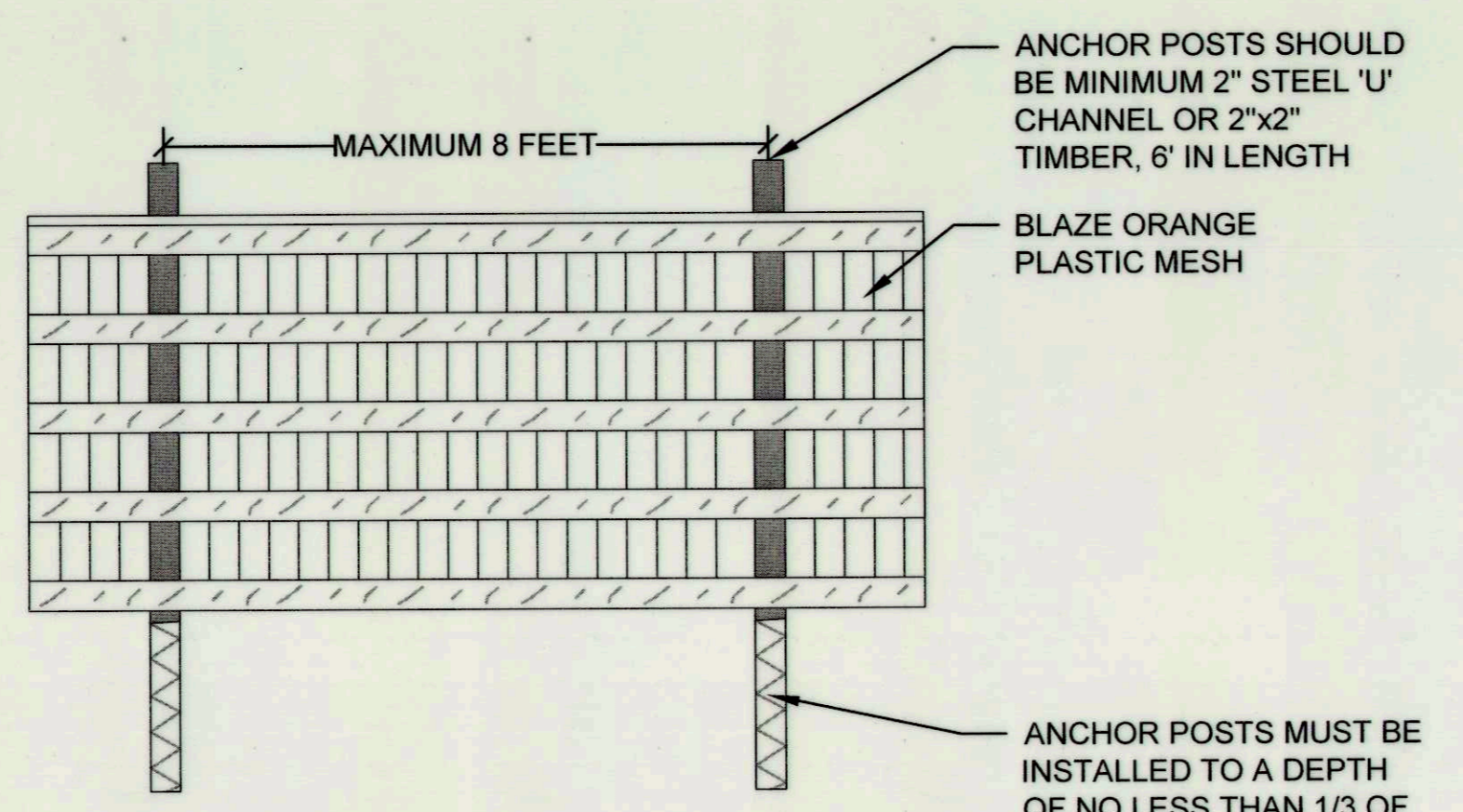

- NOTES:
1. PROTECTION AREA WILL BE SET AS PART OF THE REVIEW PROCESS.
 2. BOUNDARIES OF PROTECTION AREA SHOULD BE STAKED AND FLAGGED PRIOR TO INSTALLING DEVICES.
 3. DEVICE SHOULD BE MAINTAINED THROUGHOUT CONSTRUCTION.

BLAZE ORANGE PLASTIC FENCE

NOT TO SCALE

CLIENT
 HOWARD COUNTY
 STORMWATER MANAGEMENT DIVISION
 6751 GATEWAY DRIVE, SUITE 514
 COLUMBIA, MD 21046
 PHONE: (410) 313-6413

DATE	ISSUES / REVISIONS

The Stables Building 2081 Clipper Park Road
 Baltimore, MD 21211 / ph: 410.554.0156
 fx: 410.554.0168 / www.biohabitats.com
 Restore the Earth & Inspire Ecological Stewardship

CHURCHILL WAY OUTFALL STABILIZATION

SITE ADDRESS: 10430 CHURCHILL WAY, LAUREL, MD
 ZONING: R-20 TAX MAP GRID/PARCEL: 0042/0018/0081
 ELECTION DISTRICT: 06 HOWARD COUNTY OPEN SPACE

EROSION AND SEDIMENT CONTROL DETAILS

PROJECT NO.: 13005.47 SCALE: NTS
 SEAL: BY: KT CHECK: MDT/BVL
 DWG. NO.:

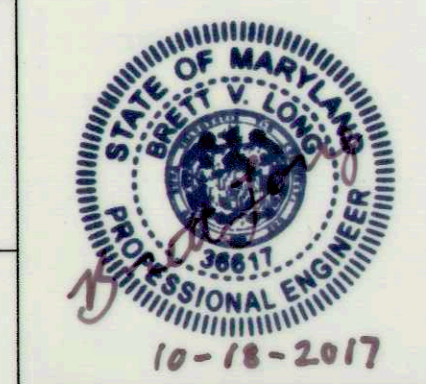

6 OF 9

This development plan is approved for soil erosion and sediment control by the HOWARD SOIL CONSERVATION DISTRICT

Howard SCD Date: 10/29/17

DEPARTMENT OF PUBLIC WORKS, HOWARD COUNTY, MD

Mark DeLuca Date: 10/19/17
 CHIEF, BUREAU OF ENVIRONMENTAL SERVICES

MGWC 1.2: PUMP-AROUND PRACTICE

Temporary measure for dewatering in-channel construction sites

DESCRIPTION

The work should consist of installing a temporary pump around and supporting measures to divert flow around in-stream construction sites.

IMPLEMENTATION SEQUENCE

Sediment control measures, pump-around practices, and associated channel and bank construction should be completed in the following sequence (refer to Detail 1.2):

- Construction activities including the installation of erosion and sediment control measures should not begin until all necessary easements and/or right-of-ways have been acquired. All existing utilities should be marked in the field prior to construction. The contractor is responsible for any damage to existing utilities that may result from construction and should repair the damage at his/her own expense to the county's or utility company's satisfaction.
- The contractor should notify the Maryland Department of the Environment or WMA sediment control inspector at least 5 days before beginning construction. Additionally, the contractor should inform the local environmental protection and resource management inspection and enforcement division and the provider of local utilities a minimum of 48 hours before starting construction.
- The contractor should conduct a pre-construction meeting on site with the WMA sediment control inspector, the county project manager, and the engineer to review limits of disturbance, erosion and sediment control requirements, and the sequence of construction. The contractor should stake out all limits of disturbance prior to the pre-construction meeting so they may be reviewed. The participants will also designate the contractor's staging areas and flag all trees within the limit of disturbance which will be removed for construction access. Trees should not be removed within the limit of disturbance without approval from the WMA or local authority.
- Construction should not begin until all sediment and erosion control measures have been installed and approved by the engineer and the sediment control inspector. The contractor should stay within the limits of the disturbance as shown on the plans and minimize disturbance within the work area whenever possible.
- Upon installation of all sediment control measures and approval by the sediment control inspector and the local environmental protection and resource management inspection and enforcement division, the contractor should begin work at the upstream section and proceed downstream beginning with the establishment of stabilized construction entrances. In some cases, work may begin downstream if appropriate. The sequence of construction must be followed unless the contractor gets written approval for deviations from the WMA or local authority. The contractor should only begin work in an area which can be completed by the end of the day including grading adjacent to the channel. At the end of each work day, the work area must be stabilized and the pump around removed from the channel. Work should not be conducted in the channel during rain events.
- Sandbag dikes should be situated at the upstream and downstream ends of the work area as shown on the plans, and stream flow should be pumped around the work area. The pump should discharge onto a stable velocity dissipater made of riprap or sandbags.

TEMPORARY INSTREAM CONSTRUCTION MEASURES

MARYLAND DEPARTMENT OF THE ENVIRONMENT
WATERWAY CONSTRUCTION GUIDELINES
REVISED NOVEMBER 2000

PAGE 1.2 - 1

MGWC 1.2: PUMP-AROUND PRACTICE

- Water from the work area should be pumped to a sediment filtering measure such as a dewatering basin, sediment bag, or other approved source. The measure should be located such that the water drains back into the channel below the downstream sandbag dike.
- Traversing a channel reach with equipment within the work area where no work is proposed should be avoided. If equipment has to traverse such a reach for access to another area, then timber mats or similar measures should be used to minimize disturbance to the channel. Temporary stream crossings should be used only when necessary and only where noted on the plans or specified. (See Section 4, Stream Crossings, Maryland Guidelines to Waterway Construction).
- All stream restoration measures should be installed as indicated by the plans and all banks graded in accordance with the grading plans and typical cross-sections. All grading must be stabilized at the end of each day with seed and mulch or seed and matting as specified on the plans.
- After an area is completed and stabilized, the clean water dike should be removed. After the first sediment flush, a new clean water dike should be established upstream from the old sediment dike. Finally, upon establishment of a new sediment dike below the old one, the old sediment dike should be removed.
- A pump around must be installed on any tributary or storm drain outfall which contributes baseflow to the work area. This should be accomplished by locating a sandbag dike at the downstream end of the tributary or storm drain outfall and pumping the stream flow around the work area. This water should discharge onto the same velocity dissipater used for the main stem pump around.
- If a tributary is to be restored, construction should take place on the tributary before work on the main stem reaches the tributary confluence. Construction in the tributary, including pump around practices, should follow the same sequence as for the main stem of the river or stream. When construction on the tributary is completed, work on the main stem should resume. Water from the tributary should continue to be pumped around the work area in the main stem.
- The contractor is responsible for providing access to and maintaining all erosion and sediment control devices until the sediment control inspector approves their removal.
- After construction, all disturbed areas should be regraded and revegetated as per the planting plan.

TEMPORARY INSTREAM CONSTRUCTION MEASURES

MARYLAND DEPARTMENT OF THE ENVIRONMENT
WATERWAY CONSTRUCTION GUIDELINES
REVISED NOVEMBER 2000

PAGE 1.2 - 2

**Maryland's Guidelines To Waterway Construction
DETAIL 1.2: PUMP-AROUND PRACTICE**

PLAN VIEW

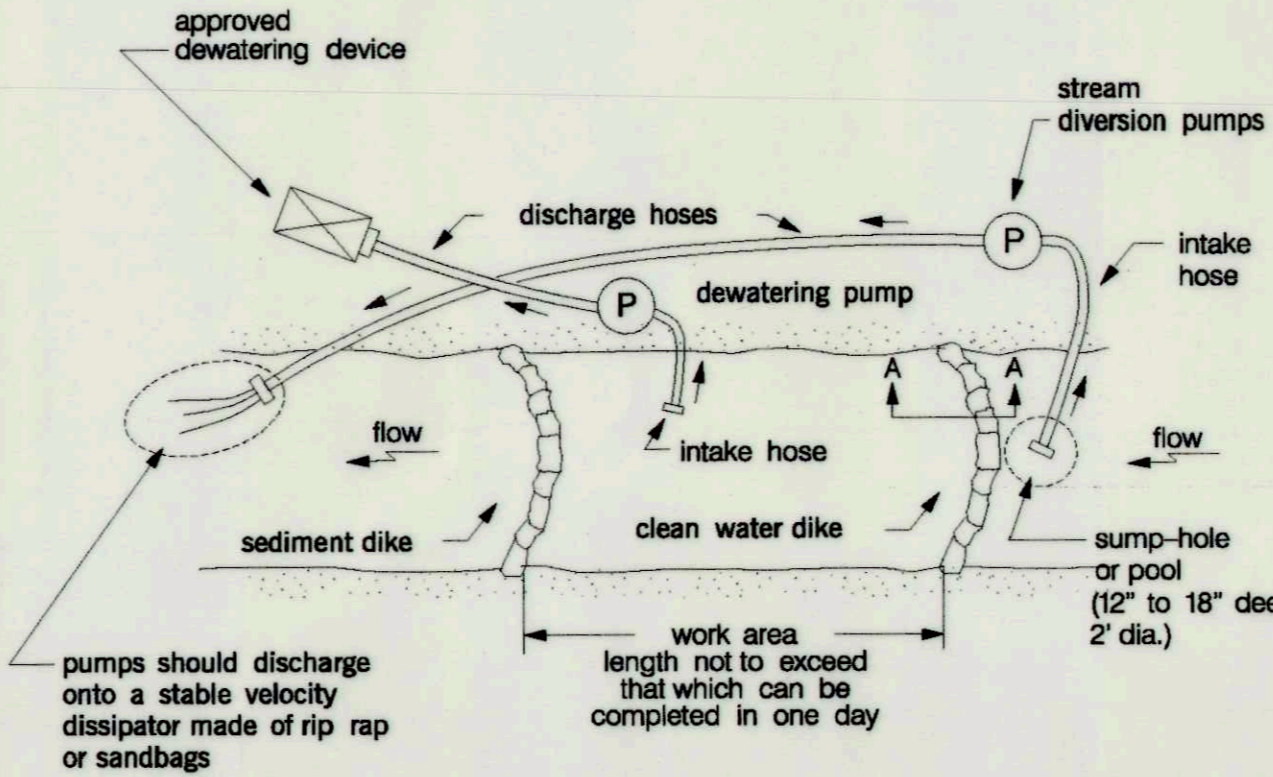

SECTION A-A

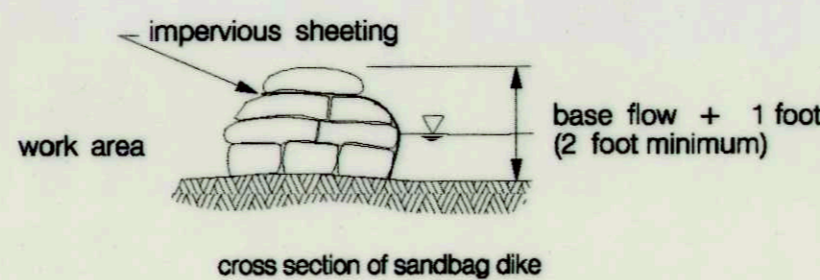

TEMPORARY INSTREAM CONSTRUCTION MEASURES
REVISED NOVEMBER 2000
PAGE 1.2 - 3
MARYLAND DEPARTMENT OF THE ENVIRONMENT
WATER MANAGEMENT ADMINISTRATION

**DETAIL B-4-6-B
TEMPORARY SOIL STABILIZATION MATTING
SLOPE APPLICATION**

STANDARD SYMBOL
TSSMS - * 1.0 lb/ft²
(* INCLUDE SHEAR STRESS)

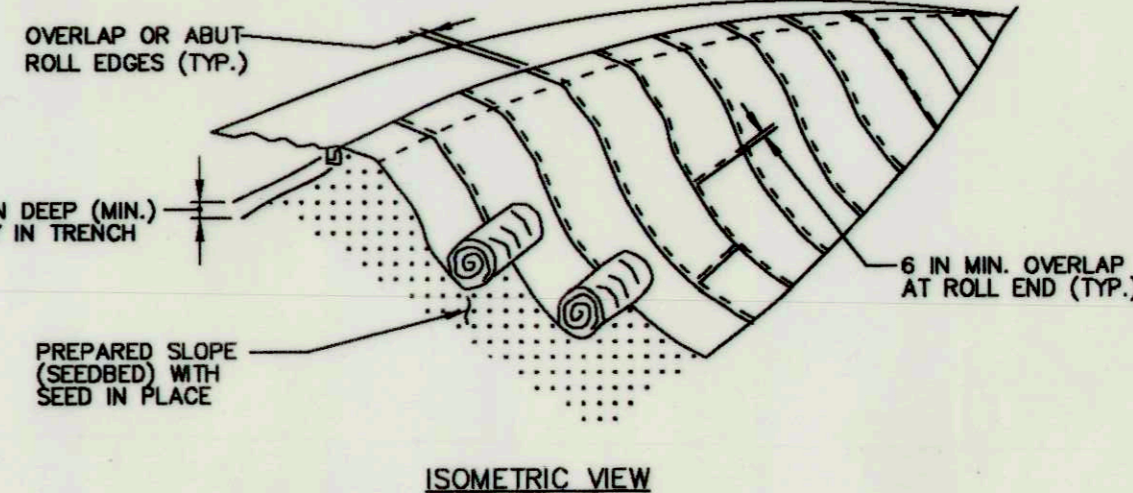

CONSTRUCTION SPECIFICATIONS

- USE MATTING THAT HAS A DESIGN VALUE FOR SHEAR STRESS EQUAL TO OR HIGHER THAN THE SHEAR STRESS DESIGNATED ON APPROVED PLANS.
- USE TEMPORARY SOIL STABILIZATION MATTING MADE OF DEGRADABLE (LASTS 6 MONTHS MINIMUM) NATURAL OR MAN-MADE FIBERS (MOSTLY ORGANIC). MAT MUST HAVE UNIFORM THICKNESS AND DISTRIBUTION OF FIBERS THROUGHOUT AND BE SOLDER RESISTANT. CHEMICALS USED IN THE MAT MUST BE NON-LEACHING AND NON-TOXIC TO VEGETATION AND SEED GERMINATION AND NON-INJURIOUS TO THE SKIN. IF PRESENT, NETTING MUST BE EXTRUDED PLASTIC WITH A MAXIMUM MESH OPENING OF 2x2 INCHES AND SUFFICIENTLY BONDED OR SEWN ON 2 INCH CENTERS ALONG LONGITUDINAL AXIS OF THE MATERIAL TO PREVENT SEPARATION OF THE NET FROM THE PARENT MATERIAL.
- SECURE MATTING USING STEEL STAPLES, WOOD STAKES, OR BIODEGRADABLE EQUIVALENT. STAPLES MUST BE "U" OR "T" SHAPED STEEL WIRE HAVING A MINIMUM GAUGE OF NO. 11 AND NO. 8 RESPECTIVELY. "U" SHAPED STAPLES MUST AVERAGE 1 TO 1 1/2 INCHES WIDE AND BE A MINIMUM OF 6 INCHES LONG. "T" SHAPED STAPLES MUST HAVE A MINIMUM 8 INCH MAIN LEG, A MINIMUM 1 INCH SECONDARY LEG, AND A MINIMUM 4 INCH HEAD. WOOD STAKES MUST BE ROUGH-SAWN HARDWOOD, 12 TO 24 INCHES IN LENGTH, 1x3 INCH IN CROSS SECTION, AND WEDGE SHAPED AT THE BOTTOM.
- PERFORM FINAL GRADING, TOPSOIL APPLICATION, SEEDBED PREPARATION, AND PERMANENT SEEDING IN ACCORDANCE WITH SPECIFICATIONS. PLACE MATTING WITHIN 48 HOURS OF COMPLETING SEEDING OPERATIONS UNLESS END OF WORKDAY STABILIZATION IS SPECIFIED ON THE APPROVED EROSION & SEDIMENT CONTROL PLAN.
- UNROLL MATTING DOWNSLOPE. LAY MAT SMOOTHLY AND FIRMLY UPON THE SEEDED SURFACE. AVOID STRETCHING THE MATTING.
- OVERLAP OR ABUT ROLL EDGES PER MANUFACTURER RECOMMENDATIONS. OVERLAP ROLL ENDS BY 6 INCHES (MINIMUM), WITH THE UPSLOPE MAT OVERLAPPING ON TOP OF THE DOWNSLOPE MAT.
- KEY IN THE UPSLOPE END OF MAT 6 INCHES (MINIMUM) BY DIGGING A TRENCH, PLACING THE MATTING ROLL END IN THE TRENCH, STAPLING THE MAT IN PLACE, REPLACING THE EXCAVATED MATERIAL, AND TAMPING TO SECURE THE MAT END IN THE KEY.
- STAPLE/STAKE MAT IN A STAGGERED PATTERN ON 4 FOOT (MAXIMUM) CENTERS THROUGHOUT AND 2 FOOT (MAXIMUM) CENTERS ALONG SEAMS, JOINTS, AND ROLL ENDS.
- ESTABLISH AND MAINTAIN VEGETATION SO THAT REQUIREMENTS FOR ADEQUATE VEGETATIVE ESTABLISHMENT ARE CONTINUOUSLY MET IN ACCORDANCE WITH SECTION B-4 VEGETATIVE STABILIZATION.

MARYLAND STANDARDS AND SPECIFICATIONS FOR SOIL EROSION AND SEDIMENT CONTROL
U.S. DEPARTMENT OF AGRICULTURE
NATURAL RESOURCES CONSERVATION SERVICE
2011
MARYLAND DEPARTMENT OF ENVIRONMENT
WATER MANAGEMENT ADMINISTRATION

DETAIL B-1 STABILIZED CONSTRUCTION ENTRANCE

STANDARD SYMBOL
SCE

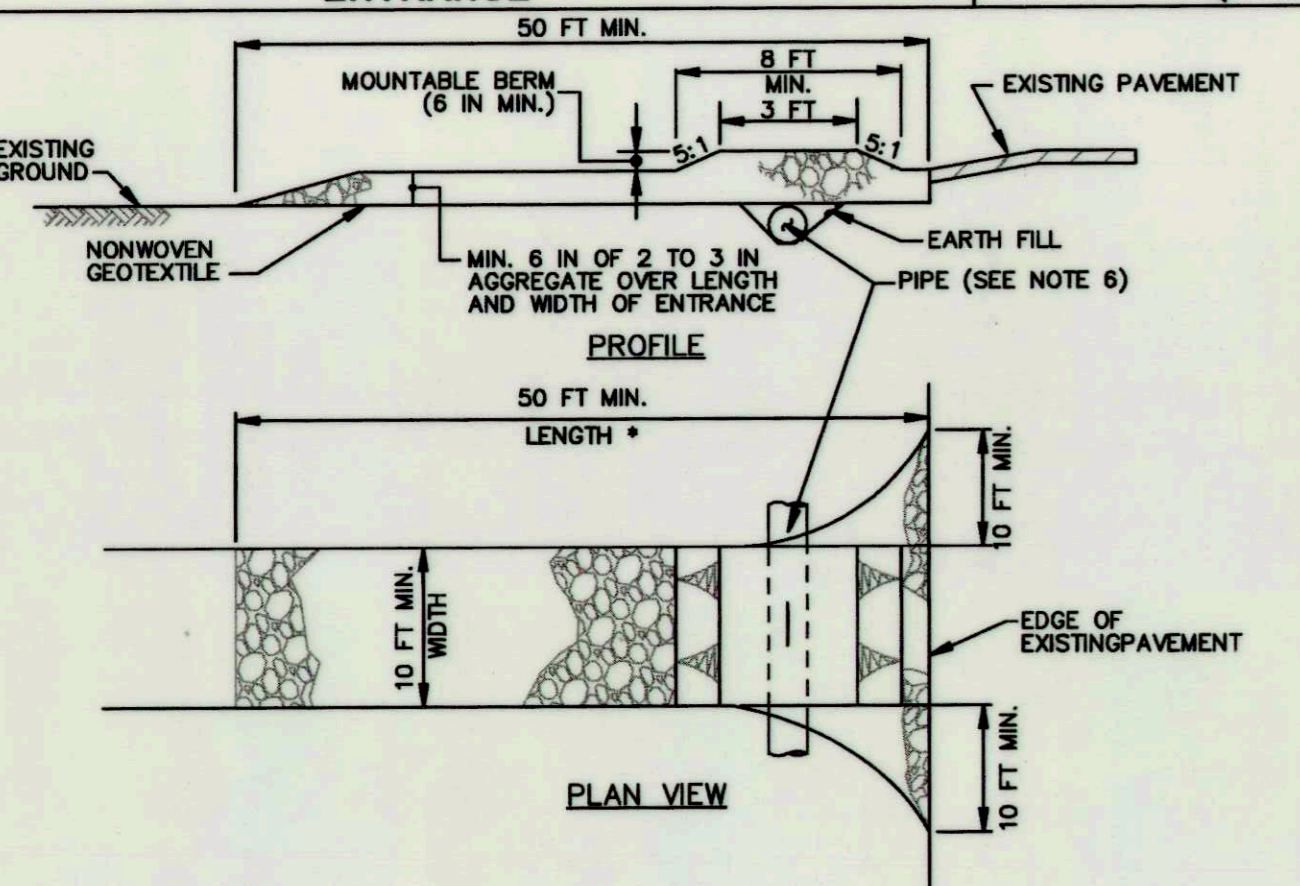

CONSTRUCTION SPECIFICATIONS

- PLACE STABILIZED CONSTRUCTION ENTRANCE IN ACCORDANCE WITH THE APPROVED PLAN. VEHICLES MUST TRAVEL OVER THE ENTIRE LENGTH OF THE SCE. USE MINIMUM LENGTH OF 50 FEET (*30 FEET FOR SINGLE RESIDENCE LOT). USE MINIMUM WIDTH OF 10 FEET. FLARE SCE 10 FEET MINIMUM AT THE EXISTING ROAD TO PROVIDE A TURNING RADIUS.
- PIPE ALL SURFACE WATER FLOWING TO OR DIVERTED TOWARD THE SCE UNDER THE ENTRANCE. MAINTAINING POSITIVE DRAINAGE. PROTECT PIPE INSTALLED THROUGH THE SCE WITH A MOUNTABLE BERM WITH 5:1 SLOPES AND A MINIMUM OF 12 INCHES OF STONE OVER THE PIPE. PROVIDE PIPE AS SPECIFIED ON APPROVED PLAN. WHEN THE SCE IS LOCATED AT A HIGH SPOT AND HAS NO DRAINAGE TO CONVEY, A PIPE IS NOT NECESSARY. A MOUNTABLE BERM IS REQUIRED WHEN SCE IS NOT LOCATED AT A HIGH SPOT.
- PREPARE SUBGRADE AND PLACE NONWOVEN GEOTEXTILE, AS SPECIFIED IN SECTION H-1 MATERIALS.
- PLACE CRUSHED AGGREGATE (2 TO 3 INCHES IN SIZE) OR EQUIVALENT RECYCLED CONCRETE (WITHOUT REBAR) AT LEAST 6 INCHES DEEP OVER THE LENGTH AND WIDTH OF THE SCE.
- MAINTAIN ENTRANCE IN A CONDITION THAT MINIMIZES TRACKING OF SEDIMENT. ADD STONE OR MAKE OTHER REPAIRS AS CONDITIONS DEMAND TO MAINTAIN CLEAN SURFACE, MOUNTABLE BERM, AND SPECIFIED DIMENSIONS. IMMEDIATELY REMOVE STONE AND/OR SEDIMENT SPILLED, DROPPED, OR TRACKED ONTO ADJACENT ROADWAY BY VACUUMING, SCRAPPING, AND/OR SWEEPING. WASHING ROADWAY TO REMOVE MUD TRACKED ONTO PAVEMENT IS NOT ACCEPTABLE UNLESS WASH WATER IS DIRECTED TO AN APPROVED SEDIMENT CONTROL PRACTICE.

MARYLAND STANDARDS AND SPECIFICATIONS FOR SOIL EROSION AND SEDIMENT CONTROL
U.S. DEPARTMENT OF AGRICULTURE
NATURAL RESOURCES CONSERVATION SERVICE
2011
MARYLAND DEPARTMENT OF ENVIRONMENT
WATER MANAGEMENT ADMINISTRATION

DETAIL E-3 SUPER SILT FENCE

STANDARD SYMBOL
SSF

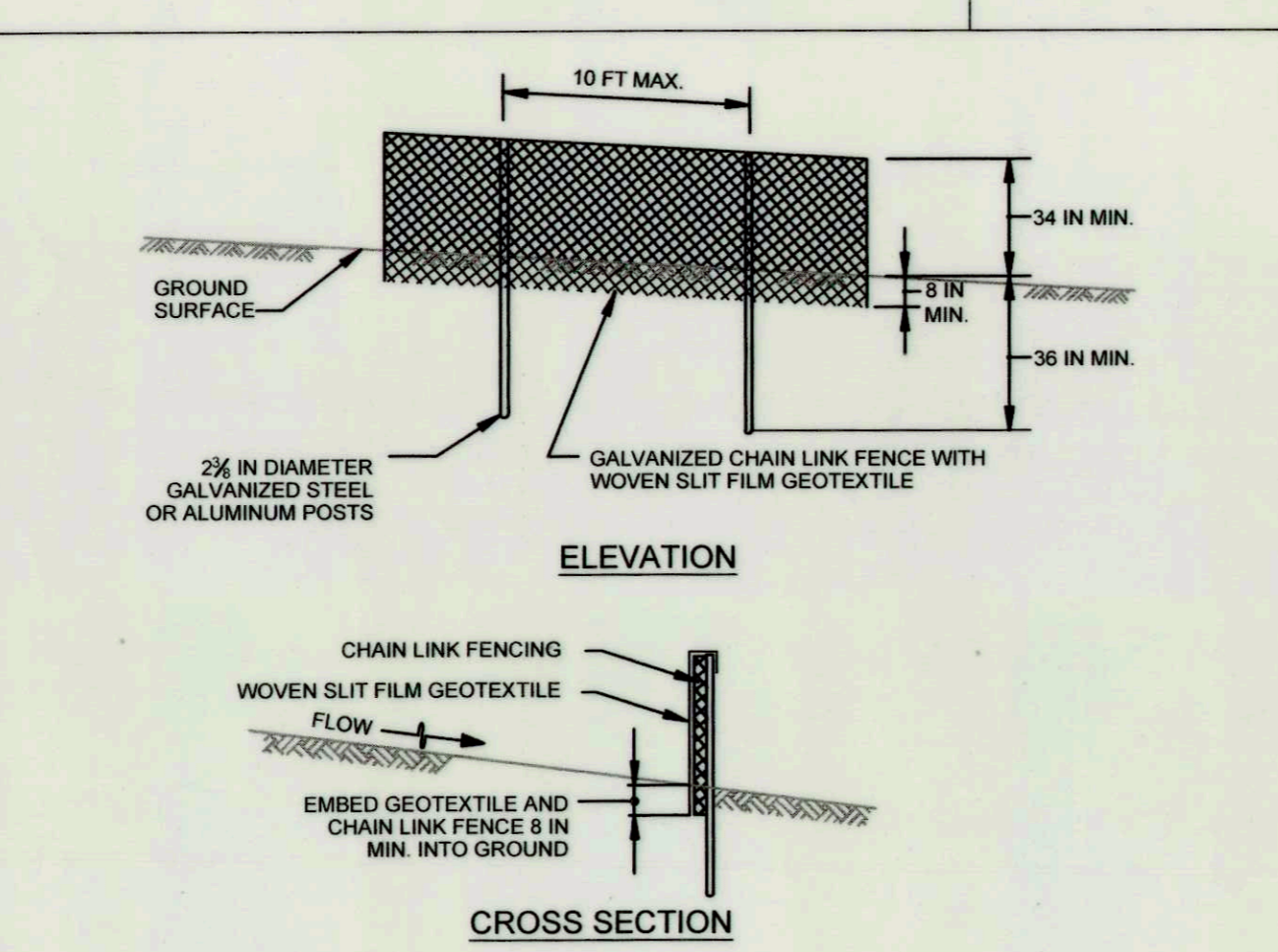

CONSTRUCTION SPECIFICATIONS

- INSTALL 2 1/2 INCH DIAMETER GALVANIZED STEEL POSTS OF 0.095 INCH WALL THICKNESS AND SIX FOOT LENGTH SPACED NO FURTHER THAN 10 FEET APART. DRIVE THE POSTS A MINIMUM OF 36 INCHES INTO THE GROUND.
- FASTEN 9 GAUGE OR HEAVIER GALVANIZED CHAIN LINK FENCE (2 1/2 INCH MAXIMUM OPENING) 42 INCHES IN HEIGHT SECURELY TO THE FENCE POSTS WITH WIRE TIES OR HUG RINGS.
- FASTEN WOVEN SLIT FILM GEOTEXTILE AS SPECIFIED IN SECTION H-1 MATERIALS, SECURELY TO THE UPSLOPE SIDE OF CHAIN LINK FENCE WITH TIES SPACED EVERY 24 INCHES AT THE TOP AND MID SECTION. EMBED GEOTEXTILE AND CHAIN LINK FENCE A MINIMUM OF 8 INCHES INTO THE GROUND.
- WHERE ENDS OF THE GEOTEXTILE COME TOGETHER, THE ENDS SHALL BE OVERLAPPED BY 6 INCHES, FOLDED, AND STAPLED TO PREVENT SEDIMENT BY PASS.
- EXTEND BOTH ENDS OF THE SUPER SILT FENCE A MINIMUM OF FIVE HORIZONTAL FEET UPSLOPE AT 45 DEGREES TO THE MAIN FENCE ALIGNMENT TO PREVENT RUNOFF FROM GOING AROUND THE ENDS OF THE SUPER SILT FENCE.
- PROVIDE MANUFACTURER CERTIFICATION TO THE INSPECTION/ENFORCEMENT AUTHORITY SHOWING THAT GEOTEXTILE USED MEETS THE REQUIREMENTS IN SECTION H-1 MATERIALS.
- REMOVE ACCUMULATED SEDIMENT AND DEBRIS WHEN BULGES DEVELOP IN FENCE OR WHEN SEDIMENT REACHES 25% OF FENCE HEIGHT. REPLACE GEOTEXTILE IF TORN, IF UNDERMINING OCCURS, REINSTALL CHAIN LINK FENCING AND GEOTEXTILE.

MARYLAND STANDARDS AND SPECIFICATIONS FOR SOIL EROSION AND SEDIMENT CONTROL
U.S. DEPARTMENT OF AGRICULTURE
NATURAL RESOURCES CONSERVATION SERVICE
2011
MARYLAND DEPARTMENT OF ENVIRONMENT
WATER MANAGEMENT ADMINISTRATION

DETAIL E-6 FILTER LOG

STANDARD SYMBOL
FL-18
DESIGNATION FL-18 REFERS TO 18 INCH DIAMETER FILTER LOG.

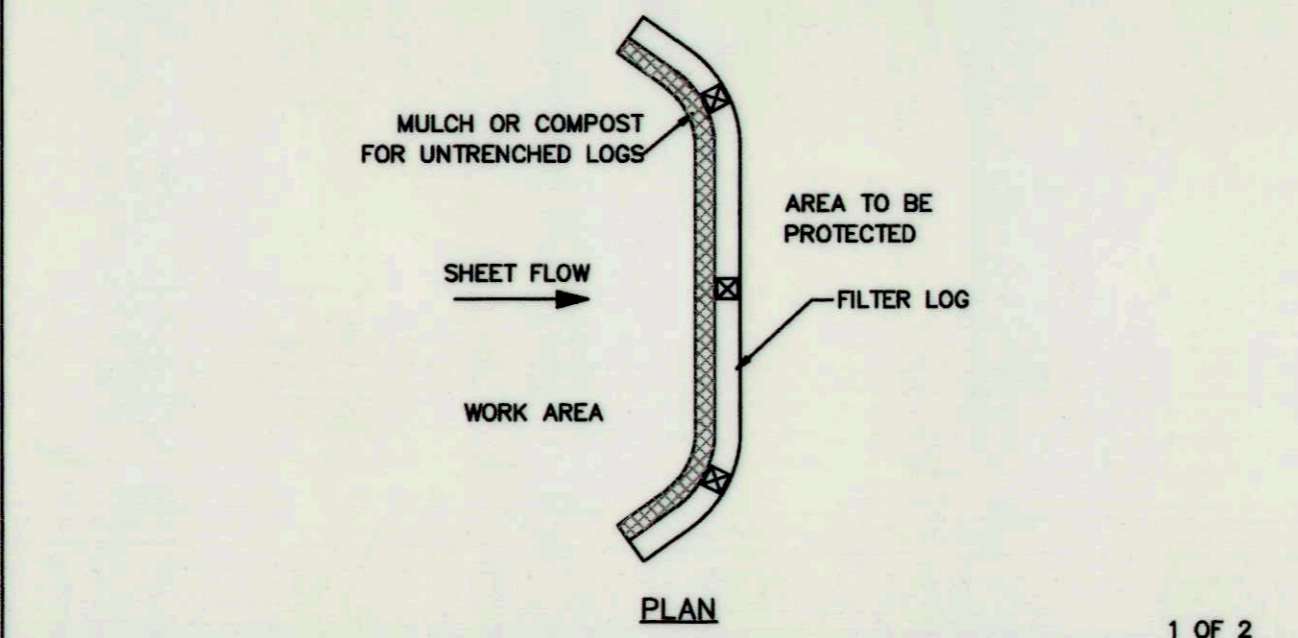
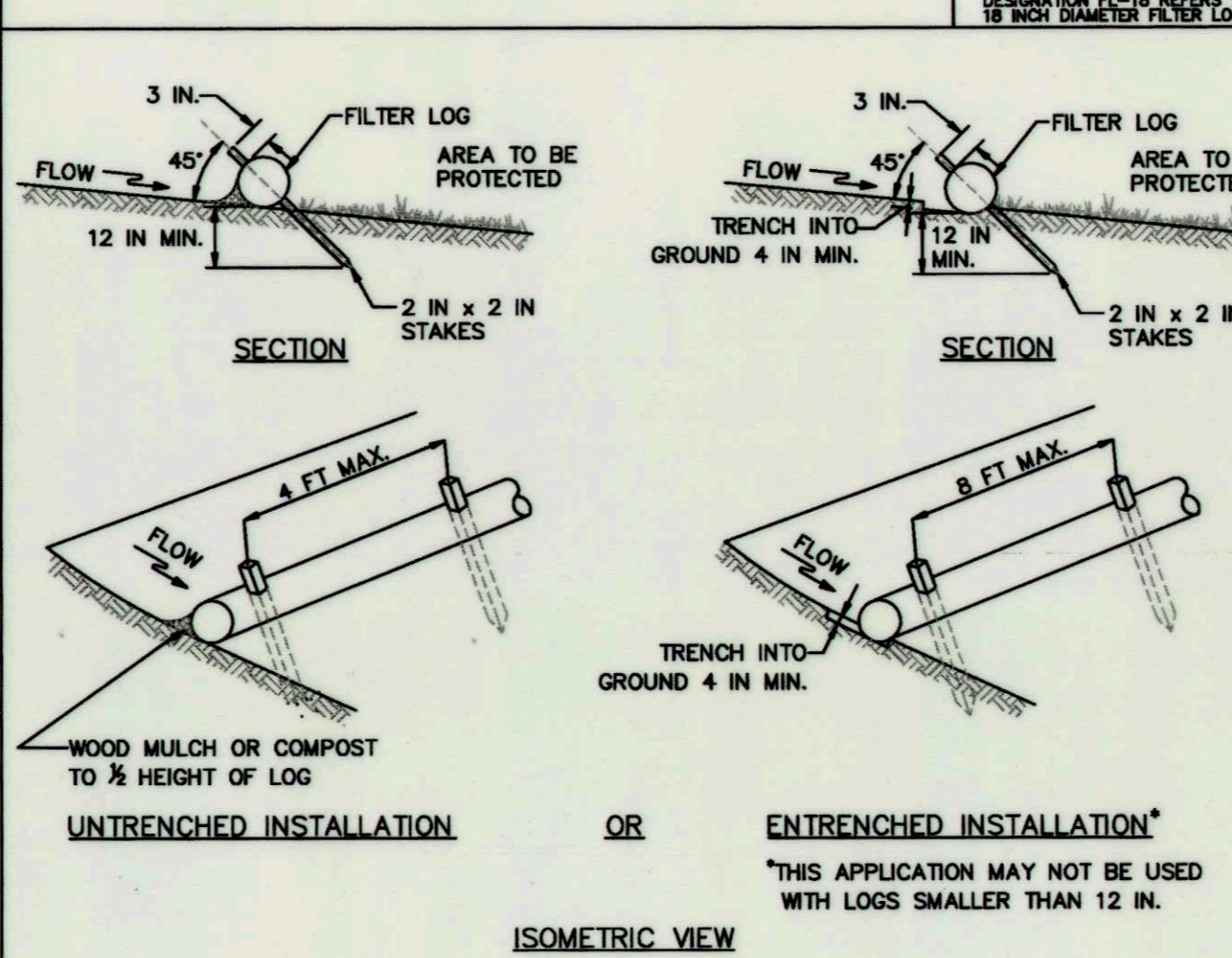

MARYLAND STANDARDS AND SPECIFICATIONS FOR SOIL EROSION AND SEDIMENT CONTROL
U.S. DEPARTMENT OF AGRICULTURE
NATURAL RESOURCES CONSERVATION SERVICE
2011
MARYLAND DEPARTMENT OF ENVIRONMENT
WATER MANAGEMENT ADMINISTRATION

DETAIL E-6 FILTER LOG

STANDARD SYMBOL
FL-18
DESIGNATION FL-18 REFERS TO 18 INCH DIAMETER FILTER LOG.

CONSTRUCTION SPECIFICATIONS

- PRIOR TO INSTALLATION, CLEAR ALL OBSTRUCTIONS INCLUDING ROCKS, CLODS, AND DEBRIS GREATER THAN ONE INCH THAT MAY INTERFERE WITH PROPER FUNCTION OF FILTER LOG.
- FILL LOG NETTING UNIFORMLY WITH COMPOST (IN ACCORDANCE WITH SECTION H-1 MATERIALS), OR OTHER APPROVED BIODEGRADABLE MATERIAL TO DESIRED LENGTH SUCH THAT LOGS DO NOT DEFORM.
- INSTALL FILTER LOGS PERPENDICULAR TO THE FLOW DIRECTION AND PARALLEL TO THE SLOPE WITH THE BEGINNING AND END OF THE INSTALLATION POINTING SLIGHTLY UP THE SLOPE CREATING A "J" SHAPE AT EACH END TO PREVENT BYPASS.
- FOR UNTRENCHED INSTALLATION BLOW OR HAND PLACE MULCH OR COMPOST ON UPHILL SIDE OF THE SLOPE ALONG LOG.
- STAKE FILTER LOG EVERY 4 FEET OR CLOSER ALONG ENTIRE LENGTH OF LOG OR TRENCH LOG INTO GROUND A MINIMUM OF 4 INCHES AND STAKE LOG EVERY 8 FEET OR CLOSER.
- USE STAKES WITH A MINIMUM NOMINAL CROSS SECTION OF 2X2 INCH AND OF SUFFICIENT LENGTH TO ATTAIN A MINIMUM OF 12 INCHES INTO THE GROUND AND 3 INCHES PROTRUDING ABOVE LOG.
- WHEN MORE THAN ONE LOG IS NEEDED, OVERLAP ENDS 12 INCHES MINIMUM AND STAKE.
- REMOVE SEDIMENT WHEN IT HAS ACCUMULATED TO A DEPTH OF 1/2 THE EXPOSED HEIGHT OF LOG AND REPLACE MULCH. REPLACE FILTER LOG IF TORN, REINSTALL FILTER LOG IF UNDERMINING OR DISLODGING OCCURS. REPLACE CLOGGED FILTER LOGS. FOR PERMANENT APPLICATIONS, ESTABLISH AND CONTINUOUSLY MEET REQUIREMENTS FOR ADEQUATE VEGETATIVE ESTABLISHMENT IN ACCORDANCE WITH SECTION B-4 VEGETATIVE STABILIZATION.

MARYLAND STANDARDS AND SPECIFICATIONS FOR SOIL EROSION AND SEDIMENT CONTROL
U.S. DEPARTMENT OF AGRICULTURE
NATURAL RESOURCES CONSERVATION SERVICE
2011
MARYLAND DEPARTMENT OF ENVIRONMENT
WATER MANAGEMENT ADMINISTRATION

CLIENT
HOWARD COUNTY
STORMWATER MANAGEMENT DIVISION
6751 GATEWAY DRIVE, SUITE 514
COLUMBIA, MD 21046
PHONE: (410) 313-6413

DATE ISSUES / REVISIONS

The Stables Building 2081 Clipper Park Road
Baltimore, MD 21211 / ph: 410.554.0156
fx: 410.554.0168 / www.biohabitats.com
Restore the Earth & Inspire Ecological Stewardship

**CHURCHILL WAY
OUTFALL
STABILIZATION**

SITE ADDRESS: 10430 CHURCHILL WAY, LAUREL, MD
ZONING: R-20
ELECTION DISTRICT: 06
TAX MAP/GRID/PARCEL: 00420019/00981
HOWARD COUNTY OPEN SPACE

**EROSION AND
SEDIMENT
CONTROL DETAILS**

TITLE: EROSION AND SEDIMENT CONTROL DETAILS
PROJECT NO.: 13005.47
SCALE: NTS
BY: KT
CHECK: MDT/BVL
DWG NO.: 7 OF 9
DATE: 10/29/12
DATE: 10/19/12

B-4.5 STANDARDS AND SPECIFICATIONS

FOR

PERMANENT STABILIZATION

Definition

To stabilize disturbed soils with permanent vegetation.

Purpose

To use long-lived perennial grasses and legumes to establish permanent ground cover on disturbed soils.

Conditions Where Practice Applies

Exposed soils where ground cover is needed for 6 months or more.

Criteria

- A. Seed Mixtures
 - 1. General Use
 - a. Select one or more of the species or mixtures listed in Table B.3 for the appropriate Plant Hardiness Zone (from Figure B.3) and based on the site condition or purpose found on Table B.2. Enter selected mixture(s), application rates, and seeding dates in the Permanent Seeding Summary. The Summary is to be placed on the plan.
 - b. Additional planting specifications for exceptional sites such as shorelines, stream banks, or dunes or for special purposes such as wildlife or aesthetic treatment may be found in USDA-NRCS Technical Field Office Guide, Section 342 - Critical Area Planting.
 - c. For sites having disturbed area over 5 acres, use and show the rates recommended by the soil testing agency.
 - d. For areas receiving low maintenance, apply urea form fertilizer (46-0-0) at 3 1/2 pounds per 1000 square feet (150 pounds per acre) at the time of seeding in addition to the soil amendments shown in the Permanent Seeding Summary.
 - 2. Turfgrass Mixtures
 - a. Areas where turfgrass may be desired include lawns, parks, playgrounds, and commercial sites which will receive a medium to high level of maintenance.
 - b. Select one or more of the species or mixtures listed below based on the site conditions or purpose. Enter selected mixture(s), application rates, and seeding dates in the Permanent Seeding Summary. The Summary is to be placed on the plan.
 - i. Kentucky Bluegrass/ Full Sun Mixture: For use in areas that receive intensive management. Irrigation required in the areas of central Maryland and Eastern Shore. Recommended Certified Kentucky Bluegrass Cultivars Seeding Rate: 1.5 to 2.0 pounds per 1000 square feet. Choose a minimum of three Kentucky bluegrass cultivars with each ranging from 10 to 35 percent of the total mixture by weight.
 - ii. Kentucky Bluegrass/Perennial Rye: Full Sun Mixture: For use in full sun areas where rapid establishment is necessary and when turf will receive medium to intensive management. Certified Perennial Ryegrass Cultivars/Certified Kentucky Bluegrass Seeding Rate: 2 pounds mixture per 1000 square feet. Choose a minimum of three Kentucky bluegrass cultivars with each ranging from 10 to 35 percent of the total mixture by weight.
 - iii. Tall Fescue/Kentucky Bluegrass: Full Sun Mixture: For use in drought prone areas and/or for areas receiving low to medium management in full sun to medium shade. Recommended mixture includes; Certified Tall Fescue Cultivars 95 to 100 percent, Certified Kentucky Bluegrass Cultivars 0 to 5 percent. Seeding Rate: 5 to 8 pounds per 1000 square feet. One or more cultivars may be blended.
 - iv. Kentucky Bluegrass/Fine Fescue: Shade Mixture: For use in areas with shade in Bluegrass lawns. For establishment in high quality, intensively managed turf area. Mixture includes; Certified Kentucky Bluegrass Cultivars 30 to 40 percent and Certified Fine Fescue and 60 to 70 percent. Seeding Rate: 1 1/2 to 3 pounds per 1000 square feet.

Notes:
Select turfgrass varieties from those listed in the most current University of Maryland Publication, Agronomy Memo #77, "Turfgrass Cultivar Recommendations for Maryland"

Choose certified material. Certified material is the best guarantee of cultivar purity. The certification program of the Maryland Department of Agriculture, Turf and Seed Section, provides a reliable means of consumer protection and assures a pure genetic line

- c. Ideal Times of Seeding for Turf Grass Mixtures
 - Western MD: March 15 to June 1, August 1 to October 1 (Hardiness Zones: 5b, 6a)
 - Central MD: March 1 to May 15, August 15 to October 15 (Hardiness Zone: 6b)
 - Southern MD, Eastern Shore: March 1 to May 15, August 15 to October 15 (Hardiness Zones: 7a, 7b)

- d. Till areas to receive seed by disking or other approved methods to a depth of 2 to 4 inches, level and rake the areas to prepare a proper seedbed. Remove stones and debris over 1 1/2 inches in diameter. The resulting seedbed must be in such condition that future mowing of grasses will pose no difficulty.
- e. If soil moisture is deficient, supply new seedlings with adequate water for plant growth (1/2 to 1 inch every 3 to 4 days depending on soil texture) until they are firmly established. This is especially true when seedlings are made late in the planting season, in abnormally dry or hot seasons, or on adverse sites.

Permanent Seeding Summary

Hardiness Zone (from Figure B.3): <u>6b</u>					Fertilizer Rate (10-20-20)			Lime Rate
Seed Mixture (from Table B.3): <u>4</u>					N	P ₂ O ₅	K ₂ O	
No.	Species	Application Rate (lb/ac)	Seeding Dates	Seeding Depths				
4	DEERTONGUE	15	3/1 - 6/15	1/4 - 1/2 in	45 pounds per acre	90 lb/ac (2 lb/1000 sf)	90 lb/ac (2 lb/1000 sf)	2 tons/ac (90 lb/1000 sf)
	CREEPING RED FESCUE	20	3/1 - 5/15 8/1 - 10/15	1/4 - 1/2 in	(1.0 lb/1000 sf)	1000 sf)	1000 sf)	1000 sf)
	VIRGINIA WILD RYE	5	3/1 - 5/15 8/1 - 10/15	1/4 - 1/2 in				

- B. Sod: To provide quick cover on disturbed areas (2:1 grade or flatter).
 - 1. General Specifications
 - a. Class of turfgrass sod must be Maryland State Certified. Sod labels must be made available to the job foreman and inspector.
 - b. Sod must be machine cut at a uniform soil thickness of 3/4 inch, plus or minus 1/8 inch, at the time of cutting. Measurement for thickness must exclude top growth and thatch. Broken pads and torn or uneven ends will not be acceptable.
 - c. Standard size sections of sod must be strong enough to support their own weight and retain their size and shape when suspended vertically with a firm grasp on the upper 10 percent of the section.
 - d. Sod must not be harvested or transplanted when moisture content (excessively dry or wet) may adversely affect its survival.

- e. Sod must be harvested, delivered, and installed within a period of 36 hours. Sod not transplanted within this period must be approved by an agronomist or soil scientist prior to its installation.
- 2. Sod Installation
 - a. During periods of excessively high temperature or in areas having dry subsoil, lightly irrigate the subsoil immediately prior to laying the sod.
 - b. Lay the first row of sod in a straight line with subsequent rows placed parallel to it and tightly wedged against each other. Stagger lateral joints to promote more uniform growth and strength. Ensure that sod is not stretched or overlapped and that all joints are butted tight in order to prevent voids which would cause air drying of the roots.
 - c. Wherever possible, lay sod with the long edges parallel to the contour and with staggering joints. Roll and tamp, peg or otherwise secure the sod to prevent slippage on slopes. Ensure solid contact exists between sod roots and the underlying soil surface.
 - d. Water the sod immediately following rolling and tamping until the underside of the new sod pad and soil surface below the sod are thoroughly wet. Complete the operations of laying, tamping and irrigating for any piece of sod within eight hours.
- 3. Sod Maintenance
 - a. In the absence of adequate rainfall, water daily during the first week or as often and sufficiently as necessary to maintain moist soil to a depth of 4 inches. Water sod during the heat of the day to prevent wilting.
 - b. After the first week, sod watering is required as necessary to maintain adequate moisture content.
 - c. Do not mow until the sod is firmly rooted. No more than 1/2 of the grass leaf must be removed by the initial cutting or subsequent cuttings. Maintain a grass height of at least 3 inches unless otherwise specified.

B-4.4 STANDARDS AND SPECIFICATIONS

FOR

TEMPORARY STABILIZATION

Definition

To stabilize disturbed soils with vegetation for up to 6 months.

Purpose

To use fast growing vegetation that provides cover on disturbed soils.

Conditions Where Practice Applies

Exposed soils where ground cover is needed for a period of 6 months or less. For longer duration of time, permanent stabilization practices are required.

Criteria

- 1. Select one or more of the species or seed mixtures listed in Table B.1 for the appropriate Plant Hardiness Zone (from Figure B.3), and enter them in the Temporary Seeding Summary below along with application rates, seeding dates and seeding depths. If this Summary is not put on the plan and completed, then Table B.1 plus fertilizer and lime rates must be put on the plan.
- 2. For sites having soil tests performed, use and show the recommended rates by the testing agency. Soil tests are not required for Temporary Seeding.
- 3. When stabilization is required outside of a seeding season, apply seed and mulch or straw mulch alone as prescribed in Section B-4-3.A.1.b and maintain until the next seeding season.

Temporary Seeding Summary

Hardiness Zone (from Figure B.3): <u>6b</u>					Fertilizer Rate (10-20-20)	Lime Rate
Seed Mixture (from Table B.1): <u>ANNUAL RYEGRASS/FOXTAIL MILLET</u>						
No.	Species	Application Rate (lb/ac)	Seeding Dates	Seeding Depths		
	ANNUAL RYEGRASS	40	5/1 - 5/15 8/1 - 10/15	0.5	436 lb/ac (10 lb/1000 sf)	2 tons/ac (90 lb/1000 sf)
	FOXTAIL MILLET	30	5/16 - 7/31	0.5		

B-4.2 STANDARDS AND SPECIFICATIONS

FOR

SOIL PREPARATION, TOPSOILING, AND SOIL AMENDMENTS

Definition

The process of preparing the soils to sustain adequate vegetative stabilization.

Purpose

To provide a suitable soil medium for vegetative growth.

Conditions Where Practice Applies

Where vegetative stabilization is to be established.

Criteria

- A. Soil Preparation
 - 1. Temporary Stabilization
 - a. Seedbed preparation consists of loosening soil to a depth of 3 to 5 inches by means of suitable agricultural or construction equipment, such as disc harrows or chisel plows or rippers mounted on construction equipment. After the soil is loosened, it must not be rolled or dragged smooth but left in the roughened condition. Slopes 3:1 or flatter are to be tracked with ridges running parallel to the contour of the slope.
 - b. Apply fertilizer and lime as prescribed on the plans.
 - c. Incorporate lime and fertilizer into the top 3 to 5 inches of soil by disking or other suitable means.
 - 2. Permanent Stabilization
 - a. A soil test is required for any earth disturbance of 5 acres or more. The minimum soil conditions required for permanent vegetative establishment are:
 - i. Soil pH between 6.0 and 7.0.
 - ii. Soluble salts less than 500 parts per million (ppm).
 - iii. Soil contains less than 40 percent clay but enough fine grained material (greater than 30 percent silt plus clay) to provide the capacity to hold a moderate amount of moisture. An exception: if lovegrass will be planted, then a sandy soil (less than 30 percent silt plus clay) would be acceptable.
 - iv. Soil contains 1.5 percent minimum organic matter by weight.
 - v. Soil contains sufficient pore space to permit adequate root penetration.
 - b. Application of amendments or topsoil is required if on-site soils do not meet the above conditions.
 - c. Graded areas must be maintained in a true and even grade as specified on the approved plan, then scarified or otherwise loosened to a depth of 3 to 5 inches.
 - d. Apply soil amendments as specified on the approved plan or as indicated by the results of a soil test.
 - e. Mix soil amendments into the top 3 to 5 inches of soil by disking or other suitable means. Rake lawn areas to smooth the surface, remove large objects like stones and branches, and ready the area for seed application. Loosen surface soil by dragging with a heavy chain or other equipment to roughen the surface where site conditions will not permit normal seedbed preparation. Track slopes 3:1 or flatter with tracked equipment leaving the soil in an irregular condition with ridges running parallel to the contour of the slope. Leave the top 1 to 3 inches of soil loose and friable. Seedbed loosening may be unnecessary on newly disturbed areas.

- B. Topsoiling
 - 1. Topsoil is placed over prepared subsoil prior to establishment of permanent vegetation. The purpose is to provide a suitable soil medium for vegetative growth. Soils of concern have low moisture content, low nutrient levels, low pH, materials toxic to plants, and/or unacceptable soil gradation.
 - 2. Topsoil salvaged from an existing site may be used provided it meets the standards as set forth in these specifications. Typically, the depth of topsoil to be salvaged for a given soil type can be found in the representative soil profile section in the Soil Survey published by USDA-NRCS.
 - 3. Topsoiling is limited to areas having 2:1 or flatter slopes where:
 - a. The texture of the exposed subsoil/parent material is not adequate to produce vegetative growth.
 - b. The soil material is so shallow that the rooting zone is not deep enough to support plants or furnish continuing supplies of moisture and plant nutrients.
 - c. The original soil to be vegetated contains material toxic to plant growth.
 - d. The soil is so acidic that treatment with limestone is not feasible.
 - 4. Areas having slopes steeper than 2:1 require special consideration and design.
 - 5. Topsoil Specifications: Soil to be used as topsoil must meet the following criteria:
 - a. Topsoil must be a loam, sandy loam, clay loam, silt loam, sandy clay loam, or loamy sand. Other soils may be used if recommended by an agronomist or soil scientist and approved by the appropriate approval authority. Topsoil must not be a mixture of contrasting textured subsoils and must contain less than 5 percent by volume of cinders, stones, slag, coarse fragments, gravel, sticks, roots, trash, or other materials larger than 1 1/2 inches in diameter.
 - b. Topsoil must be free of noxious plants or plant parts such as Bermuda grass, quack grass, Johnson grass, nut sedge, poison ivy, thistle, or others as specified.
 - c. Topsoil substitutes or amendments, as recommended by a qualified agronomist or soil scientist and approved by the appropriate approval authority, may be used in lieu of natural topsoil.
 - 6. Topsoil Application
 - a. Erosion and sediment control practices must be maintained when applying topsoil.
 - b. Uniformly distribute topsoil in a 5 to 8 inch layer and lightly compact to a minimum thickness of 4 inches. Spreading is to be performed in such a manner that sodding or seeding can proceed with a minimum of additional soil preparation and tillage. Any irregularities in the surface resulting from topsoiling or other operations must be corrected in order to prevent the formation of depressions or water pockets.
 - c. Topsoil must not be placed if the topsoil or subsoil is in a frozen or muddy condition, when the subsoil is excessively wet or in a condition that may otherwise be detrimental to proper grading

- C. Soil Amendments (Fertilizer and Lime Specifications)
 - and seedbed preparation.
 - 1. Soil tests must be performed to determine the exact ratios and application rates for both lime and fertilizer on sites having disturbed areas of 5 acres or more. Soil analysis may be performed by a recognized private or commercial laboratory. Soil samples taken for engineering purposes may also be used for chemical analyses.
 - 2. Fertilizers must be uniform in composition, free flowing and suitable for accurate application by appropriate equipment. Manure may be substituted for fertilizer with prior approval from the appropriate approval authority. Fertilizers must all be delivered to the site fully labeled according to the applicable laws and must bear the name, trade name or trademark and warranty of the producer.
 - 3. Lime materials must be ground limestone (hydrated or burnt lime may be substituted except when hydroseeding) which contains at least 50 percent total oxides (calcium oxide plus magnesium oxide). Limestone must be ground to such fineness that at least 50 percent will pass through a #100 mesh sieve and 98 to 100 percent will pass through a #20 mesh sieve.
 - 4. Lime and fertilizer are to be evenly distributed and incorporated into the top 3 to 5 inches of soil by disking or other suitable means.
 - 5. Where the subsoil is either highly acidic or composed of heavy clays, spread ground limestone at the rate of 4 to 8 tons/acre (200-400 pounds per 1,000 square feet) prior to the placement of topsoil.

B-4 STANDARDS AND SPECIFICATIONS

FOR

VEGETATIVE STABILIZATION

Definition

Using vegetation as cover to protect exposed soil from erosion.

Purpose

To promote the establishment of vegetation on exposed soil.

Conditions Where Practice Applies

On all disturbed areas not stabilized by other methods. This specification is divided into sections on incremental stabilization; soil preparation, soil amendments and topsoiling; seeding and mulching; temporary stabilization; and permanent stabilization.

Effects on Water Quality and Quantity

Stabilization practices are used to promote the establishment of vegetation on exposed soil. When soil is stabilized with vegetation, the soil is less likely to erode and more likely to allow infiltration of rainfall, thereby reducing sediment loads and runoff to downstream areas.

Planting vegetation in disturbed areas will have an effect on the water budget, especially on volumes and rates of runoff, infiltration, evaporation, transpiration, percolation, and groundwater recharge. Over time, vegetation will increase organic matter content and improve the water holding capacity of the soil and subsequent plant growth.

Vegetation will help reduce the movement of sediment, nutrients, and other chemicals carried by runoff to receiving waters. Plants will also help protect groundwater supplies by assimilating those substances present within the root zone.

Sediment control practices must remain in place during grading, seedbed preparation, seeding, mulching, and vegetative establishment.

Adequate Vegetative Establishment

Inspect seeded areas for vegetative establishment and make necessary repairs, replacements, and reseedings within the planting season.

- 1. Adequate vegetative stabilization requires 95 percent groundcover.
- 2. If an area has less than 40 percent groundcover, restabilize following the original recommendations for lime, fertilizer, seedbed preparation, and seeding.
- 3. If an area has between 40 and 94 percent groundcover, over-seed and fertilize using half of the rates originally specified.
- 4. Maintenance fertilizer rates for permanent seeding are shown in Table B.6.

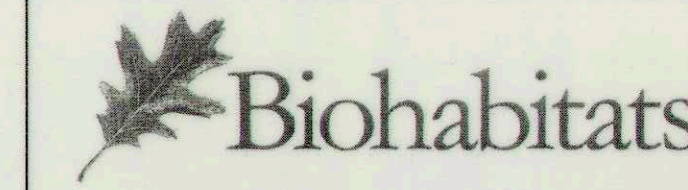

The Stables Building 2081 Clipper Park Road
Baltimore, MD 21211 / ph: 410.554.0156
fx: 410.554.0168 / www.biohabitats.com
Restore the Earth & Inspire Ecological Stewardship

**CHURCHILL WAY
OUTFALL
STABILIZATION**

SITE ADDRESS: 10430 CHURCHILL WAY, LAUREL, MD
ZONING: R-20 TAX MAP/GRID/PARCEL: 0042/0019/0081
ELECTION DISTRICT: 08 HOWARD COUNTY OPEN SPACE

**EROSION AND
SEDIMENT
CONTROL DETAILS**

PROJECT NO.: 13005.47 SCALE: NTS
SEAL: BY: KT CHECK: MDT/BVL
DWS NO.:

STATE OF MARYLAND
SHEPHERD W. LOGG
PROFESSIONAL ENGINEER
10-18-2017

8 OF 9

This development plan is approved for soil erosion and sediment control by the HOWARD SOIL CONSERVATION DISTRICT

Howard SCD Date: 10/30/17

DEPARTMENT OF PUBLIC WORKS, HOWARD COUNTY, MD

Chief, Bureau of Environmental Services Date: 10/19/17

SEQUENCE OF CONSTRUCTION

EROSION AND SEDIMENT CONTROL SETUP - 1 WEEK

1. THE CONTRACTOR SHALL STAKE OUT THE LIMITS OF DISTURBANCE AS SHOWN ON THE GRADING PLAN. STREAM CHANNEL MUST NOT BE DISTURBED DURING CLOSURE PERIOD FROM MARCH 1 TO MAY 31. (1 DAY) THIS PROJECT IS SUBJECT TO THE FOLLOWING APPROVALS:
 - 1.1. U.S. ARMY CORPS OF ENGINEERS NONTIDAL WETLANDS AND WATERWAYS PERMIT CENAB-OP-RMN (HO SVM/CHURCHILL CHANNEL STABILIZATION) 2017-61366
 - 1.2. MDE NONTIDAL WETLANDS AND WATERWAYS PERMIT AUTHORIZATION #201761366/17-NT-3225
 - 1.3. OBTAIN GRADING PERMIT FROM DILP
2. THE CONTRACTOR SHALL CONDUCT A PRE-CONSTRUCTION MEETING ONSITE WITH SEDIMENT CONTROL INSPECTOR AND THE ENGINEER TO REVIEW THE LIMITS OF DISTURBANCE, EROSION AND SEDIMENT CONTROL REQUIREMENTS, AND THE SEQUENCE OF CONSTRUCTION. THE PARTICIPANTS WILL ALSO VERIFY THE LOCATION OF THE TEMPORARY STOCKPILE AREA AND ANY NECESSARY STAGING AREA, AND FLAG ANY TREES WITHIN THE LIMITS OF DISTURBANCE WHICH WILL BE REMOVED FOR CONSTRUCTION ACCESS AND GRADING. (1 DAY)
3. THE CONTRACTOR SHALL INSTALL THE STABILIZED CONSTRUCTION ENTRANCE AS SHOWN ON THE GRADING PLANS OR AS DIRECTED BY THE ENGINEER. (1 DAY)
4. CLEAR CORRIDOR ALONG THE STREAM AND OUTFALL CHANNEL AS REQUIRED TO INSTALL THE MULCH ACCESS ROAD IN THE LOCATION DEPICTED ON THE PLANS. CARE SHOULD BE TAKEN TO MINIMIZE ANY UNNECESSARY DISTURBANCE TO EXISTING VEGETATION AND ROOT ZONES. INSTALL MULCH ACCESS ROAD AND STABILIZE DISTURBED AREAS WITH SEED AND MULCH OR SOIL STABILIZATION MATTING (SSM) AS WORK PROGRESSES. (1 DAY)
5. THE CONTRACTOR SHALL ESTABLISH THE TEMPORARY STOCKPILE AREA IN THE LOCATION INDICATED ON THE GRADING PLAN (NOTE: INSTALL SUPER SILT FENCE AROUND THE PERIMETER OF THE STOCKPILE AREA AS SHOWN). (1 DAY)
6. INSTALL REMAINING PERIMETER EROSION AND SEDIMENT CONTROL DEVICES AS SHOWN ON THE PLANS, INCLUDING BLAZE ORANGE FENCE AND TREE PLANKING. (1 DAY)

NOTES:

11. A THREE DAY DRY WEATHER PERIOD PER THE NOAA FORECAST IS REQUIRED PRIOR TO INITIATING STREAM WORK.

HOWARD SOIL CONSERVATION DISTRICT STANDARD (HSCD)

SEDIMENT CONTROL NOTES

1. A PRE-CONSTRUCTION MEETING MUST OCCUR WITH THE HOWARD COUNTY DEPARTMENT OF PUBLIC WORKS, CONSTRUCTION INSPECTION DIVISION (CID), 410-313-1855 AFTER THE FUTURE LOD AND PROTECTED AREAS ARE MARKED CLEARLY IN THE FIELD. A MINIMUM OF 48 HOUR NOTICE TO CID MUST BE GIVEN AT THE FOLLOWING STAGES:
 - a. PRIOR TO THE START OF EARTH DISTURBANCE,
 - b. UPON COMPLETION OF THE INSTALLATION OF PERIMETER EROSION AND SEDIMENT CONTROLS, BUT BEFORE PROCEEDING WITH ANY OTHER EARTH DISTURBANCE OR GRADING,
 - c. PRIOR TO THE START OF ANOTHER PHASE OF CONSTRUCTION OR OPENING OF ANOTHER GRADING UNIT,
 - d. PRIOR TO THE REMOVAL OR MODIFICATION OF SEDIMENT CONTROL PRACTICES.

OTHER BUILDING OR GRADING INSPECTION APPROVALS MAY NOT BE AUTHORIZED UNTIL THIS INITIAL APPROVAL BY THE INSPECTION AGENCY IS MADE. OTHER RELATED STATE AND FEDERAL PERMITS SHALL BE REFERENCED, TO ENSURE COORDINATION AND TO AVOID CONFLICTS WITH THIS PLAN.
2. ALL VEGETATIVE AND STRUCTURAL PRACTICES ARE TO BE INSTALLED ACCORDING TO THE PROVISIONS OF THIS PLAN AND ARE TO BE IN CONFORMANCE WITH THE 2011 MARYLAND STANDARDS AND SPECIFICATIONS FOR SOIL EROSION AND SEDIMENT CONTROL, AND REVISIONS THERETO.
3. FOLLOWING INITIAL SOIL DISTURBANCE OR RE-DISTURBANCE, PERMANENT OR TEMPORARY STABILIZATION IS REQUIRED WITHIN THREE (3) CALENDAR DAYS AS TO THE SURFACE OF ALL PERIMETER CONTROLS, DIKES, SWALES, DITCHES, PERIMETER SLOPES, AND ALL SLOPES STEEPER THAN 3 HORIZONTAL TO 1 VERTICAL (3:1); AND SEVEN (7) CALENDAR DAYS AS TO ALL OTHER DISTURBED AREAS ON THE PROJECT SITE EXCEPT FOR THOSE AREAS UNDER ACTIVE GRADING.
4. ALL DISTURBED AREAS MUST BE STABILIZED WITHIN THE TIME PERIOD SPECIFIED ABOVE IN ACCORDANCE WITH THE 2011 MARYLAND STANDARDS AND SPECIFICATIONS FOR SOIL EROSION AND SEDIMENT CONTROL FOR TOPSOIL (SEC. B-4-2), PERMANENT SEEDING (SEC. B-4-5), TEMPORARY SEEDING (SEC. B-4-4) AND MULCHING (SEC. B-4-3). TEMPORARY STABILIZATION WITH MULCH ALONE CAN ONLY BE APPLIED BETWEEN THE FALL AND SPRING SEEDING DATES IF THE GROUND IS FROZEN. INCREMENTAL STABILIZATION (SEC. B-4-1) SPECIFICATIONS SHALL BE ENFORCED IN AREAS WITH >15' OF CUT AND/OR FILL. STOCKPILES (SEC. B-4-8) IN EXCESS OF 20 FT. MUST BE BENCHED WITH STABLE OUTLET. ALL CONCENTRATED FLOW, STEEP SLOPE, AND HIGHLY ERODIBLE AREAS SHALL RECEIVE SOIL STABILIZATION MATTING (SEC. B-4-6).
5. ALL SEDIMENT CONTROL STRUCTURES ARE TO REMAIN IN PLACE, AND ARE TO BE MAINTAINED IN OPERATIVE CONDITION UNTIL PERMISSION FOR THEIR REMOVAL HAS BEEN OBTAINED FROM THE CID.
6. SITE ANALYSIS:

TOTAL AREA OF SITE:	0.3 ACRES
AREA DISTURBED:	0.3 ACRES
AREA TO BE ROOFED OR PAVED:	0.0 ACRES
AREA TO BE VEGETATIVELY STABILIZED:	0.3 ACRES
TOTAL CUT:	91 CU. YDS.
TOTAL FILL:	16 CU. YDS.
OFFSITE WASTE/BORROW AREA LOCATION:	TBD AS APPROVED BY CID; SITE MUST HAVE AN ACTIVE GRADING PERMIT
7. ANY SEDIMENT CONTROL PRACTICE WHICH IS DISTURBED BY GRADING ACTIVITY FOR PLACEMENT OF UTILITIES MUST BE REPAIRED ON THE SAME DAY OF DISTURBANCE.
8. ADDITIONAL SEDIMENT CONTROL MUST BE PROVIDED, IF DEEMED NECESSARY BY THE CID. THE SITE AND ALL CONTROLS SHALL BE INSPECTED BY THE CONTRACTOR WEEKLY; AND THE NEXT DAY AFTER EACH RAIN EVENT. A WRITTEN REPORT BY THE CONTRACTOR, MADE AVAILABLE UPON REQUEST, IS PART OF EVERY INSPECTION AND SHOULD INCLUDE:
 - INSPECTION DATE
 - INSPECTION TYPE (ROUTINE, PRE-STORM EVENT, DURING RAIN EVENT)
 - NAME AND TITLE OF INSPECTOR
 - WEATHER INFORMATION (CURRENT CONDITIONS AS WELL AS TIME AND AMOUNT OF LAST RECORDED PRECIPITATION)
 - BRIEF DESCRIPTION OF PROJECT'S STATUS (E.G., PERCENT COMPLETE) AND/OR CURRENT ACTIVITIES
 - EVIDENCE OF SEDIMENT DISCHARGES
 - IDENTIFICATION OF PLAN DEFICIENCIES
 - IDENTIFICATION OF SEDIMENT CONTROLS THAT REQUIRE MAINTENANCE
 - IDENTIFICATION OF MISSING OR IMPROPERLY INSTALLED SEDIMENT CONTROLS
 - COMPLIANCE STATUS REGARDING THE SEQUENCE OF CONSTRUCTION AND STABILIZATION REQUIREMENTS
 - PHOTOGRAPHS
 - MONITORING/SAMPLING
 - MAINTENANCE AND/OR CORRECTIVE ACTION PERFORMED
 - OTHER INSPECTION ITEMS AS REQUIRED BY THE GENERAL PERMIT FOR STORMWATER ASSOCIATED WITH CONSTRUCTION ACTIVITIES (NPDES, MDE).
9. TRENCHES FOR THE CONSTRUCTION OF UTILITIES IS LIMITED TO THREE PIPE LENGTHS OR THAT WHICH CAN AND SHALL BE BACK-FILLED AND STABILIZED BY THE END OF EACH WORKDAY, WHICHEVER IS SHORTER.
10. ANY MAJOR CHANGES OR REVISIONS TO THE PLAN OR SEQUENCE OF CONSTRUCTION MUST BE REVIEWED AND APPROVED BY THE HSCD PRIOR TO PROCEEDING WITH CONSTRUCTION. MINOR REVISIONS MAY ALLOWED BY THE CID PER THE LIST OF HSCD-APPROVED FIELD CHANGES.
11. DISTURBANCE SHALL NOT OCCUR OUTSIDE THE L.O.D. A PROJECT IS TO BE SEQUENCED SO THAT GRADING ACTIVITIES BEGIN ON ONE GRADING UNIT (MAXIMUM ACREAGE OF 20 AC. PER GRADING UNIT) AT A TIME. WORK MAY PROCEED TO A SUBSEQUENT GRADING UNIT WHEN AT LEAST 50 PERCENT OF THE DISTURBED AREA IN THE PRECEDING GRADING UNIT HAS BEEN STABILIZED AND APPROVED BY THE CID. UNLESS OTHERWISE SPECIFIED AND APPROVED BY THE CID, NO MORE THAN 30 ACRES CUMULATIVELY MAY BE DISTURBED AT A GIVEN TIME.
12. WASH WATER FROM ANY EQUIPMENT, VEHICLES, WHEELS, PAVEMENT, AND OTHER SOURCES MUST BE TREATED IN A SEDIMENT BASIN OR OTHER APPROVED WASHOUT STRUCTURE.
13. TOPSOIL SHALL BE STOCKPILED AND PRESERVED ON-SITE FOR REDISTRIBUTION ONTO FINAL GRADE.
14. ALL SILT FENCE AND SUPER SILT FENCE SHALL BE PLACED ON-THE-CONTOUR, AND BE IMBRICATED AT 25' MINIMUM INTERVALS, WITH LOWER ENDS CURLED UPHILL BY 2' IN ELEVATION.
15. STREAM CHANNELS MUST NOT BE DISTURBED DURING THE FOLLOWING RESTRICTED TIME PERIODS (INCLUSIVE):
 - USE I AND IP MARCH 1 - JUNE 15
 - USE III AND IIIIP OCTOBER 1 - APRIL 30
 - USE IV MARCH 1 - MAY 31
16. A COPY OF THIS PLAN, THE 2011 MARYLAND STANDARDS AND SPECIFICATIONS FOR SOIL EROSION AND SEDIMENT CONTROL, AND ASSOCIATED PERMITS SHALL BE ON-SITE AND AVAILABLE WHEN THE SITE IS ACTIVE.

SEDIMENT CONTROL NOTES

1. THE CONTRACTOR SHALL NOTIFY "MISS-UTILITY" AT 1-800-257-7777 AT LEAST 48 HOURS PRIOR TO ANY EXCAVATION WORK BEING DONE.
2. CONSTRUCTION ACTIVITIES INCLUDING THE INSTALLATION OF EROSION AND SEDIMENT CONTROL MEASURES SHALL NOT BEGIN UNTIL ALL REQUIRED EASEMENTS AND RIGHT-OF-WAYS HAVE BEEN OBTAINED.
3. CONSTRUCTION SHALL NOT BEGIN UNTIL ALL SEDIMENT AND EROSION CONTROL MEASURES HAVE BEEN INSTALLED AND APPROVED BY THE ENGINEER AND THE SEDIMENT CONTROL INSPECTOR.
4. THE CONTRACTOR SHALL STAY WITHIN THE LIMIT OF DISTURBANCE AS SHOWN ON THE PLANS AND MINIMIZE DISTURBANCE WITHIN THE WORKING AREA WHEREVER POSSIBLE. NO TREES SHALL BE REMOVED WITHIN THE LIMIT OF DISTURBANCE WITHOUT APPROVAL FROM THE ENGINEER.
5. THE CONSTRUCTION SEQUENCE MUST BE FOLLOWED UNLESS THE CONTRACTOR GETS WRITTEN APPROVAL FROM THE HOWARD COUNTY SOIL CONSERVATION DISTRICT OR THE SEDIMENT CONTROL INSPECTOR.
6. DO NOT CLEAR AND GRUB THE ENTIRE PROJECT AREA. CLEAR AND GRUB ONLY AS DIRECTED BY THE ENGINEER AND ONLY WHERE CONSTRUCTION ACCESS IS NEEDED.
7. FOR ALL ASPECTS OF CONSTRUCTION FOLLOWING INITIAL SOIL DISTURBANCE OR RE-DISTURBANCE, PERMANENT OR TEMPORARY STABILIZATION MUST BE COMPLETED WITHIN:
 - 8.1. THREE (3) CALENDAR DAYS AS TO THE SURFACE OF ALL PERIMETER DIKES, SWALES, DITCHES, PERIMETER SLOPES, AND ALL SLOPES STEEPER THAN 3 HORIZONTAL TO 1 VERTICAL (3:1); AND
 - 8.2. SEVEN (7) CALENDAR DAYS AS TO ALL OTHER DISTURBED OR GRADED AREAS ON THE PROJECT SITE NOT UNDER ACTIVE GRADING.
9. ANY SEDIMENT CONTROL PRACTICE THAT IS DISTURBED BY GRADING ACTIVITY FOR PLACEMENT OF UTILITIES MUST BE REPAIRED ON THE SAME DAY OF DISTURBANCE.
10. ADDITIONAL SEDIMENT CONTROL MUST BE PROVIDED, IF DEEMED NECESSARY BY THE HOWARD COUNTY SEDIMENT CONTROL INSPECTOR.
11. TRENCHES FOR THE CONSTRUCTION OF UTILITIES IS LIMITED TO THREE PIPE LENGTHS OR THAT WHICH SHALL BE BACK-FILLED AND STABILIZED BY THE END OF EACH WORK DAY, WHICHEVER IS SHORTER.

2011 MD STANDARDS & SPECIFICATIONS FOR SOIL EROSION AND SEDIMENT CONTROL - B-4-8 STOCKPILE AREA

DEFINITION - A MOUND OR PILE OF SOIL PROTECTED BY APPROPRIATELY DESIGNED EROSION AND SEDIMENT CONTROL MEASURES.

PURPOSE - TO PROVIDE A DESIGNATED LOCATION FOR THE TEMPORARY STORAGE OF SOIL THAT CONTROLS THE POTENTIAL FOR EROSION, SEDIMENTATION, AND CHANGES TO DRAINAGE PATTERNS. CONDITIONS WHERE PRACTICE APPLIES - STOCKPILE AREAS ARE UTILIZED WHEN IT IS NECESSARY TO SALVAGE AND STORE SOIL FOR LATER USE.

CRITERIA:

1. THE STOCKPILE LOCATION AND ALL RELATED SEDIMENT CONTROL PRACTICES MUST BE CLEARLY INDICATED ON THE EROSION AND SEDIMENT CONTROL PLAN.
2. THE FOOTPRINT OF THE STOCKPILE MUST BE SIZED TO ACCOMMODATE THE ANTICIPATED VOLUME OF MATERIAL AND BASED ON A SIDE SLOPE RATIO NO STEEPER THAN 2:1. BENCHING MUST BE PROVIDED IN ACCORDANCE WITH SECTION B-3 LAND GRADING.
3. RUNOFF FROM THE STOCKPILE AREA MUST DRAIN TO A SUITABLE SEDIMENT CONTROL PRACTICE.
4. ACCESS THE STOCKPILE AREA FROM THE UPGRADE SIDE.
5. CLEAR WATER RUNOFF INTO THE STOCKPILE AREA MUST BE MINIMIZED BY USE OF A DIVERSION DEVICE SUCH AS AN EARTH DIKE, TEMPORARY SWALE OR DIVERSION FENCE. PROVISIONS MUST BE MADE FOR DISCHARGING CONCENTRATED FLOW IN A NON-EROSIVE MANNER.
6. WHERE RUNOFF CONCENTRATES ALONG THE TOE OF THE STOCKPILE FILL, AN APPROPRIATE EROSION/SEDIMENT CONTROL PRACTICE MUST BE USED TO INTERCEPT THE DISCHARGE.
7. STOCKPILES MUST BE STABILIZED IN ACCORDANCE WITH THE 3/7 DAY STABILIZATION REQUIREMENT AS WELL AS STANDARD B-4-1 INCREMENTAL STABILIZATION AND STANDARD B-4-4 TEMPORARY STABILIZATION.
8. IF THE STOCKPILE IS LOCATED ON AN IMPERVIOUS SURFACE, A LINER SHOULD BE PROVIDED BELOW THE STOCKPILE TO FACILITATE CLEANUP. STOCKPILES CONTAINING CONTAMINATED MATERIAL MUST BE COVERED WITH IMPERMEABLE SHEETING.

MAINTENANCE:

THE STOCKPILE AREA MUST CONTINUOUSLY MEET THE REQUIREMENTS FOR ADEQUATE VEGETATIVE ESTABLISHMENT IN ACCORDANCE WITH SECTION B-4 VEGETATIVE STABILIZATION. SIDE SLOPES MUST BE MAINTAINED AT NO STEEPER THAN A 2:1 RATIO. THE STOCKPILE AREA MUST BE KEPT FREE OF EROSION. IF THE VERTICAL HEIGHT OF A STOCKPILE EXCEEDS 20 FEET FOR 2:1 SLOPES, 30 FEET FOR 3:1 SLOPES, OR 40 FEET FOR 4:1 SLOPES, BENCHING MUST BE PROVIDED IN ACCORDANCE WITH SECTION B-3 LAND GRADING.

This development plan is approved for soil erosion and sediment control by the HOWARD SOIL CONSERVATION DISTRICT

[Signature] 10/20/17
Howard SCD Date

DEPARTMENT OF PUBLIC WORKS, HOWARD COUNTY, MD

[Signature] 10/18/17
CHIEF, BUREAU OF ENVIRONMENTAL SERVICES DATE

CLIENT
HOWARD COUNTY
STORMWATER MANAGEMENT DIVISION
6751 GATEWAY DRIVE, SUITE 514
COLUMBIA, MD 21046
PHONE: (410) 313-6413

DATE ISSUES / REVISIONS



CHURCHILL WAY OUTFALL STABILIZATION

SITE ADDRESS: 10430 CHURCHILL WAY, LAUREL, MD
ZONING: R-20 TAX MAP/GRID/PARCEL: 0042/0019/0081
ELECTION DISTRICT: 06 HOWARD COUNTY OPEN SPACE

EROSION AND SEDIMENT CONTROL NOTES

PROJECT NO.: 13005.47 SCALE: NTS

SEAL BY: KT CHECK: MDT/BVL

