

GENERAL NOTES

1. All work shall be performed in accordance with the Howard County Specifications and Details for Construction.
2. Elevations shown are based on the Johns Hopkins University Applied Physics Laboratory Datum. JHU-APL Datum -0.24' + Howard County Datum.
3. The contractor shall call Miss Utility (301) 552-0100, five days prior to the start of construction.
4. Poly Filter X Filter cloth blanket or equal shall be placed under all stone rip rap.
5. Approximate location of existing utilities are shown. The contractor shall take all necessary precautions to protect the existing utilities and maintain an uninterrupted service. Any damage by the contractor's operations shall be repaired immediately at the contractor's expense.
6. Landscaping shall be done by JHU-APL.
7. The contractor shall contact Mr. Arthur Stucki, Plant Engineer, (301) 953-7100 at least 5 working days prior to commencing any work.
8. All pipe elevations shown are invert (I) elevations.
9. The contractor or developer shall contact the construction inspection/survey division, 24 hours in advance of commencement of work, at 292-2417 or 2418.

SITE DATA

1. ZONING	RURAL						
2. SITE AREA	178 Ac.						
3. ACREAGE OF ENTIRE PROPERTY	304 Ac.						
4. EXISTING BUILDING COVERAGE	15.0 Ac. - 8.55%						
5. TOTAL NUMBER OF EXISTING EMPLOYEES/ PERSONNEL ON THE ENTIRE SITE	3225						
6. TOTAL NUMBER OF PARKING SPACES REQUIRED	2288						
7. TOTAL NUMBER OF PARKING SPACES PROVIDED	2494 *						
<table border="1"> <tr> <td>EXISTING SPACES</td> <td>2426</td> </tr> <tr> <td>SPACES PROPOSED</td> <td>+ 68</td> </tr> <tr> <td>* TOTAL EXISTING & PROPOSED</td> <td>2494</td> </tr> </table>		EXISTING SPACES	2426	SPACES PROPOSED	+ 68	* TOTAL EXISTING & PROPOSED	2494
EXISTING SPACES	2426						
SPACES PROPOSED	+ 68						
* TOTAL EXISTING & PROPOSED	2494						

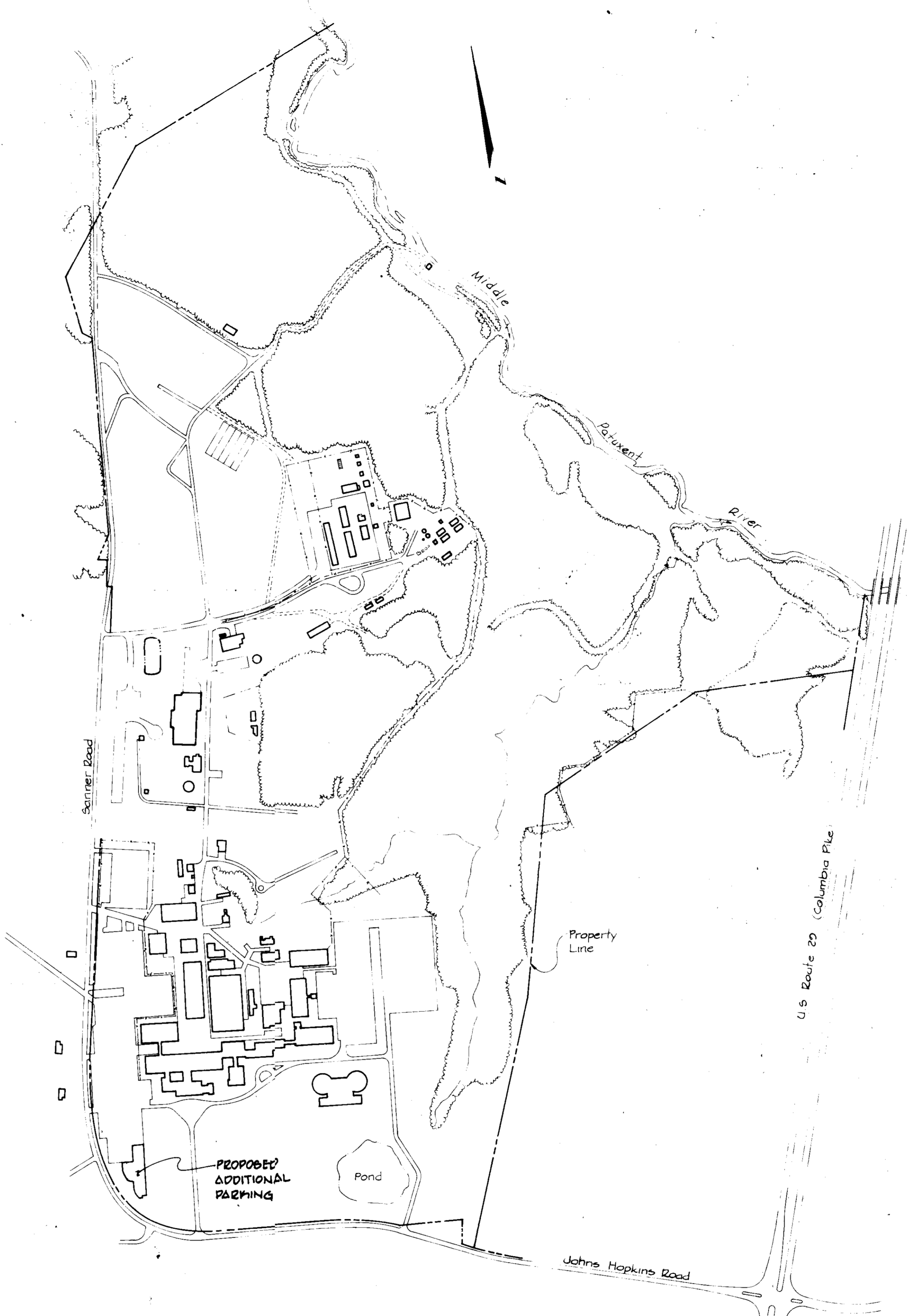

LOCATION PLAN
Scale 1" = 400'

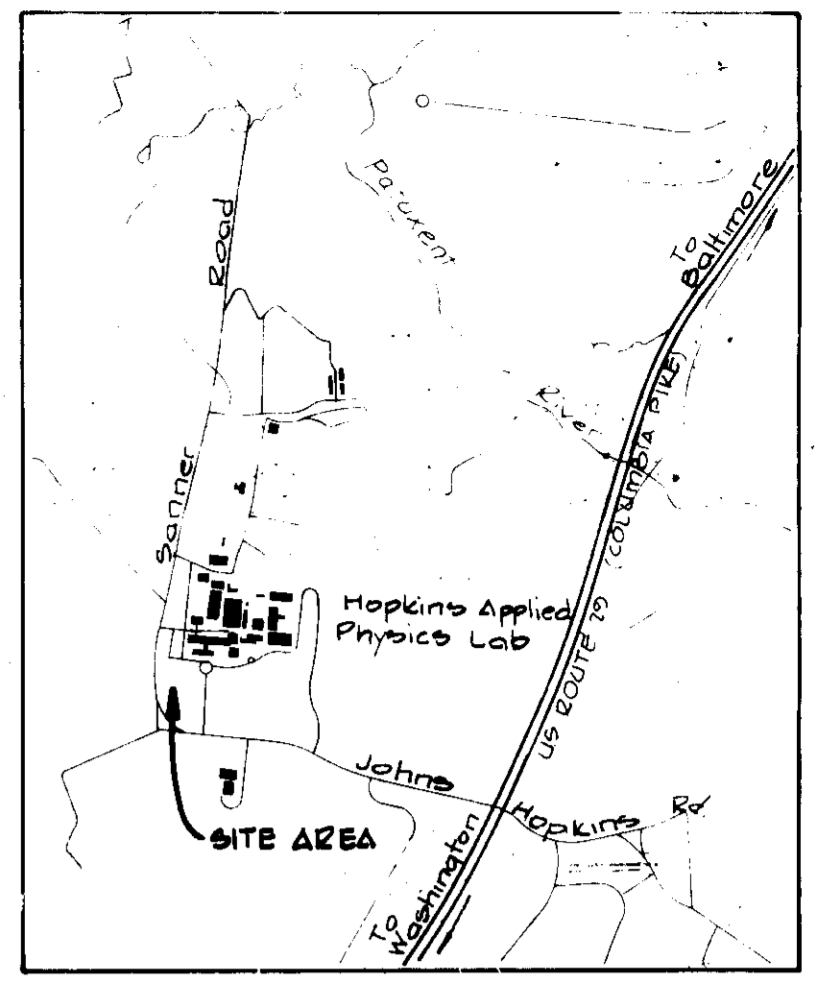

VICINITY MAP
Scale 1" = 2000'

SHEET INDEX

1. Title sheet
2. Plan
3. Profiles & Details

APPROVED
DIVISION OF LAND DEVELOPMENT &
ZONING ADMINISTRATION
HOWARD COUNTY, MARYLAND
DATE 10-13-82

Approved: For Private Water And Private Sewerage Systems, Howard County Health Department. <i>Joyce Byler</i> 11-7-82 County Health Officer Date
Approved: Storm Drainage Systems And Roads, Howard County Department Of Public Works. <i>John F. Nunn</i> 11-1-82 Director Date
Approved: Chief, Bureau Of Engineering <i>[Signature]</i> 10-29-82 Date
Approved: Howard County Office Of Planning And Zoning <i>J. Donald King</i> 11-5-82 Planning Director Date
Approved: Chief, Division Of Land Development And Zoning Administration <i>[Signature]</i> 11-5-82 Date

Note: Building Addition to SDP 82-116

WHITMAN, REQUARDT AND ASSOCIATES 2315 SAINT PAUL STREET BALTIMORE, MARYLAND 21218	<i>Robert Whitman</i> APPLIED PHYSICS LABORATORY THE JOHNS HOPKINS UNIVERSITY Johns Hopkins Road Howard County, Maryland Approved For The University By: <i>Arthur Stucki</i> Date <i>8/30/82</i> Title <i>Plant Engr.</i>	VISITOR'S PARKING LOT EXPANSION THE JOHNS HOPKINS UNIVERSITY APPLIED PHYSICS LABORATORY 11100 Johns Hopkins Road Laurel, Maryland 20707	TITLE SHEET Fifth Election District Howard County, MD. Tax Map 41 Parcel 50 and 123	REVISIONS	SCALE: As Shown SHEET NO. 1 OF 3 DATE: 9/1/82	DRAWING 1
--	---	--	--	-----------	--	-------------------------

PI # D-58-82

PLANT LIST

- EXISTING JUNIPERS
- TRANSPLANTED JUNIPERS FROM PARKING LOT, 40'S
- TRANSPLANTED WHITE PINE FROM JHU-APL PROPERTY 10'-12' HEIGHT, 10'-12' O/C, 25'S

N 484.250

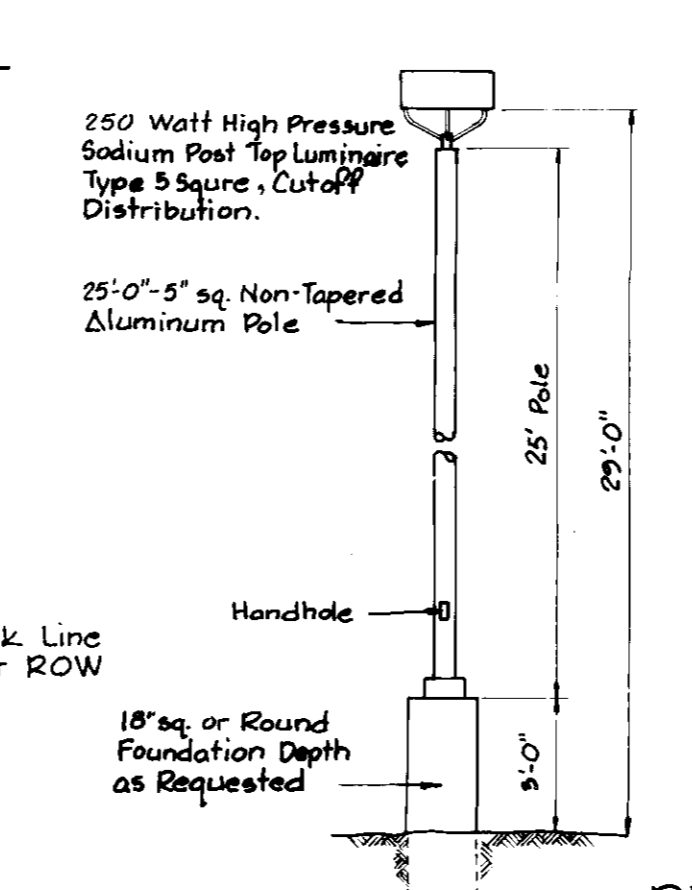
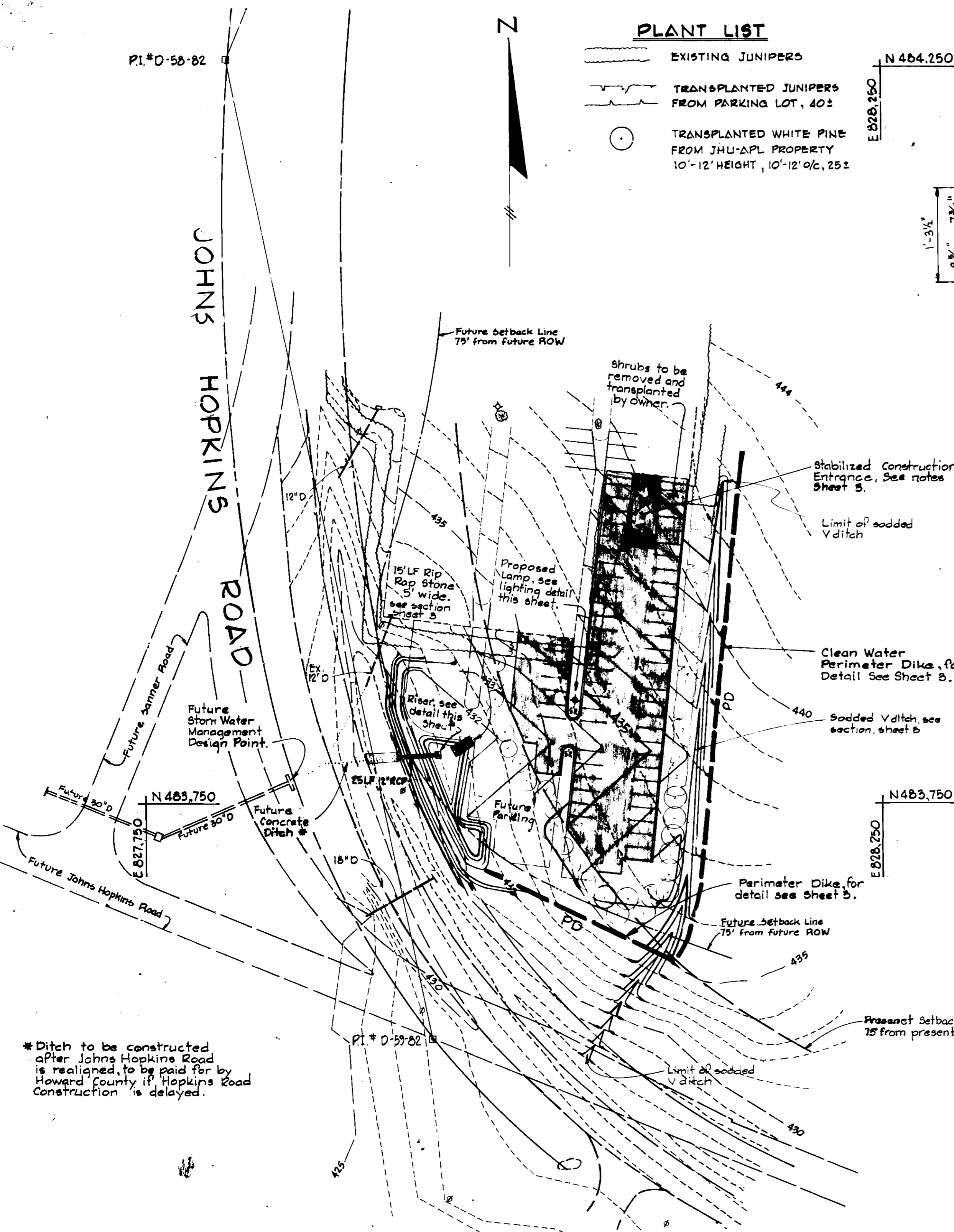
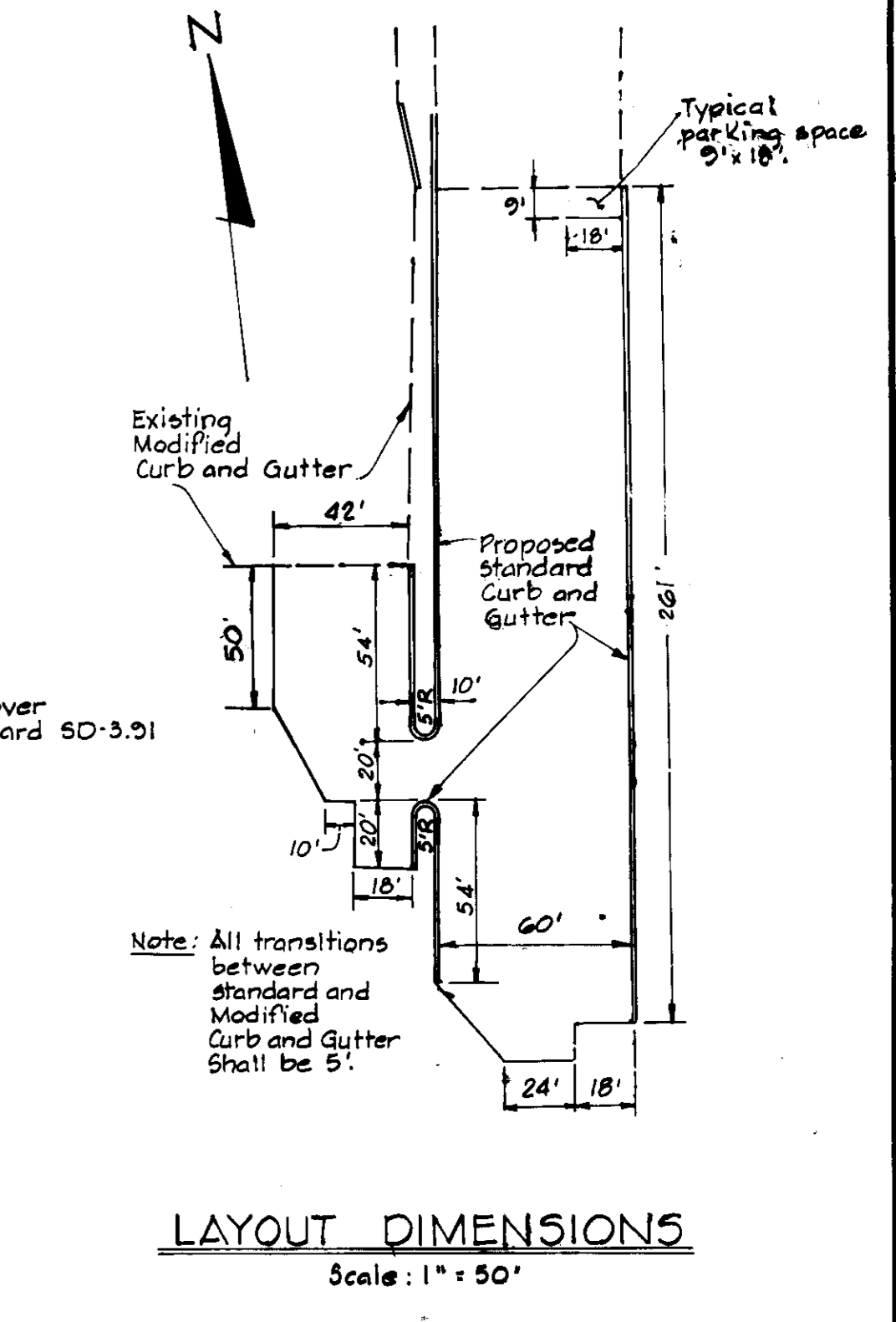
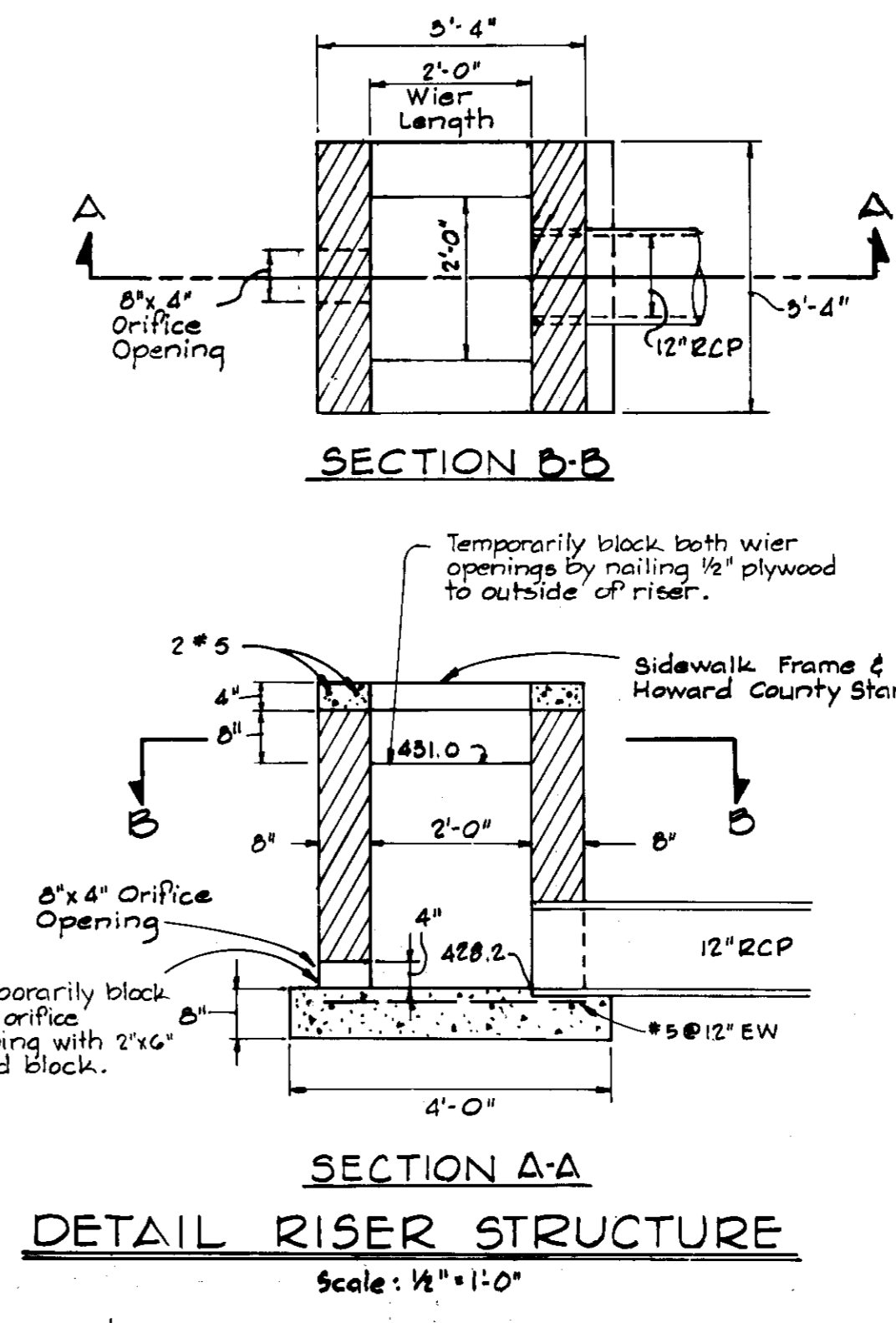
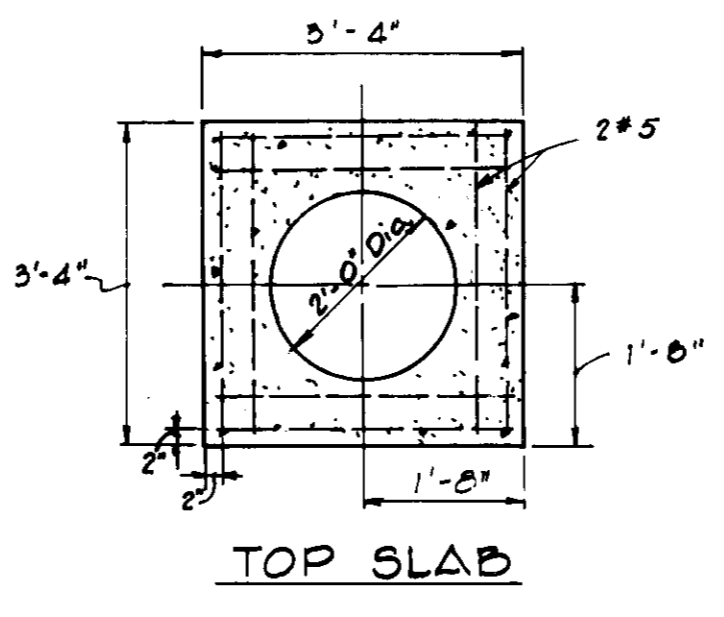
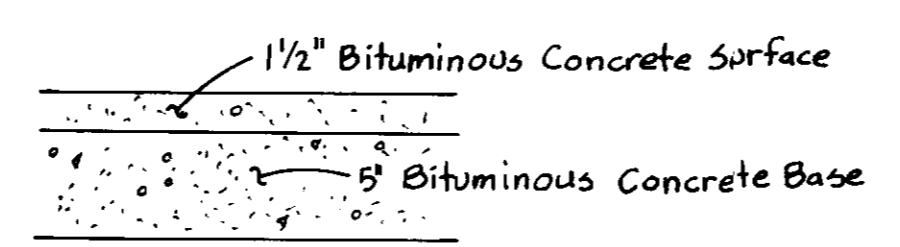
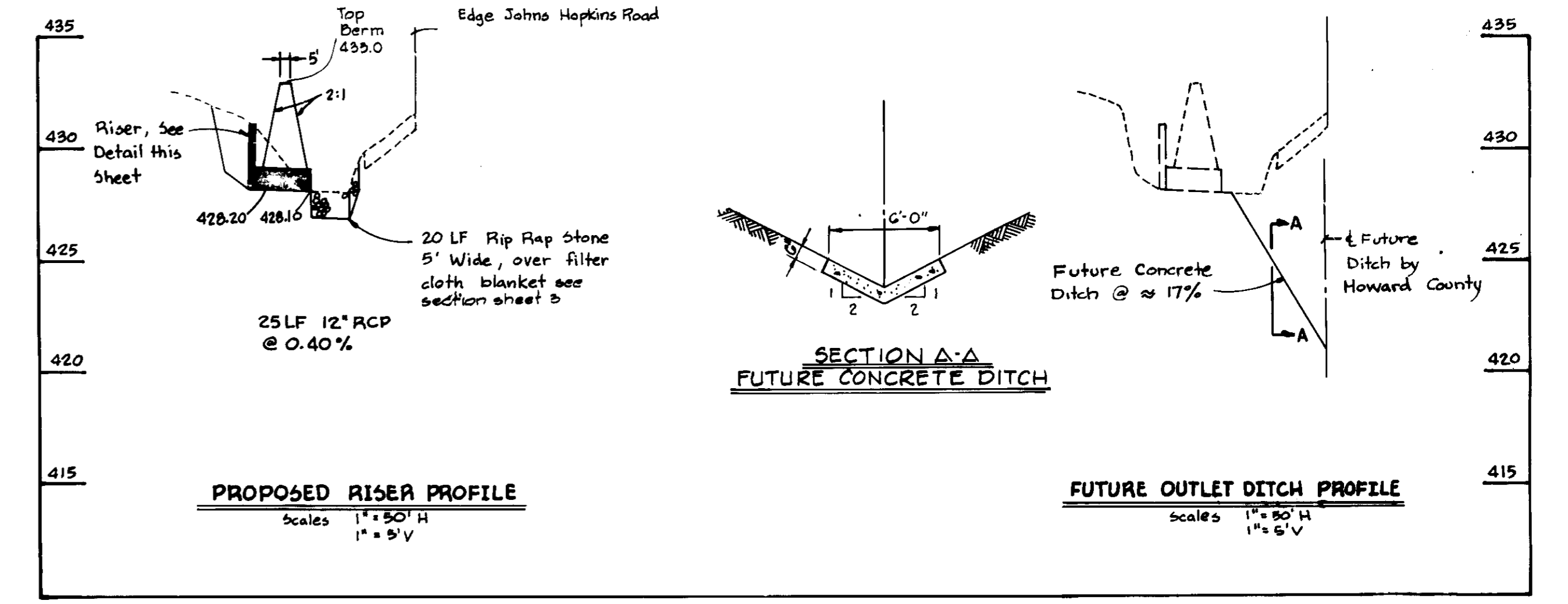
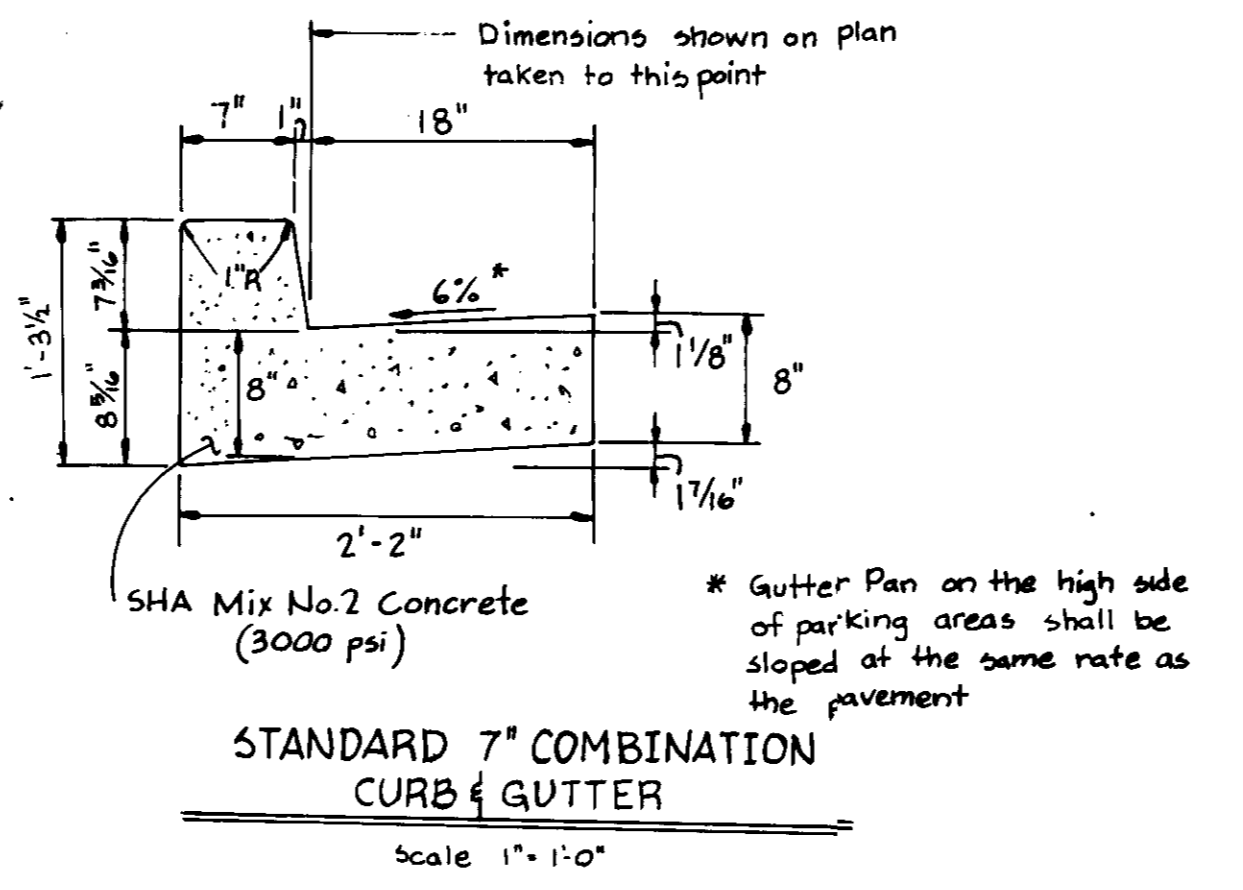

STORM WATER MANAGEMENT DATA

Year Storm	Pond Outfall (cfs)	Pond Elev.	Storage (CF)	Design Point Flow (cfs)	Max. Allowable Design Pt. Flow (cfs)
2	2.5	431.01	2,500	15.6	15.8
10	6.6	431.80	4,950	30.8	31.0
50	7.5	432.34	6,800	40.5	-
100	7.9	432.68	8,740	45.9	-

These plans have been reviewed for the Howard Soil Conservation District and meet the technical requirements for soil erosion and sediment control.

These plans for soil erosion and sediment control meet the requirements of the Howard Soil Conservation District.

RESponsible PERSONNEL CERTIFICATION
I hereby certify that any responsible personnel involved in the construction project will have a certificate of attendance from a Department of Natural Resources approved training program for the control of sediment and erosion before beginning the project.

CERTIFICATION BY THE DEVELOPER
I certify that all development and or construction will be done according to this plan of development and plan for erosion and sediment control, and I also authorize periodic on-site inspection by the Howard Soil Conservation District or their authorized agents, as deemed necessary.

Note: Building Addition to SDP 82-118
Approved: For Private Water And Private Sewerage Systems, Howard County Health Department.
Signature: *[Signature]* Date: 11-4-82
Approved: Storm Drainage Systems And Roads, Howard County Department Of Public Works
Signature: *[Signature]* Date: 11-5-82
Approved: Howard County Office Of Planning And Zoning
Signature: *[Signature]* Date: 11-5-82
Approved: Chief, Division Of Land Development And Zoning Administration
Signature: *[Signature]* Date: 11-5-82

CERTIFICATION BY THE ENGINEER
I certify that this plan for erosion and sediment control represents a practical and workable plan based on my personal knowledge of the site conditions and that it was prepared in accordance with the requirements of the Howard Soil Conservation District.

Signature: *[Signature]* Date: *[Date]*
U.S. Soil Conservation Service

Signature: *[Signature]* Date: 10/26/82
Approved: *[Signature]* Date: *[Date]*
Howard S.C.D.

APPLIED PHYSICS LABORATORY
THE JOHN'S HOPKINS UNIVERSITY
Johns Hopkins Road Howard County, Maryland
Approved For The University By: *[Signature]*
Date: 8/30/82 Title: Plant Spec.

VISITOR'S PARKING LOT EXPANSION
THE JOHN'S HOPKINS UNIVERSITY APPLIED PHYSICS LABORATORY
11100 Johns Hopkins Road Laurel, Maryland 20707

Signature: *[Signature]* Date: 8/30/82
Signature of Developer

Signature: *[Signature]* Date: 8/30/82
Signature of Developer

SEEDING CONTROL NOTES

- ALL SEDIMENT CONTROL PROCEDURES SHALL BE CARRIED OUT IN ACCORDANCE WITH THE APPROVED PLANS AND THE CRITERIA OF THE HOWARD SOIL CONSERVATION DISTRICT AND THE U.S. SOIL CONSERVATION SERVICE "STANDARDS AND SPECIFICATIONS FOR SOIL EROSION AND SEDIMENT CONTROL IN DEVELOPING AREAS" (HEREINAFTER REFERRED TO AS "STANDARDS AND SPECIFICATIONS").
- ALL DISTURBED AREAS WHICH ARE TO BE EXPOSED FOR MORE THAN 60 DAYS SHALL BE STABILIZED WITH TEMPORARY SEEDING AND MULCHING IMMEDIATELY FOLLOWING ROUGH GRADING IN ACCORDANCE WITH PAGES 50.01 THROUGH 50.03 OF THE "STANDARDS AND SPECIFICATIONS."
- THESE GRADING AND SEDIMENT CONTROL DRAWINGS SHALL BE USED FOR THE GRADING AND CONSTRUCTION OF SEDIMENT CONTROL PRACTICES ONLY. FOR ALL OTHER CONSTRUCTION SEE THE "FINAL DEVELOPMENT PLANS".
- THE STABILIZED CONSTRUCTION ENTRANCE WILL BE IN ACCORDANCE WITH PAGE 16.03 OF THE "STANDARDS AND SPECIFICATIONS".
- NO TEMPORARY SEDIMENT CONTROL DEVICE OR STRUCTURE MAY BE REMOVED OR DESTROYED WITHOUT APPROVAL OF THE HOWARD SOIL CONSERVATION DISTRICT.

SEEDING NOTES

- ALL DISTURBED AREAS ARE TO BE STABILIZED AND SEEDED AS SOON AS GRADING IS COMPLETED.
- THE SURFACE PREPARATION SHALL INCLUDE 6" OF TOPSOIL WITH AN APPLICATION OF GROUND LIMESTONE AT 50 LBS/1000 SF. LIME, WHEN APPLIED HYDRAULICALLY, SHALL BE A SINGLE, SEPARATE OPERATION.
- ALL DISTURBED AREAS ARE TO BE FERTILIZED AND SEEDED WITH A HYDROSEED SLURRY. THE SLURRY SHALL CONTAIN:
 - 10-10-10 FERTILIZER = 25 LBS/1000 SF.
 - KENTUCKY 31 TALL FESCUE = 60 LBS/ACRE.
 - KOREAN LESPEDEZA = 20 LBS/ACRE.
 - SUITABLE MULCH
- THE MULCH SHALL BE STRAW = 50 LBS/1000 SF. OR WOOD CELLULOSE = 1200 LBS/ACRE. THE WOOD CELLULOSE MULCH SHALL BE ADDED ONLY AFTER THE SEED AND FERTILIZER HAVE BEEN THOROUGHLY MIXED.
- THE FERTILIZER, SEED, AND MULCH SHALL BE MIXED WITH SUFFICIENT WATER TO PRODUCE A SLURRY. THE SLURRY SHALL BE APPLIED UNDER PRESSURE AT THE RATE SPECIFIED OR AS DIRECTED WITH HYDRAULIC EQUIPMENT APPROVED PRIOR TO USE.
- ANY AREA INADEQUATELY COVERED SHALL BE RESEED.

CONSTRUCTION SPECIFICATIONS

- SITE PREPARATION**
AREAS UNDER THE BORROW AREAS, EMBANKMENT, AND STRUCTURAL WORKS SHALL BE CLEARED, GRUBBED AND THE TOPSOIL STRIPPED TO REMOVE ALL TREES, VEGETATION, ROOTS OR OTHER OBJECTIONABLE MATERIAL. CHANNEL BANKS AND SHARP BREAKS SHALL BE SLOPED TO NO STEEPER THAN 1:1.
ALL CLEARED AND GRUBBED MATERIAL SHALL BE DISPOSED OF OUTSIDE THE LIMITS OF THE DAM AND RESERVOIR AS DIRECTED BY THE OWNER OR HIS REPRESENTATIVE. WHEN SPECIFIED, A SUFFICIENT QUANTITY OF TOPSOIL WILL BE STOCKPILED AS SHOWN ON THE PLANS FOR USE ON THE EMBANKMENT AND OTHER DESIGNATED AREAS.
- EARTH FILL**
MATERIAL
THE FILL MATERIAL SHALL BE TAKEN FROM THE APPROVED DESIGNATED BORROW AREA AS SHOWN OR AS DIRECTED BY THE ENGINEER IN THE FIELD.
IT SHALL BE FREE OF ROOTS, STUMPS, WOOD, RUBBISH, OVER SIZE STONES, FROZEN OR OTHER OBJECTIONABLE MATERIALS. THE EMBANKMENT SHALL BE CONSTRUCTED TO AN ELEVATION WHICH PROVIDES FOR ANTICIPATED SETTLEMENT TO THE DESIGN ELEVATION. THE FILL HEIGHT ALL ALONG THE LENGTH OF THE EMBANKMENT SHALL BE INCREASED ABOVE THE DESIGN ELEVATION (INCLUDING FREEBOARD) AS SHOWN ON THE PLANS.
PLACEMENT
AREAS ON WHICH FILL IS TO BE PLACED SHALL BE SCARIFIED PRIOR TO PLACEMENT OF FILL. FILL MATERIALS SHALL BE PLACED IN 8-INCH MAXIMUM THICKNESS (BEFORE COMPACTION) LAYERS WHICH ARE TO BE CONTINUOUS OVER THE ENTIRE LENGTH OF THE FILL. THE MOST POROUS BORROW MATERIAL SHALL BE PLACED IN THE DOWNSTREAM PORTIONS OF THE EMBANKMENT.
COMPACTION
THE MOVEMENT OF THE HAULING AND SPREADING EQUIPMENT OVER THE FILL SHALL BE CONTROLLED SO THAT THE ENTIRE SURFACE OF EACH LIFT SHALL BE TRAVERSED BY NOT LESS THAN ONE TREAD TRACK OF THE EQUIPMENT OR COMPACTION SHALL BE ACHIEVED BY A MINIMUM OF FOUR COMPLETE PASSES OF A SHEEPSFOOT, RUBBER Tired OR VIBRATORY ROLLER.
FILL MATERIAL SHALL CONTAIN SUFFICIENT MOISTURE SUCH THAT THE REQUIRED DEGREE OF COMPACTION CAN BE OBTAINED WITH THE EQUIPMENT USED.

CUT OFF TRENCH

A CUTOFF TRENCH SHALL BE EXCAVATED ALONG TO THE CENTERLINE OF THE EMBANKMENT AS SHOWN ON THE PLANS. THE BOTTOM WIDTH OF THE TRENCH SHALL BE GOVERNED BY THE EQUIPMENT USED FOR EXCAVATION. WITH THE MINIMUM WIDTH BEING FOUR FEET. THE DEPTH SHALL BE AT LEAST FOUR FEET OR AS SHOWN ON THE PLANS. THE SIDE SLOPES OF THE TRENCH SHALL BE 1 TO 1 OR FLATTER. THE BACKFILL MATERIAL FOR THE CUTOFF TRENCH SHALL BE THE MOST IMPERVIOUS MATERIAL AVAILABLE AND SHALL BE COMPACTED WITH EQUIPMENT OR ROLLERS TO ASSURE MAXIMUM DENSITY AND MINIMUM PERMEABILITY.

3. STRUCTURAL BACKFILL

BACKFILL MATERIAL SHALL BE OF THE TYPE AND QUALITY CONFORMING TO THAT SPECIFIED FOR THE ADJOINING FILL MATERIAL. THE FILL SHALL BE PLACED IN HORIZONTAL LAYERS NOT TO EXCEED FOUR INCHES IN THICKNESS AND COMPACTED BY HAND TAMPERS OR OTHER COMPACTION EQUIPMENT. THE MATERIAL NEEDS TO FILL COMPLETELY ALL SPACES UNDER OR ADJACENT TO A STRUCTURE. AT NO TIME DURING THE BACKFILLING OPERATION SHALL DRIVEN EQUIPMENT BE ALLOWED TO OPERATE CLOSER THAN FOUR FEET, MEASURED HORIZONTALLY, TO ANY PART OF A STRUCTURE. UNDER NO CIRCUMSTANCES SHALL THE CONTRACTOR DRIVE EQUIPMENT OVER ANY PART OF A CONCRETE STRUCTURE OR PIPE UNLESS THERE IS A COMPACTED FILL OF TWENTY-FOUR INCHES OR GREATER OVER THE STRUCTURE OR PIPE.

4. CONCRETE

- MATERIALS**
 - CEMENT - PORTLAND CEMENT SHALL CONFORM TO THE LATEST ASTM SPECIFICATION C-150.
 - WATER - THE WATER USED IN CONCRETE SHALL BE CLEAN, FREE FROM OIL, ACID, ALKALI, SCALES, ORGANIC MATTER OR OTHER OBJECTIONABLE SUBSTANCES.
 - SAND - THE SAND USED IN CONCRETE SHALL BE CLEAN, HARD, STRONG AND DURABLE, AND SHALL BE WELL GRADED WITH 100 PERCENT PASSING A ONE-QUARTER INCH SIEVE. LIMESTONE SAND SHALL NOT BE USED.
 - COARSE AGGREGATE - THE COARSE AGGREGATE SHALL BE CLEAN, HARD, STRONG AND DURABLE, AND FREE FROM CLAY OR DIRT. IT SHALL BE WELL GRADED WITH A MAXIMUM SIZE OF ONE AND ONE-HALF (1-1/2) INCHES.
 - REINFORCING STEEL - THE REINFORCING STEEL SHALL BE DEFORMED BARS OF INTERMEDIATE GRADE BILLET STEEL OR RAIL STEEL CONFORMING TO ASTM SPECIFICATIONS A-615.
- DESIGN MIX** - THE CONCRETE SHALL BE MIXED IN THE FOLLOWING PROPORTIONS, MEASURED BY WEIGHT. THE WATER-CEMENT RATIO SHALL BE 5-1/2 TO 6 U.S. GALLONS OF WATER PER 94 POUND BAG OF CEMENT. THE PROPORTION OF MATERIALS FOR THE TRIAL MIX SHALL BE 1:2:3-1/2. THE COMBINATION OF AGGREGATES MAY BE ADJUSTED TO PRODUCE A PLASTIC AND WORKABLE MIX THAT WILL NOT PRODUCE HARSHNESS IN PLACING OR HONEYCOMBING IN THE STRUCTURE.
- MIXING** - THE CONCRETE INGREDIENTS SHALL BE MIXED IN BATCH MIXERS UNTIL THE MIXTURE IS HOMOGENEOUS AND OF UNIFORM CONSISTENCY. THE MIXING OF EACH BATCH SHALL CONTINUE FOR NOT LESS THAN ONE AND ONE-HALF MINUTES AFTER ALL THE INGREDIENTS, EXCEPT THE FULL AMOUNT OF WATER, ARE IN THE MIXER. THE MINIMUM MIXING TIME IS PREDICTED ON PROPER CONTROL OF THE SPEED OF ROTATION OF THE MIXER AND OF THE INTRODUCTION OF THE MATERIALS, INCLUDING WATER, INTO THE MIXER. WATER SHALL BE ADDED PRIOR TO, DURING, AND FOLLOWING THE MIXER-CHARGING OPERATIONS. EXCESSIVE OVERMIXING REQUIRING THE ADDITION OF WATER TO PRESERVE THE REQUIRED CONCRETE CONSISTENCY SHALL NOT BE PERMITTED. TRUCK MIXING WILL BE ALLOWED PROVIDED THAT THE USE OF THIS METHOD SHALL CAUSE NO VIOLATION OF ANY APPLICABLE PROVISIONS OF THE SPECIFICATIONS GIVEN HERE.
- FORMS** - THE FORMS SHALL HAVE SUFFICIENT STRENGTH AND RIGIDITY TO HOLD THE CONCRETE AND TO WITHSTAND THE NECESSARY PRESSURE, TAMPING, AND VIBRATION WITHOUT DEFLECTION FROM THE PRESCRIBED LINES. THEY SHALL BE MORTAR-TIGHT AND CONSTRUCTED SO THAT THEY CAN BE REMOVED WITHOUT HAMMERING OR PRYING AGAINST THE CONCRETE.
THIS INSIDE OF FORMS SHALL BE OILED WITH A NON-STAINING MINERAL OIL OR THOROUGHLY WETTED BEFORE CONCRETE IS PLACED.
FORMS MAY BE REMOVED 24 HOURS AFTER THE PLACEMENT OF CONCRETE. ALL WIRE TIES AND OTHER DEVICES USED SHALL BE RECESSED FROM THE SURFACE OF THE CONCRETE.
- REINFORCING STEEL** - ALL REINFORCING MATERIAL SHALL BE FREE OF DIRT, RUST, SCALE, OIL, PAINT OR ANY OTHER COATINGS.
THE STEEL SHALL BE ACCURATELY PLACED AND SECURELY TIED AND BLOCKED INTO POSITION SO THAT NO MOVEMENT OF THE STEEL WILL OCCUR DURING PLACEMENT OF CONCRETE.
- CONSOLIDATING** - CONCRETE SHALL BE CONSOLIDATED WITH INTERNAL TYPE MECHANICAL VIBRATORS. VIBRATION SHALL BE SUPPLEMENTED BY SPADING AND HAND TAMPING AS NECESSARY TO INSURE SMOOTH AND DENSE CONCRETE ALONG FORM SURFACES, IN CORNERS, AND AROUND EMBEDDED ITEMS.
- FINISHING** - DEFECTIVE CONCRETE, HONEYCOMBED AREAS, VOIDS LEFT BY THE REMOVAL OF THE RODS, RIDGES ON ALL CONCRETE SURFACES PERMANENTLY EXPOSED TO VIEW OR EXPOSED TO WATER ON THE FINISHED STRUCTURE, SHALL BE REPAIRED IMMEDIATELY AFTER THE REMOVAL OF FORMS. ALL VOIDS SHALL BE REAMED AND COMPLETELY FILLED WITH DRY-PATCHING MORTAR.
- PROTECTION AND CURING** - EXPOSED SURFACES OF CONCRETE SHALL BE PROTECTED FROM THE DIRECT RAYS OF THE SUN FOR AT LEAST THE FIRST THREE (3) DAYS. ALL CONCRETE SHALL BE KEPT CONTINUOUSLY MOIST FOR AT LEAST TEN (10) DAYS AFTER BEING PLACED. MOISTURE MAY BE APPLIED BY SPRAYING OR SPRINKLING AS NECESSARY TO PREVENT THE CONCRETE FROM DRYING. CONCRETE SHALL NOT BE EXPOSED TO FREEZING DURING THE CURING PERIOD. CURING COMPOUNDS MAY ALSO BE USED.
- PLACING TEMPERATURE** - CONCRETE MAY NOT BE PLACED AT TEMPERATURES BELOW 37°F. WITH THE TEMPERATURE FALLING OR 34° TEMPERATURE RISING.

SEQUENCE OF CONSTRUCTION OPERATIONS

- NOTIFY THE HOWARD SOIL CONSERVATION DISTRICT AND THE HOWARD COUNTY BUREAU OF LICENSES, INSPECTIONS, AND PERMITS 48 HOURS BEFORE ANY WORK BEGINS.
- CONSTRUCT THE SEDIMENT BASIN AND PRINCIPAL SPILLWAY.
- CONSTRUCT THE DIVERSION DIKE AND SILT FENCE.
- CONSTRUCT THE PARKING AREA AND FINISH GRADING THE SITE.
- FEED AND STABILIZE THE PROPOSED GRASSED AREAS.
- PUMP THE STANDING CLEAN WATER IN SEDIMENT BASIN OVER THE TOP OPENING.
- EXCAVATE THE POND TO THE PROPOSED ELEVATIONS AND STABILIZE. DISPOSE OF THE SEDIMENT FROM THE POND IN A MANNER APPROVED BY THE HOWARD SOIL CONSERVATION DISTRICT.
- REMOVE THE TEMPORARY BLOCK OF THE 8"x4" ORIFICE OPENING AND THE TWO WIER OPENINGS. PLACE THE MH COVER.

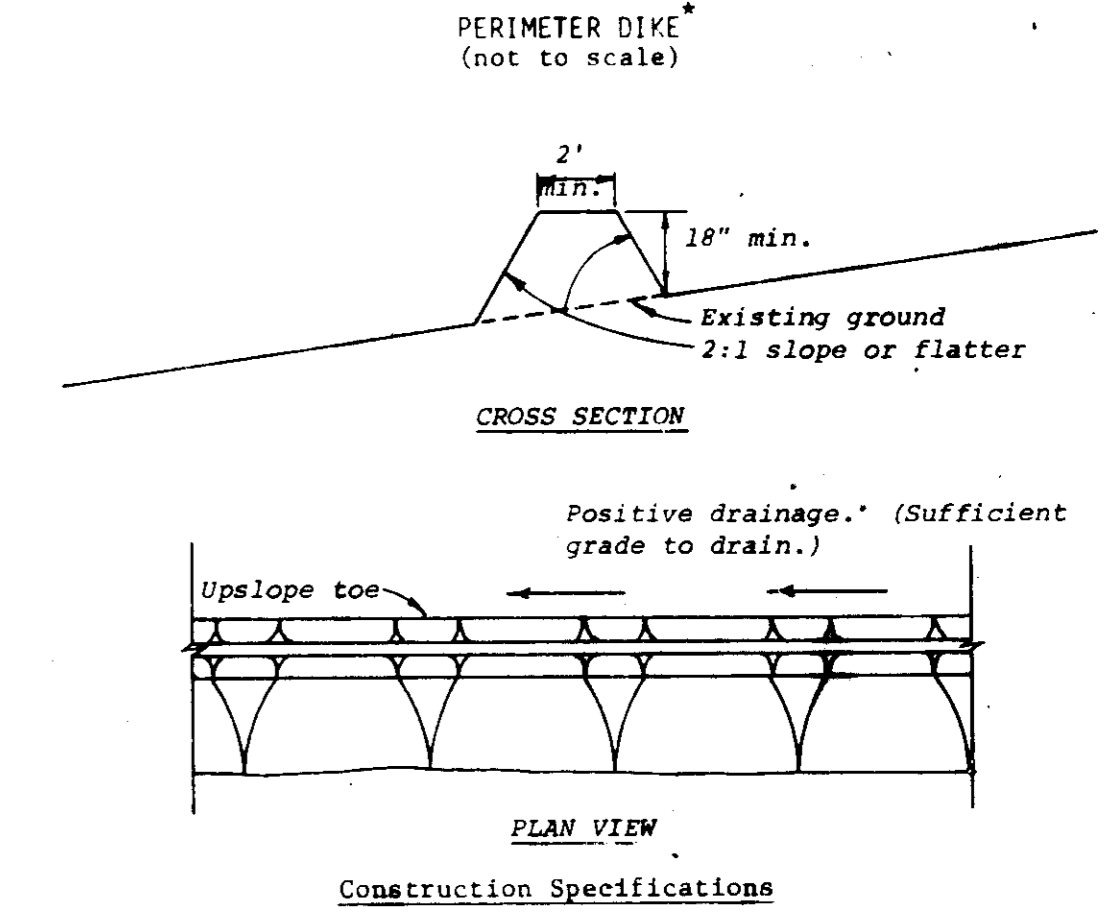

- Construction Specifications**
- All dikes shall be machine compacted.
 - All perimeter dikes shall have positive drainage to an outlet.
 - Diverted runoff from a protected or stabilized upland area shall outlet directly onto an undisturbed stabilized area or into a level spreader or grade stabilization structure.
 - Diverted runoff from a disturbed or exposed upland area shall be conveyed to a sediment trapping device such as sediment trap or a sediment basin or to an area protected by any of these practices.
 - Stabilization, when required, shall be done in accordance with Standard and Specifications for Grassed Waterway. The minimum area to be stabilized shall be the channel flow area.
 - Periodic inspection and required maintenance shall be provided.
- Standard Symbol:
- * Drainage area less than 5 acres

STABILIZED CONSTRUCTION ENTRANCE

- STONE SIZE - USE MSHA SIZE NO.2 (2-1/2" TO 1") OR AASHTO DESIGNATION M3 SIZE NO.2 (2-1/2" TO 1-1/2") USE CRUSHED STONE.
- LENGTH - AS EFFECTIVE, BUT NOT LESS THAN 50 FEET.
- THICKNESS - NOT LESS THAN EIGHT (8) INCHES.
- WIDTH - NOT LESS THAN FULL WIDTH OF PROPOSED PAVING.
- WASHING - WHEN NECESSARY, WHEELS SHALL BE CLEANED TO REMOVE SEDIMENT PRIOR TO ENTRANCE ONTO PUBLIC RIGHT-OF-WAY. WHEN WASHING IS REQUIRED, IT SHALL BE DONE ON AN AREA STABILIZED WITH CRUSHED STONE WHICH DRAINS INTO AN APPROVED SEDIMENT TRAP OR SEDIMENT BASIN. ALL SEDIMENT SHALL BE PREVENTED FROM ENTERING ANY STORM DRAIN, DITCH, OR WATER-COURSE THROUGH USE OF SAND BAGS, GRAVEL, OR OTHER APPROVED METHODS.
- MAINTENANCE - THE ENTRANCE SHALL BE MAINTAINED IN A CONDITION WHICH WILL PREVENT TRACKING OR FLOWING OF SEDIMENT ONTO PUBLIC RIGHT-OF-WAY. THIS MAY REQUIRE PERIODIC TOP DRESSING WITH ADDITIONAL STONE AS CONDITIONS DEMAND AND REPAIR AND/OR CLEAN OUT OF ANY MEASURES USED TO TRAP SEDIMENT. ALL SEDIMENT SPILLED, DROPPED, WASHED OR TRACKED ONTO PUBLIC RIGHT-OF-WAY MUST BE REMOVED IMMEDIATELY.

SEDIMENT TRAP DATA

DRAINAGE AREA	2.43 Ac.
DISTURBED AREA	1.28 Ac.
VOLUME REQUIRED	4400 CF
VOLUME AVAILABLE	4080 CF
RISE* CREST ELEVATION	432.00
CLEAROUT ELEVATION	431.82
Q INFLOW '0 YEAR	8.2 cfs
Q OUTFLOW '0 YEAR	7.5 cfs
10 YEAR PEAK ELEVATION	432.50

* RISE IS CIRCULAR WIER IN THE TOP OF THE STRUCTURE

SITE ANALYSIS

Total Impervious Surface within trap drainage area	1.46 Ac.
Proposed Impervious Surface	0.64 Ac.
Revegetated Area	0.64 Ac.

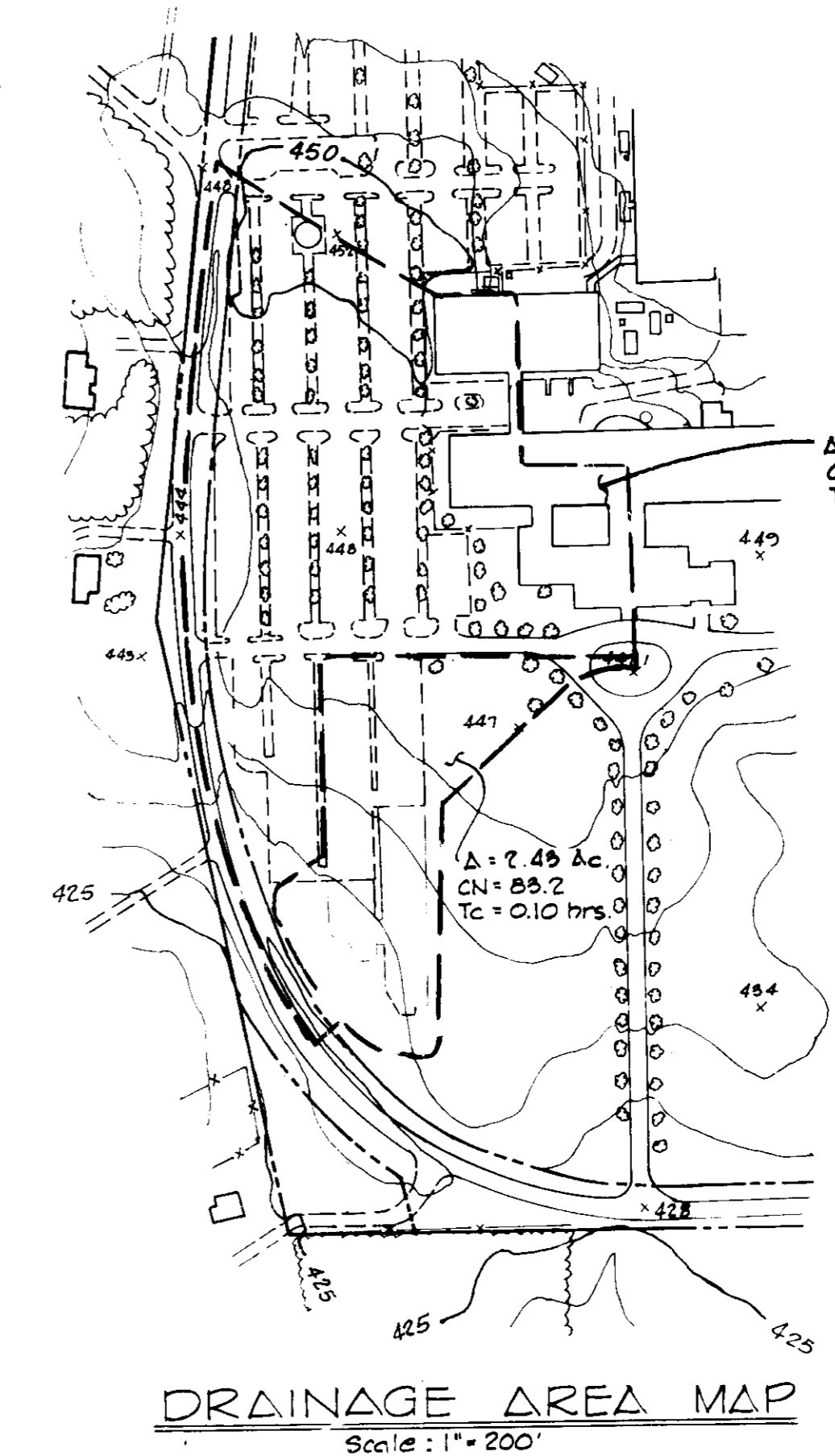

APPROVED
DIVISION OF LAND DEVELOPMENT & ZONING ADMINISTRATION
HOWARD COUNTY, MARYLAND
DATE 10-13-82

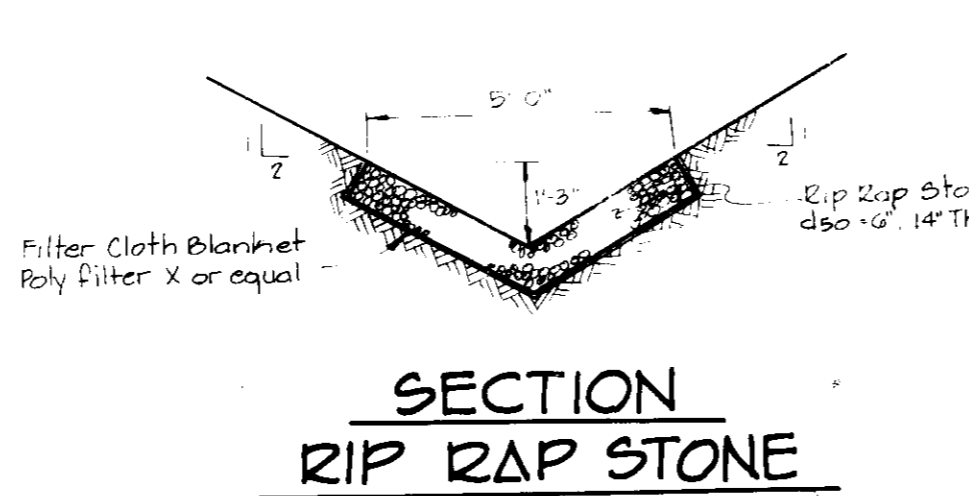
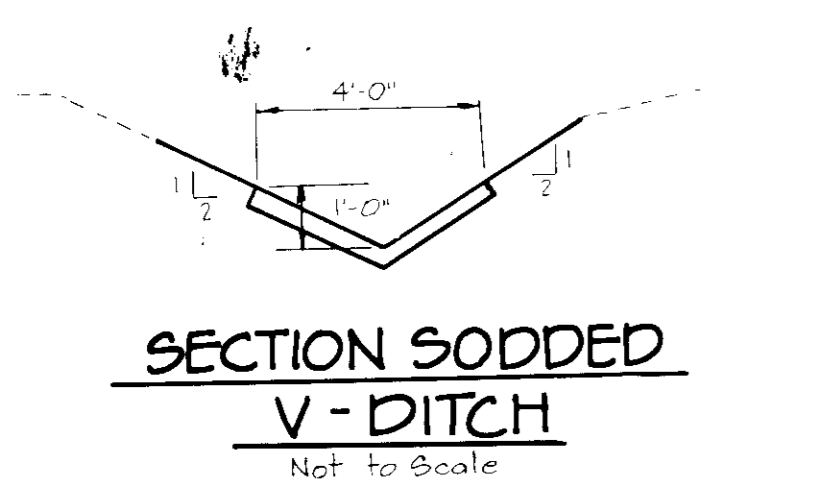

These plans have been reviewed for the Howard Soil Conservation District and meet the technical requirements for soil erosion and sediment control.
Signature: *[Signature]* DATE: 10-27-82
U.S. SOIL CONSERVATION SERVICE

These plans for soil erosion and sediment control meet the requirements of the Howard Soil Conservation District.
Signature: *[Signature]* DATE: 10-25-82
HOWARD S.C.D.

RESPONSIBLE PERSONNEL CERTIFICATION
"I HEREBY CERTIFY THAT ANY RESPONSIBLE PERSONNEL INVOLVED IN THE CONSTRUCTION PROJECT WILL HAVE A CERTIFICATE OF ATTENDANCE FROM A DEPARTMENT OF NATURAL RESOURCES APPROVED TRAINING PROGRAM FOR THE CONTROL OF SEDIMENT AND EROSION BEFORE BEGINNING THE PROJECT."
Signature: *[Signature]* DATE: 8/30/82
SIGNATURE OF DEVELOPER

CERTIFICATION BY THE DEVELOPER
"I certify that all development and or construction will be done according to this plan of development and plan for erosion and sediment control, and I also authorize periodic on-site inspection by the Howard Soil Conservation District or their authorized agents, as deemed necessary."
Signature: *[Signature]* DATE: 8/30/82
SIGNATURE OF DEVELOPER

CERTIFICATION BY THE ENGINEER
"I certify that this plan for erosion and sediment control represents a practical and workable plan based on my personal knowledge of the site conditions and that it was prepared in accordance with the requirements of the Howard Soil Conservation District."
Signature: *[Signature]* DATE: 8/30/82
KENNETH A. MCCORD, P.E. #1974

Note: Building Addition to SDP B2-116
Approved: For Private Water And Private Sewerage Systems, Howard County Health Department.
Signature: *[Signature]* DATE: 11-4-82
County Health Officer
Approved: Storm Drainage Systems And Roads, Howard County Department Of Public Works.
Signature: *[Signature]* DATE: 11-1-82
Director
Signature: *[Signature]* DATE: 10-29-82
Chief, Bureau Of Engineering
Approved: Howard County Office Of Planning And Zoning
Signature: *[Signature]* DATE: 11-5-82
Planning Director
Signature: *[Signature]* DATE: 11-5-82
Chief, Division Of Land Development And Zoning Administration

WHITMAN, REQUARDT AND ASSOCIATES
2315 SAINT PAUL STREET
BALTIMORE, MARYLAND
21218

APPLIED PHYSICS LABORATORY
THE JOHNS HOPKINS UNIVERSITY
Johns Hopkins Road, Howard County, Maryland
Approved For The University By: *[Signature]*
Date: 8/30/82 Title: Plant Eng.

VISITOR'S PARKING LOT EXPANSION
THE JOHNS HOPKINS UNIVERSITY APPLIED PHYSICS LABORATORY
1100 Johns Hopkins Road
Laurel, Maryland 20707

REVISIONS

SCALE: AS SHOWN
DRAWING SHEET NO. 3 OF 3
DATE: 8/1/82
DRAWING 3