

LEGEND

- EXISTING SPOT ELEVATION +348.81
- PROPOSED GRADE SPOT ELEVATION +50.04
- EXISTING STREAM
- EXISTING STRUCTURE
- NEW CONCRETE
- HANDRAIL
- EXISTING CONCRETE
- EXISTING PAVEMENT TO BE REMOVED
- SOILS CLASSIFICATION Mo.D
- SOILS DELINEATION
- LANDSCAPE TREE
- RETAINING WALL
- DOLLARD
- REMOVABLE DOLLARD

HUBBLE / KAISER
PARCEL B-1
PLAT No. 18699
ZONED B-2

N\F
HUBBLE SUBDIVISION
PB 6 PAGE 8 PARCEL 157
ZONED B-2
17490/0373
3146 ROGERS AVENUE LLC

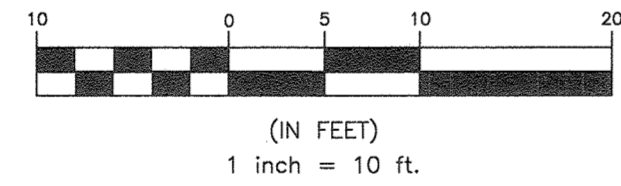

APPROVED: HOWARD COUNTY DEPARTMENT OF PLANNING AND ZONING

[Signature] 1-3-20
CHIEF, DEVELOPMENT ENGINEERING DIVISION DATE

[Signature] 1/3/20
CHIEF, DIVISION OF LAND DEVELOPMENT DATE

[Signature] 1-3-20
DIRECTOR DATE

SITE ANALYSIS DATA CHART

A.) TOTAL PROJECT AREA	0.70 AC. ±
B.) AREA OF PLAN SUBMISSION	0.10 AC. ±
C.) LIMIT OR DISTURBED AREA	0.10 AC. ±
D.) PRESENT ZONING	B-2
E.) PROPOSED USE OF SITE	COMPOUNDING PHARMACY
F.) FLOOR SPACE ON EACH LEVEL OF BLDG PER USE	1,356 SQ. FT.
G.) TOTAL NUMBER OF UNITS ALLOWED AS SHOWN ON FINAL PLAT(S)	N/A
H.) TOTAL NUMBER OF UNITS PROPOSED	N/A
I.) MAXIMUM NUMBER OF EMPLOYEES, TENANTS ON SITE PER USE	7
J.) NUMBER OF PARKING SPACES REQUIRED	9
K.) NUMBER OF PARKING SPACES PROVIDED	9
L.) OPEN SPACE ON-SITE	N/A
M.) AREA OF RECREATIONAL OPEN SPACE REQUIRED, AREA OF RECREATIONAL OPEN SPACE PROVIDED	N/A
N.) BUILDING COVERAGE OR SITE PERCENTAGE OF GROSS AREA	1,356 SQ. FT. 4%
O.) APPLICABLE DP2 FILE REFERENCES	F-06-047, WP-20-043

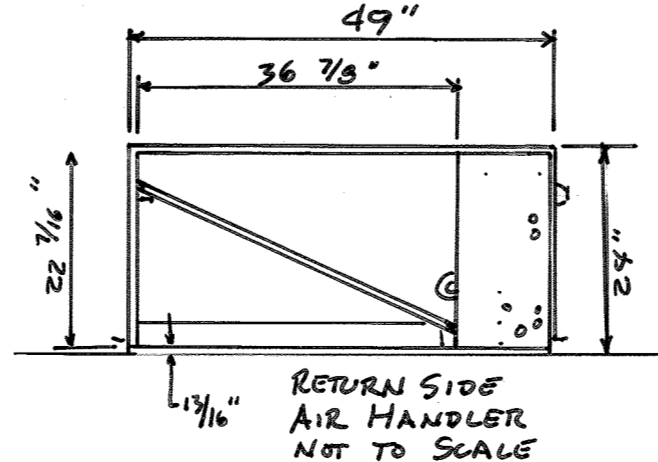
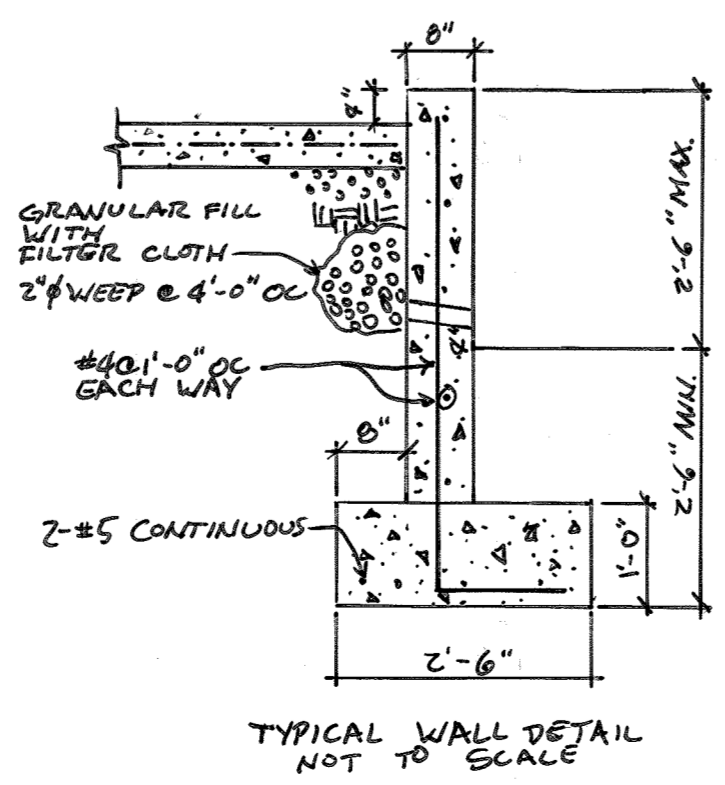

- GENERAL NOTES:**
- ALL CONSTRUCTION SHALL BE IN ACCORDANCE WITH THE LATEST STANDARDS AND SPECIFICATIONS OF HOWARD COUNTY PLUS MSHA STANDARDS AND SPECIFICATIONS IF APPLICABLE.
 - THE CONTRACTOR SHALL NOTIFY THE DEPARTMENT OF PUBLIC WORKS/BUREAU OF ENGINEERING/CONSTRUCTION INSPECTION DIVISION AT 410-313-1880 AT LEAST FIVE (5) WORKING DAYS PRIOR TO THE START OF WORK.
 - THE CONTRACTOR SHALL NOTIFY MISS UTILITY AT 1-800-257-7777 AT LEAST 48 HOURS PRIOR TO ANY EXCAVATION WORK.
 - ALL TRAFFIC CONTROL DEVICES AND THEIR LOCATIONS SHALL BE IN ACCORDANCE WITH THE LATEST EDITION OF THE MARYLAND MANUAL ON UNIFORM TRAFFIC CONTROL DEVICES (MUMUTCD).
 - ALL STREET AND REGULATORY SIGNS SHALL BE IN PLACE PRIOR TO THE PLACEMENT OF ANY ASPHALT.
 - ALL PLAN DIMENSIONS ARE TO FACE OF CURB UNLESS OTHERWISE NOTED.
 - ANY DAMAGE TO PUBLIC RIGHTS-OF-WAY, PAVING, OR EXISTING UTILITIES SHALL BE CORRECTED IMMEDIATELY AT THE CONTRACTOR'S EXPENSE.
 - WATER IS PUBLIC, CONTRACT #W-9.
 - SEWER IS PUBLIC, CONTRACT #10-1129.
 - STORMWATER MANAGEMENT DEVICES ARE COMPRISED OF ONE DRY WELL (M-5) SYSTEM THAT IS OWNED, OPERATED, AND MAINTAINED PRIVATELY.
 - EXISTING UTILITIES ARE LOCATED BASED ON THE AVAILABLE AS-BUILT DRAWINGS. THE CONTRACTOR SHALL FIELD VERIFY THE EXACT LOCATIONS OF EXISTING UTILITIES PRIOR TO ANY EXCAVATION. CONTRACTOR IS TO ADJUST ANY STRUCTURE ELEVATION THAT NEED TO BE ADJUSTED. CONTRACTOR IS TO REPLACE OR FORTIFY ANY STRUCTURE THAT NEED TO BE MADE TO BE TRAFFIC BEARING.
 - SOIL COMPACTION SPECIFICATIONS, REQUIREMENTS, METHODS AND MATERIALS ARE TO BE DETERMINED AND APPROVED BY LICENSED GEOTECHNICAL ENGINEER.
 - THE BEARINGS AND COORDINATES SHOWN HEREON ARE REFERENCED TO THE SYSTEM OF COORDINATES ESTABLISHED IN THE MARYLAND STATE COORDINATE SYSTEM (NAD 83/11) AS SHOWN ON PLAT M.D.B. #18699.
 - CONTOURS AND ELEVATIONS SHOWN HEREON ARE REFERENCED TO THE NORTH AMERICAN VERTICAL DATUM 1988 (NAVD 88) WITH LOCAL REFERENCE TO THE FOLLOWING HOWARD COUNTY GEODETIC SURVEY CONTROL STATIONS 24C2 AND 1861 PER THE RECORD PLAT.
 - THE COORDINATES SHOWN HEREON ARE BASED UPON THE HOWARD COUNTY GEODETIC CONTROL WHICH IS BASED UPON THE MARYLAND STATE PLANE COORDINATE SYSTEM, HOWARD COUNTY MONUMENTS NOS. 24C2 AND 1861 WERE USED FOR THIS PROJECT.
 - THE PROPERTY IS NOT LOCATED WITHIN 100-YEAR FLOOD ZONE.
 - ALL EXTERIOR LIGHT FIXTURES SHALL BE ORIENTED TO DIRECT LIGHT INWARDS AND DOWNWARDS ON-SITE, AWAY FROM ALL ADJOINING RESIDENTIAL PROPERTIES AND PUBLIC ROADS IN ACCORDANCE WITH SECTION 134 OF THE HOWARD COUNTY ZONING REGULATIONS.
 - THE SUBJECT PROPERTY IS ZONED B-2 PER THE OCTOBER 6, 2013 COMPREHENSIVE ZONING PLAN.
 - NO GRADING, REMOVAL OF VEGETATIVE COVER OR TREES, PAVING AND NEW STRUCTURES SHALL BE PERMITTED WITHIN WETLANDS, STREAM BUFFERS, FOREST CONSERVATION EASEMENT AND 100-YEAR FLOOD PLAIN EXCEPT AS APPROVED BY THE ALTERNATIVE COMPLIANCE.
 - FOREST CONSERVATION OBLIGATION FOR THIS DEVELOPMENT IS NOT REQUIRED. THE PROJECT IS EXEMPT BECAUSE THE PROPERTY IS LESS THAN 40,000 SF IN SIZE.
 - THE EXISTING TOPOGRAPHY IS TAKEN FROM HOWARD COUNTY GIS DATA AND SUPPLEMENTED WITH FIELD SURVEY INFORMATION FROM BENCHMARK ENGINEERING, INC., DATED SEPTEMBER, 2019.
 - LANDSCAPING IS PROVIDED WITH A CERTIFIED LANDSCAPE PLAN IN ACCORDANCE WITH SECTION 16.124 OF THE HOWARD COUNTY CODE AND LANDSCAPE MANUAL. FINANCIAL POSTING OF SURETY FOR REQUIRED LANDSCAPING IN ACCORDANCE WITH SECTION 16.124 OF THE LANDSCAPE MANUAL IN THE AMOUNT OF \$300.00 FOR ONE (1) SHADE TREE. FINANCIAL SURETY FOR THE REQUIRED LANDSCAPING MUST BE POSTED AS PART OF THE GRADING PERMIT OR BUILDING PERMIT.
 - WP-20-043, A REQUEST TO WAIVE SECTIONS 16.155(a)(1), APPLICABILITY FOR NON-RESIDENTIAL SITE DEVELOPMENT PLAN, AND SECTION 16.116(A)(2)(v), PROTECTION OF STREAMBANKS IN NON-RESIDENTIAL DISTRICTS, HAS BEEN APPROVED BY THE DIRECTOR OF THE DEPARTMENT OF PLANNING AND ZONING ON JANUARY 16, 2020. SEE THE ALTERNATIVE COMPLIANCE, WP-20-043, FOR CONDITIONS OF APPROVAL AND APPROVED LIMITS OF DISTURBANCE WITHIN THE STREAM BUFFER.
 - APPLICABLE HOWARD COUNTY PREVIOUS FILE NUMBERS: F-06-047, WP-20-043
 - ALL TRAFFIC CONTROL DEVICES AND THEIR LOCATIONS SHALL BE IN ACCORDANCE WITH THE LATEST EDITION OF THE MARYLAND MANUAL ON UNIFORM TRAFFIC CONTROL DEVICES (MUMUTCD).
 - RETAINING WALLS ARE LESS THAN 5.0' AT ALL LOCATIONS AND EXEMPT FROM DEVELOPMENT ENGINEERING DIVISION REVIEW PER DESIGN MANUAL VOL III, ROADS AND BRIDGES, SECTION 3.4.A.3.a.
 - THE 0.0' OF 4.46 SF IS EXEMPT FROM PROVIDING STORMWATER MANAGEMENT. ANY ADDITIONAL CHANGES WHERE THE CUMULATIVE INCREASE SHALL REQUIRE THAT STORMWATER MANAGEMENT BE ADDRESSED.

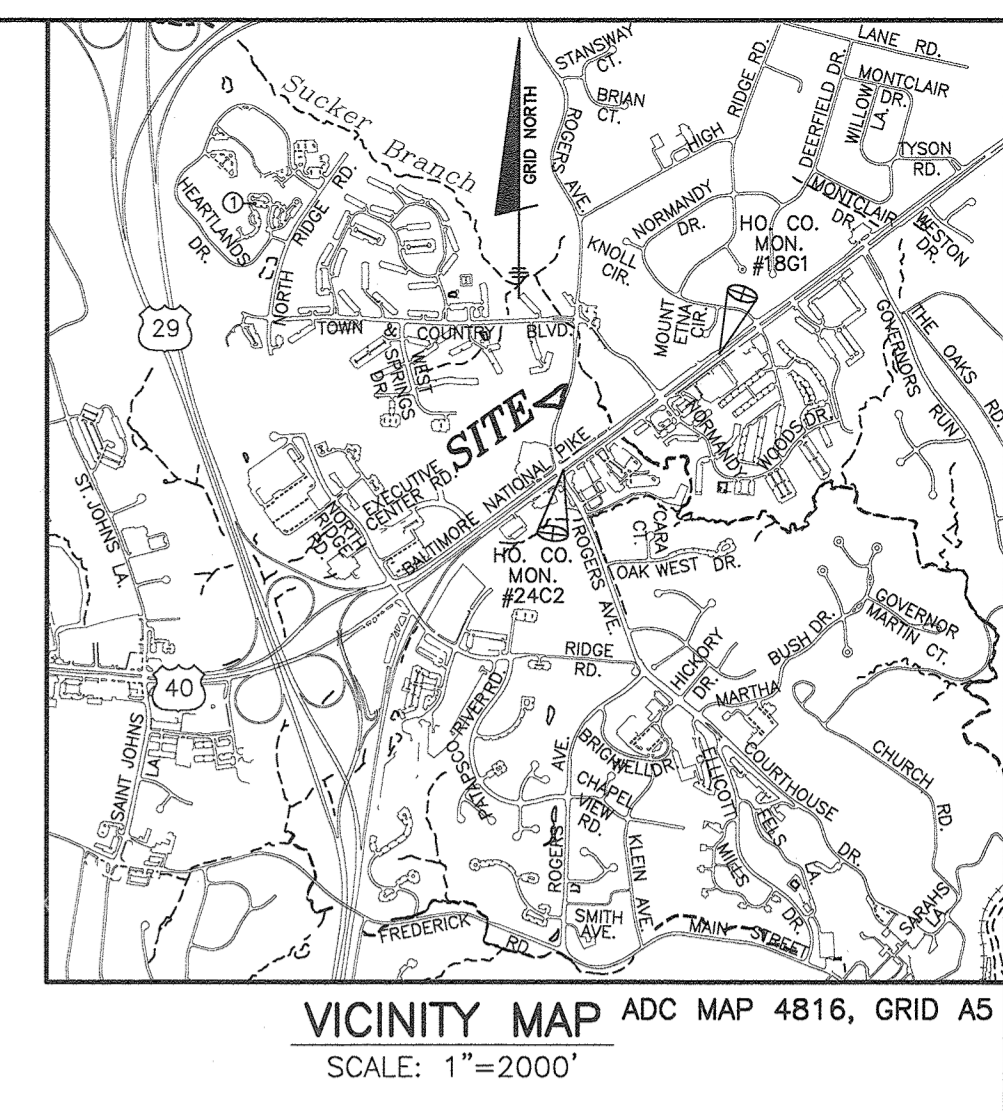

- SITE NOTES:**
- THE CONTRACTOR SHALL COORDINATE THE SEQUENCE OF CONSTRUCTION WITH THE DEVELOPER.
 - THE CONTRACTOR SHALL TAKE NOTE THAT ALL GRADES SHALL MAINTAIN A POSITIVE FLOW TO EXISTING INLETS, SWALES, DRAINAGE FACILITIES, ETC.
 - THE CONTRACTOR SHALL VISIT THE WORK SITE TO BECOME FAMILIAR WITH ALL LOCAL CONDITIONS AFFECTING THE WORK.
 - ALL CONSTRUCTION SHALL BE IN ACCORDANCE WITH O.S.H.A. & M.O.S.H.A. REQUIREMENTS.
 - ANY CHANGES FROM THE PLANS SHALL HAVE PRIOR WRITTEN APPROVAL BY THE DEVELOPER.
 - UNDERGROUND UTILITIES WILL BE ENCOUNTERED. EXISTING UTILITIES SHOWN ARE FOR INFORMATIONAL PURPOSES PRIOR TO BEGINNING ANY WORK. THE CONTRACTOR SHALL REVIEW ALL EXISTING PLANS, OBTAIN THE SERVICES OF AN UNDERGROUND UTILITY LOCATING COMPANY TO MARK UTILITIES AND VERIFY DEPTH BY TEST PITTING, HAVE MARKED UTILITIES SURVEYED AND PLACED ON DRAWINGS IN AUTOCAD USING MARYLAND STATE COORDINATE SYSTEM. THE CONTRACTOR ASSUMES FULL RESPONSIBILITY FOR THE REPAIR OF ANY UTILITIES DAMAGED DUE TO THESE CONSTRUCTION ACTIVITIES, AT NO ADDITIONAL COST TO THE DEVELOPER.
 - PRIOR TO ANY CONSTRUCTION/DIGGING, THE CONTRACTOR SHALL NECESSARY PERMITS AND LOCATE ALL UNDERGROUND UTILITIES.
 - ALL GROUND ADJACENT TO WALKS SHALL BE 1" LOWER THAN THE WALK. ALL GRADES SHALL MAINTAIN A POSITIVE FLOW AWAY FROM THE BUILDING.
 - THE EXISTING PORCH IS TO BECOME A LANDING AREA AND DOORWAY MANEUVERING AREA. THE EXISTING PORCH IS SLIGHTLY OVER 2.0% SLOPE. THE OWNER WISHES TO KEEP PORCH AS IS AND NOT MODIFY THE EXISTING SURFACE IF POSSIBLE. THIS IS A RETRO FIT CONDITION FOR THIS PORCH TO BE A ADA COMPLIANT ENTRANCE. THE EXPANSION OF THE PORCH AREA WILL CREATE A CLEAR AREA IN ACCORDANCE WITH ADA LENGTH AND WIDTH REQUIREMENTS. NEW CONCRETE WILL COMPLY WITH THE SLOPE REQUIREMENTS FOR A LANDING AREA FOR SLOPE.
 - THIS SITE IS NOT WITHIN THE TIBER/HUDSON OR THE PLUMTREE DRAINAGE AREAS.
- SIGNING AND STRIPING NOTES:**
- ALL SIGNING AND STRIPING SHALL BE IN ACCORDANCE WITH THE MARYLAND STATE HIGHWAY ADMINISTRATION STANDARD DETAILS AND SPECIFICATIONS, THE MANUAL ON UNIFORM TRAFFIC CONTROL DEVICES, THE MARYLAND MANUAL ON TRAFFIC CONTROL DEVICES, THE MARYLAND SIGN MANUAL AND HOWARD COUNTY STANDARDS AND SPECIFICATIONS.
 - ALL MOUNTING AND POST SUPPORT SHALL MEET THE REQUIREMENTS OF THE ABOVE IN 1.
 - THE CONTRACTOR SHALL SCALE LOCATION OF ALL STRIPING AND SIGNING FROM THE PLAN. THE CONTRACTOR SHALL VERIFY WITH THE DEVELOPER THE LOCATION OF ALL SIGNING AND STRIPING PRIOR TO INSTALLATION.
 - SIGNS SHALL BE MOUNTED ON POST EMBEDDED IN CONCRETE (SEE DETAIL).

SHEET INDEX

NUMBER	DESCRIPTION
1	ALTERNATIVE COMPLIANCE EXHIBIT COVER SHEET
2	ALTERNATIVE COMPLIANCE EXHIBIT ADA ACCESSIBILITY PLAN
3	ALTERNATIVE COMPLIANCE EXHIBIT PARKING LOT
3	MANEUVERING ABILITY EXHIBIT, SOILS MAP, LANDSCAPE AND SWM PLAN

ADDRESS CHART

PARCEL NO.	STREET ADDRESS
A	3138 ROGERS AVENUE

PERMIT INFORMATION CHART

SUBDIVISION NAME	SECTION/AREA	PARCEL #
MAIER INDUSTRIAL PARK		B (P/O 436)

PLAT CMP #	BLOCK NO.	ZONE	TAX MAP NO.	ELECTION DISTRICT
18699	24	B-2	17	2

NO.	DATE	REVISION
1	6-2-2020	ADD AIR HANDLERS AND COMPENSER UNITS, CLEAR AREAS, PAVS AND WALLS

Professional Certification I hereby certify that these documents were prepared or approved by me, and that I am a duly licensed professional engineer under the laws of the State of Maryland, License No. 45577, Expiration Date: 06-08-2020.

BENCHMARK ENGINEERS & LAND SURVEYORS & PLANNERS
8480 BALTIMORE NATIONAL PIKE & SUITE 315 • ELLICOTT CITY, MARYLAND 21043
(P) 410-468-9108 (F) 410-468-8144
WWW.BEI-CVLENGINEERING.COM

[Signature] 12/31/19

OWNER/DEVELOPER: EMPIRE LLC
C/O PROFESSIONAL ARTS PHARMACY
2015 LORD BALTIMORE DR
WOODLAWN, MD 21244
443-200-1200

HUBBLE / KAISER PARCEL A
PLAT NUMBER 18699

TAX MAP: 17 GRID: 24 PARCEL: 436
ZONED: B-2
3138 ROGERS AVENUE
ELLICOTT CITY, MD 21043
ELECTION DISTRICT NO. 2 HOWARD COUNTY, MARYLAND

ALTERNATIVE COMPLIANCE EXHIBIT COVER SHEET

DATE: DEC. 31, 2019 BEI PROJECT NO. 2972

DESIGN: JC DRAFT: JC SCALE: 1" = 10' SHEET 1 OF 3

HUBBLE / KAISER
PARCEL 'B-1'
PLAT No. 18699
ZONED B-2

LEGEND

EXISTING SPOT ELEVATION	+ 348.81
PROPOSED GRADE SPOT ELEVATION	+ 50.04
EXISTING STREAM	
EXISTING STRUCTURE	
NEW CONCRETE	
HANDRAIL	
EXISTING CONCRETE EDGE	
OFFSET OF RECENT IMPROVEMENTS 3,400 SF	
EXISTING PAVEMENT TO BE REMOVED	
SOILS CLASSIFICATION	MoD
SOILS DELINEATION	

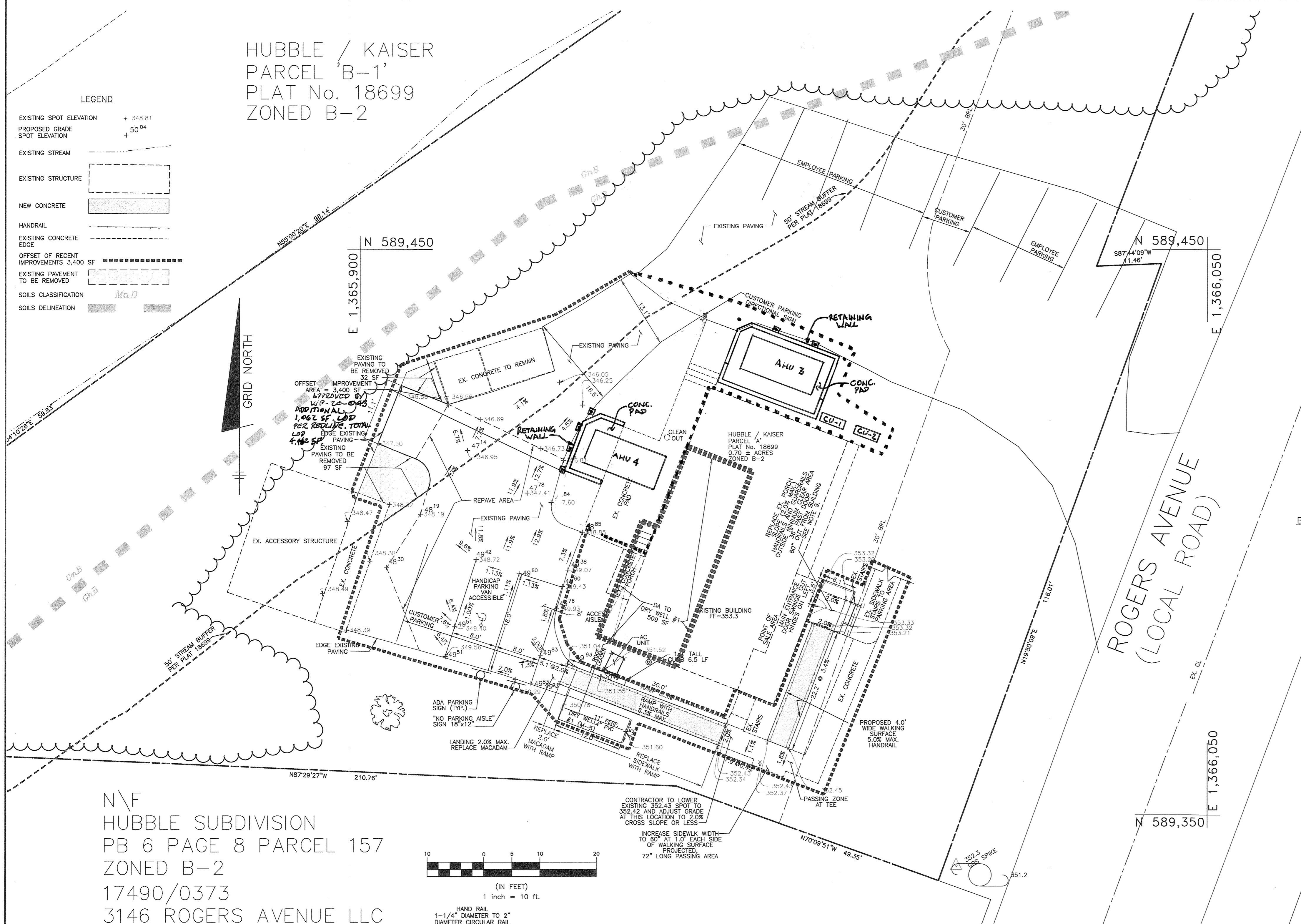

N\F
HUBBLE SUBDIVISION
PB 6 PAGE 8 PARCEL 157
ZONED B-2
17490/0373
3146 ROGERS AVENUE LLC

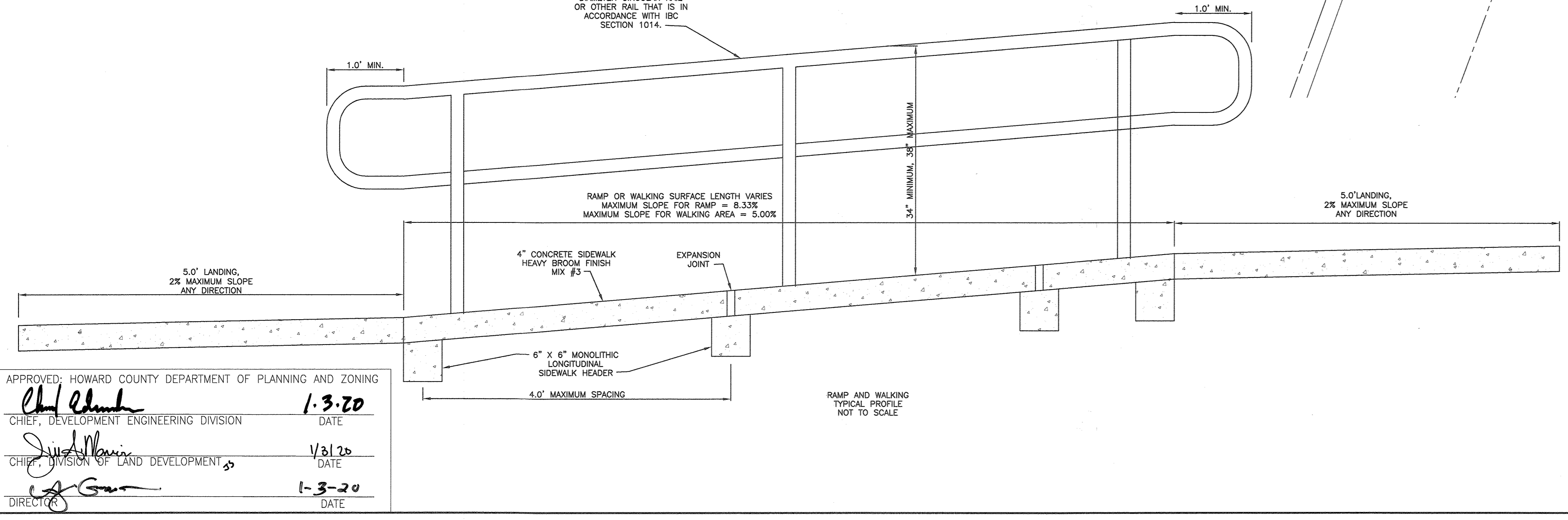
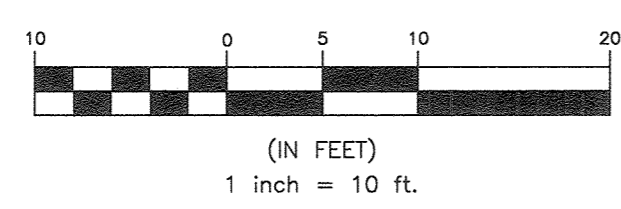

APPROVED: HOWARD COUNTY DEPARTMENT OF PLANNING AND ZONING

<i>[Signature]</i>	1-3-20
CHIEF, DEVELOPMENT ENGINEERING DIVISION	DATE
<i>[Signature]</i>	1/31/20
CHIEF, DIVISION OF LAND DEVELOPMENT	DATE
<i>[Signature]</i>	1-3-20
DIRECTOR	DATE

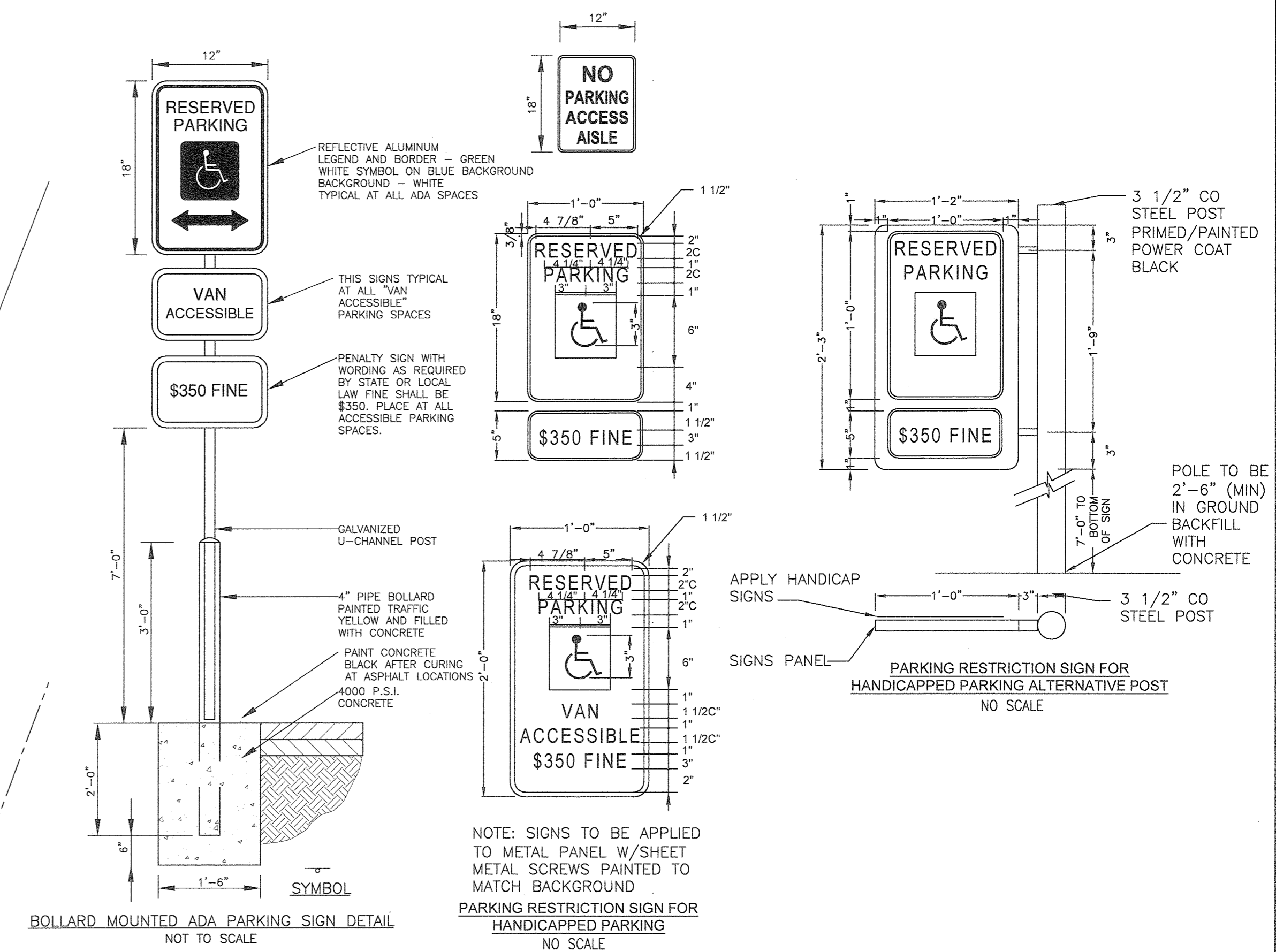

BOLLARD MOUNTED ADA PARKING SIGN DETAIL
NOT TO SCALE

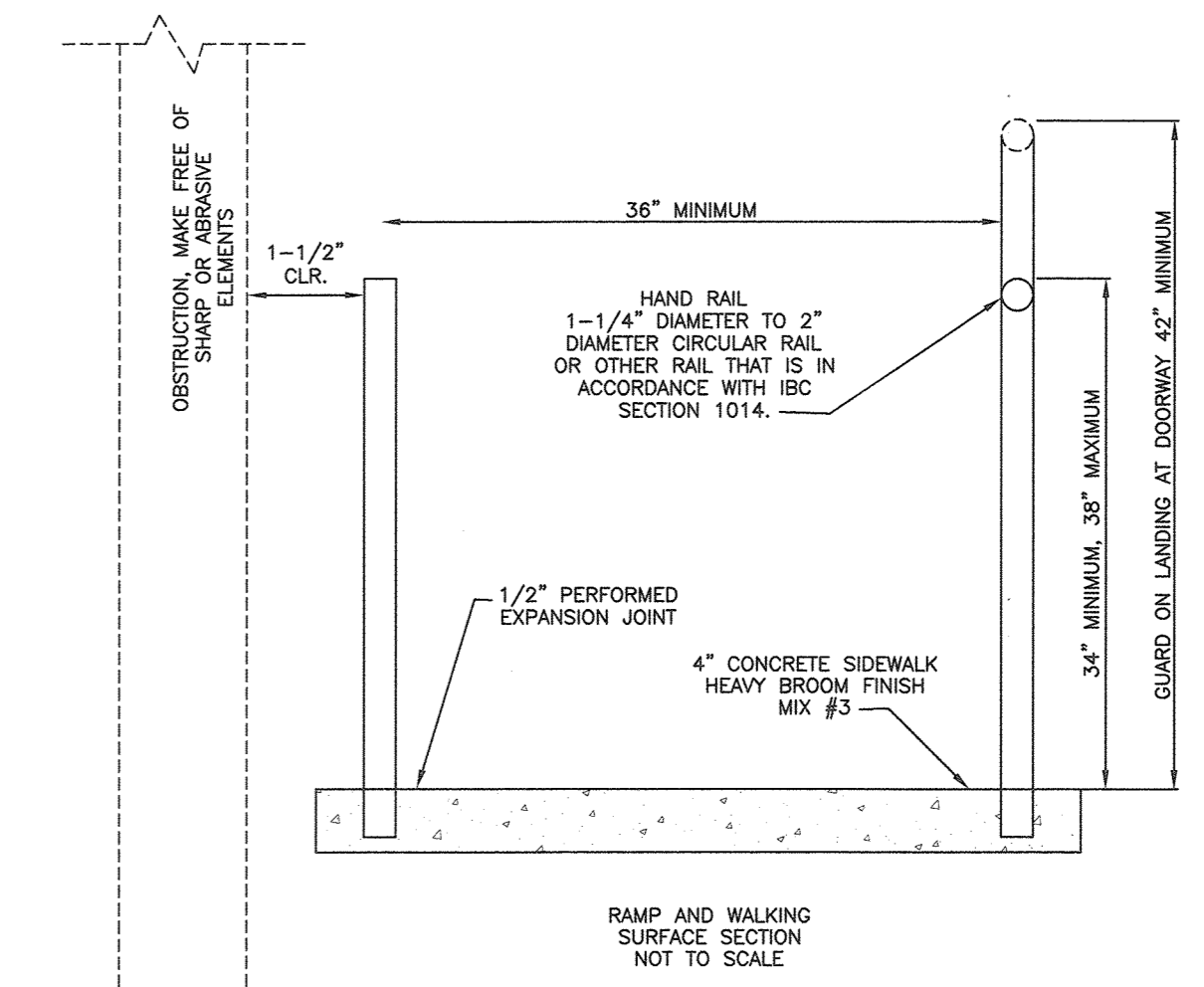

RAMP AND WALKING SURFACE SECTION
NOT TO SCALE

- NOTES:**
1. SIDEWALK TO BE SCRIBED IN 5'-0" MAXIMUM SQUARES.
 2. EXPANSION JOINTS ACROSS THE SIDEWALK NOT TO BE MORE THAN 15' APART, OF 16" FOR 4' WIDE SIDEWALK.
 3. * PREFORMED EXPANSION MATERIAL IN EXPANSION JOINTS TO BE KEPT 1/2" BELOW SURFACE OF SIDEWALK.
 4. CONCRETE TO BE MIX #3.
 5. ON LONGITUDINAL SIDEWALK GRADES OF 5% OR GREATER, A CONCRETE HEADER, 6" THICK AND 6" DEEP BELOW THE NORMAL 4" SIDEWALK THICKNESS SHALL BE CONSTRUCTED FOR THE FULL WIDTH OF THE SIDEWALK AT INTERVALS OF 48'. THE HEADERS SHALL BE PLACED AT THE EXPANSION JOINT LOCATIONS AND SHALL BE MONOLITHIC WITH THE SIDEWALK.
 6. SIDEWALK LOCATED 2' OR MORE FROM CURB MAY BE 4'-0" IN WIDTH WITH A 5'x5' PAVED SECTION PLACED 200' APART.
 7. 4'-0" SIDEWALK REQUIRES A PASSING AREA (SEE DETAIL R-4.1.1).
 8. RAMPS, WALKING SURFACES AND SIDEWALKS SHALL BE CONSTRUCTED SO THAT WATER WILL NOT ACCUMULATE ON THE SURFACES.

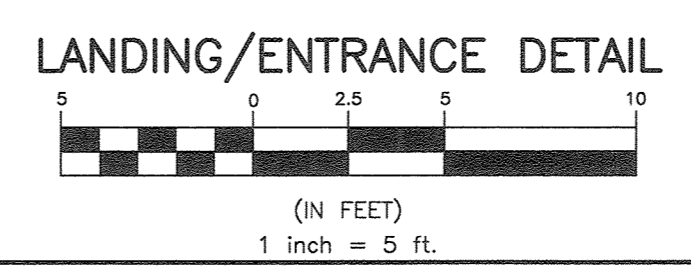
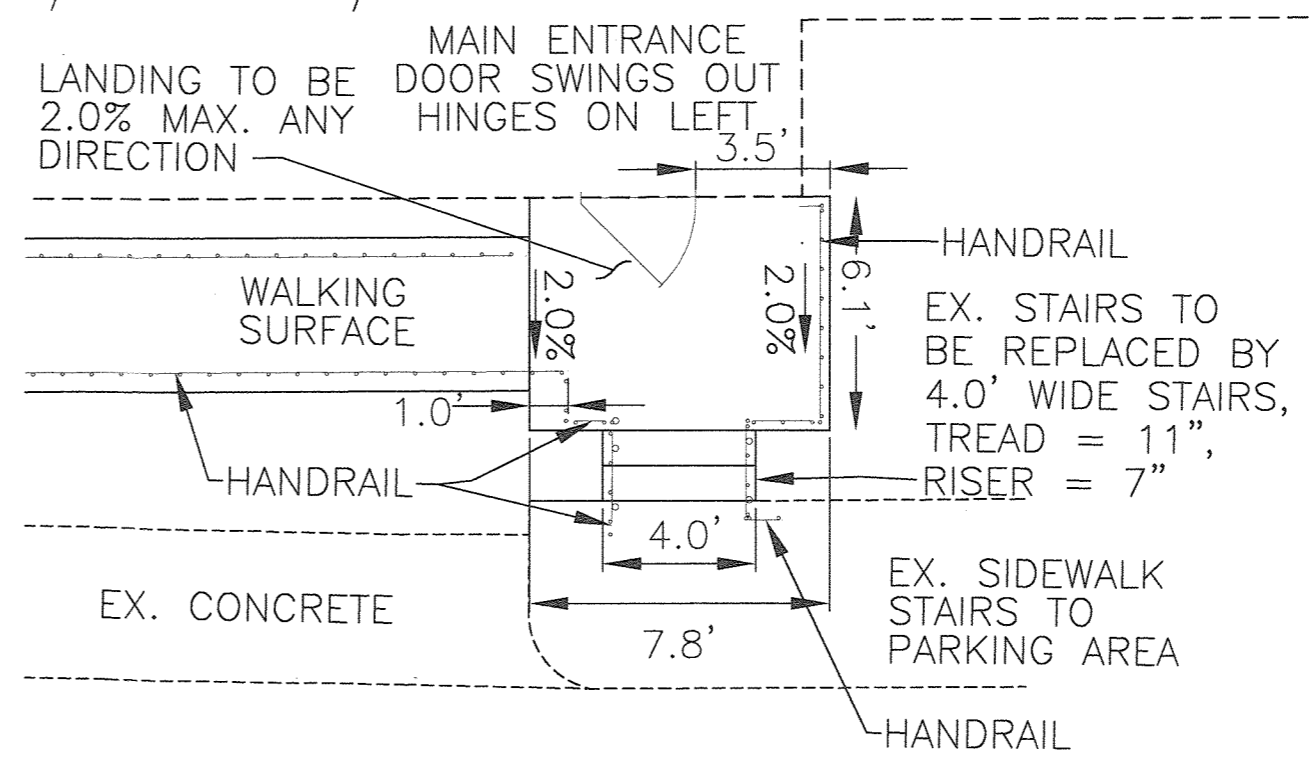

LANDING/ENTRANCE DETAIL

6-3-2020 ADD AIR HANDLER UNITS, CONDENSER UNITS AND WALLS REVISE L.O.D.		REVISION	
NO.	DATE		
<p>BENCHMARK ENGINEERS & LAND SURVEYORS & PLANNERS ENGINEERING, INC. 8480 BALTIMORE NATIONAL PIKE & SUITE 315 A ELLICOTT CITY, MARYLAND 21043 (P) 410-465-9108 (F) 410-465-6544 WWW.BEI-CVENGINEERS.COM</p>		<p>Professional Certification I hereby certify that these documents were prepared or approved by me, and that I am a duly licensed professional engineer under the laws of the State of Maryland, License No. 45577; Expiration Date: 06-68-2020.</p> <p><i>[Signature]</i> 12/31/19</p>	
OWNER/DEVELOPER:		HUBBLE / KAISER	
EMPIRE LLC C/O PROFESSIONAL ARTS PHARMACY 2015 LORD BALTIMORE DR WOODLAWN, MD 21244 443-200-1200		PARCEL A PLAT NUMBER 18699	
TAX MAP: 17 GRID: 24 PARCEL: 436 ZONED: B-2 3138 ROGERS AVENUE ELLICOTT CITY, MD 21043 ELECTION DISTRICT NO. 2 HOWARD COUNTY, MARYLAND		ALTERNATIVE COMPLIANCE EXHIBIT ADA ACCESSIBILITY PLAN	
DATE: DEC. 31, 2019	BEI PROJECT NO. 2972	DATE: DEC. 31, 2019	SHEET 2 OF 3
DESIGN: JC	DRAFT: JC	SCALE: 1" = 10'	SHEET 2 OF 3

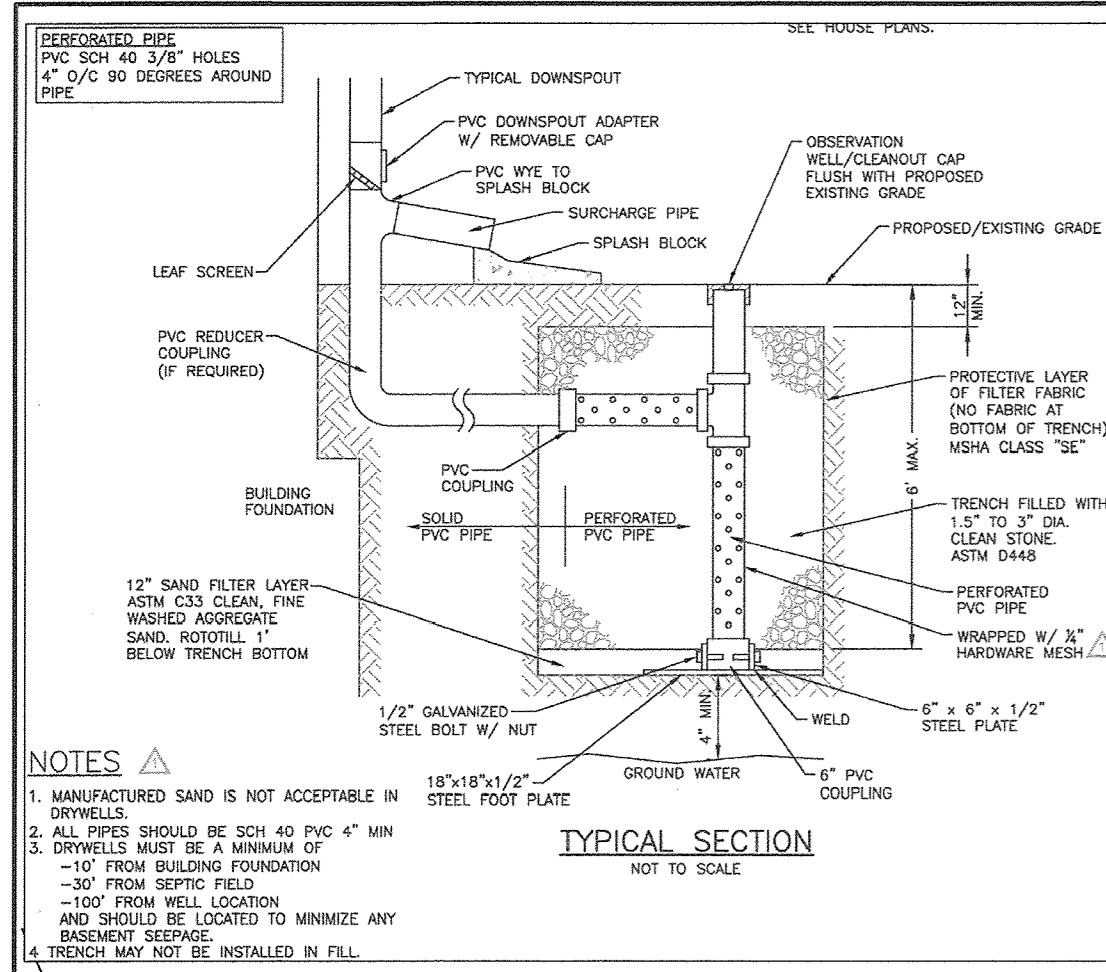

Facility	Drainage Area (SF)	Impervious Area (SF)	I (%)	Rv	ESDv (cf)	Length (ft)	Width (ft)	Depth (ft)	Porosity	Grade	Top of Stone	Bottom of Sand	Volume Stored (cf)	sq Treated
IN-1 (M-5)	509	509	100%	0.950	81	4.5	12.0	3.0	0.40	350.8	349.8	344.8	108	2.68
TOTALS		509											108	

The total ESDv provided by this design is: 108 CF
 The total Rv provided by this design is: 104 CF
 *The ESDv summary table potrays storage in excess of that required for Environmental Site Design requirements.

OPERATION AND MAINTENANCE SCHEDULE FOR PRIVATELY OWNED AND MAINTAINED (M-5) DRYWELLS

- The monitoring wells and structures shall be inspected on a quarterly basis and after every large storm event.
- Water levels and sediment build up in the monitoring wells shall be recorded over a period of several days to insure trench drainage.
- A log book shall be maintained to determine the rate at which the facility drains.
- When the facility becomes clogged so that it does not drain down within the 72 hour time period, corrective action shall be taken.
- The maintenance log book shall be available to Howard County for inspection to insure compliance with operation and maintenance criteria.
- Once the performance characteristics of the infiltration facility have been verified, the monitoring schedule can be reduced to an annual basis unless the performance data indicates that a more frequent schedule is required.

- NOTES**
- MANUFACTURED SAND IS NOT ACCEPTABLE IN DRYWELLS.
 - ALL PIPES SHOULD BE SCH 40 PVC 4" MIN.
 - DRIVEWELLS MUST BE A MINIMUM OF 10" FROM BUILDING FOUNDATION AND 100' FROM SEPTIC FIELD AND SHOULD BE LOCATED TO MINIMIZE ANY BASEMENT SEWAGE TRENCHING.
 - TRENCHING MAY NOT BE INSTALLED IN FLL.

(M-5) Drywell #1

Pro Arts

DA = 509sf ok Check
 Imp = 509sf Impervious ok Check
 I = 100% Percent Impervious ok Check
 PE target = 2.6 Rainfall in Inches req. ok Check
 ESDv = 105 CF Storage Req'd ok Check
 d₁ = 5.0 ft Filter Depth ok Check
 r = 40% Porosity ok Check

R_v = 0.95 Runoff Coefficient
 HSG = B

Area(f) = 54 sq. ft.
 Actual_v = 108 CF Storage Prov'd
 Storage = 103% ok Check

Section

Length = 4.5 ft
 Width = 12.0 ft

Ground Elevation = 350.80
 Top of Storage Vol = 349.80

Filter Media Bottom/
 Top of Sand layer = 345.80
 Facility Bottom = 344.80

HUBBLE / KAISER
 PARCEL 'B-1'
 PLAT No. 18699
 ZONED B-2

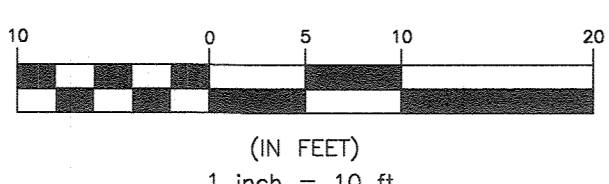
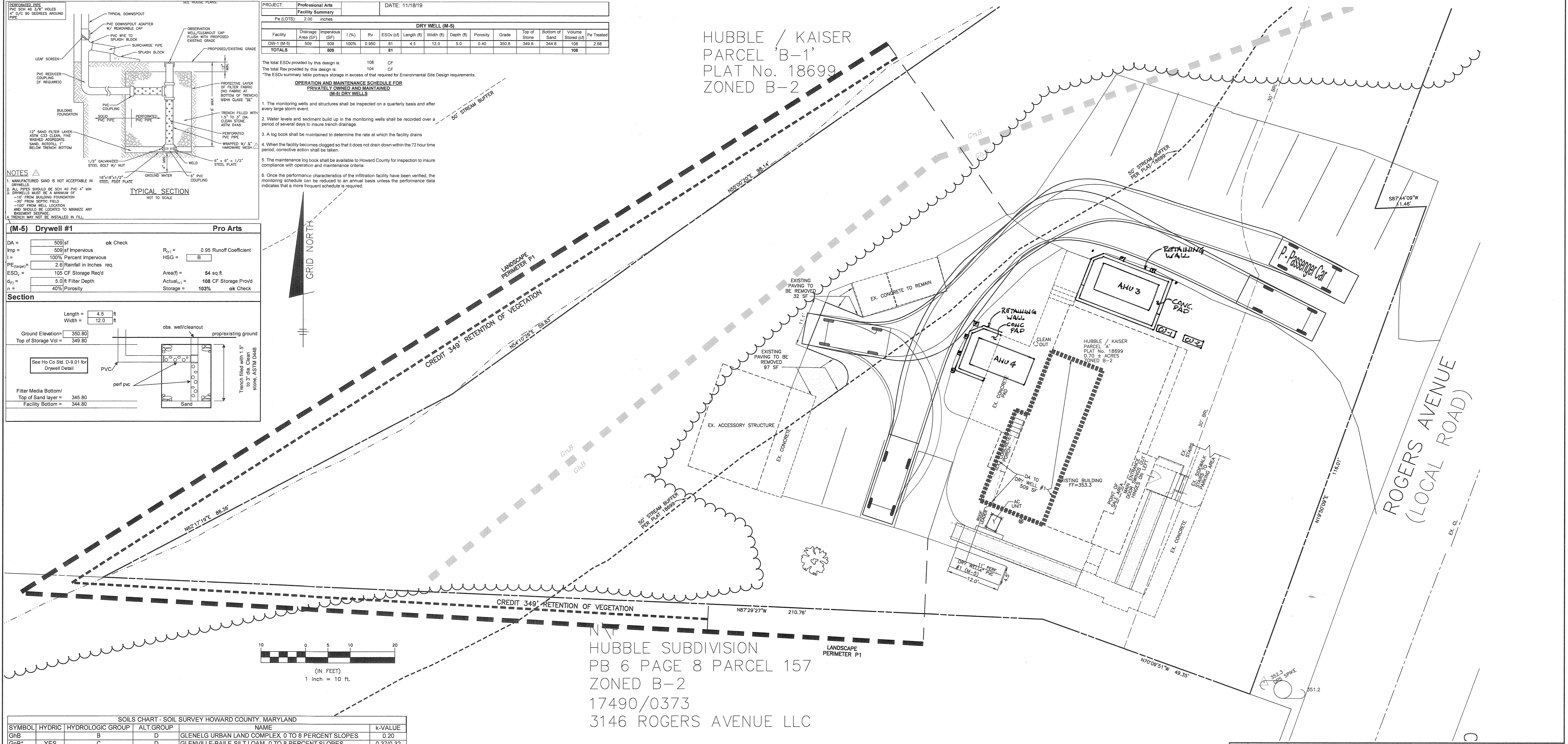

HUBBLE SUBDIVISION
 PB 6 PAGE 8 PARCEL 157
 ZONED B-2
 17490/0373
 3146 ROGERS AVENUE LLC

SYMBOL	HYDRIC	HYDROLOGIC GROUP	ALT. GROUP	NAME	K-VALUE
GnB		B	D	GLENELG URBAN LAND COMPLEX, 0 TO 8 PERCENT SLOPES	0.20
GnB*	YES	C	D	GLENNVILLE-BAILE SILT LOAM, 0 TO 8 PERCENT SLOPES	0.37/0.32

HGHLY ERODIBLE SILS ON SITE.
 HGHLY ERODIBLE SOILS: k>0.35 AND >5% SLOPES, OR SOILS >15% SLOPES.

SYMBOL	QUANTITY	NAME	REMARKS	DESCRIPTION
	1	Acer rubrum October Glory (October Glory Red Maple)	2.5" - 3" cal.	TO BE PLANTED ALONG THE LOT PERIMETERS (PROVIDED BY THE DEVELOPER)

DESIGNATION	ADJACENT TO PERIMETER PROPERTIES	TOTAL
LANDSCAPE TYPE (A, B, C, D OR E)	A	
LINEAR FEET OF PERIMETER OR ROADWAY FRONTAGE	397	397
CREDIT FOR EXISTING VEGETATION (YES, NO, LINEAR FEET)	YES	349
CREDIT FOR WALL, FENCE OR BERM (YES, NO, LINEAR FEET)	NO	0
NUMBER OF PLANTS REQUIRED		
SHADE TREES	1	1
EVERGREEN TREES	0	0
SHRUBS	0	0
NUMBER OF PLANTS PROVIDED		
SHADE TREES	1	1
EVERGREEN TREES	0	0
SHRUBS	0	0
OTHER TREES (2:1 SUB.)	0	0
SHRUBS (10:1 SUB.)	0	0
DESCRIBE SUBSTITUTION	NA	
CORRECT NUMBER PROVIDED	TRUE	

LANDSCAPING NOTES

- THE PROPOSED LANDSCAPING SHALL BE PROVIDED BY THE PLANTINGS AS SHOWN ON THESE PLANS.
- THE DEVELOPER SHALL BE RESPONSIBLE FOR ALL INTERNAL PLANTINGS.
- A MINIMUM DISTANCE OF TWENTY (20) FEET MUST BE MAINTAINED BETWEEN ANY TREES LOCATED ALONG THE CURB LINE AND FROM STREET LIGHTS.
- TREES MUST BE PLANTED A MINIMUM OF FIVE (5) FEET FROM AN OPEN SPACE ACCESS STRIP, TEN (10) FEET FROM A DRIVEWAY AND FIVE (5) FEET FROM A STORM DRAIN.
- THIS PLAN HAS BEEN PREPARED IN ACCORDANCE WITH THE PROVISIONS OF SECTION 16.124 OF THE HOWARD COUNTY CODE AND LANDSCAPE MANUAL.
- ALL LANDSCAPING PLANT TYPES SHOWN ON THESE PLANS ARE RECOMMENDATIONS AND MAY BE SUBSTITUTED WITH APPROVED EQUIVALENTS FROM THE HOWARD COUNTY LANDSCAPE MANUAL.
- NO TREES SHALL BE PLACED WITHIN 10' BEHIND A RETAINING WALL OR WITHIN A RELATED MAINTENANCE EASEMENT, WHICHEVER IS GREATER.
- POSTING OF SURETY FOR REQUIRED LANDSCAPING IN ACCORDANCE WITH SECTION 16.124 OF THE LANDSCAPE MANUAL IN THE AMOUNT OF \$300 FOR ONE (1) SHADE TREE. FINANCIAL SURETY FOR THE REQUIRED LANDSCAPING MUST BE POSTED AS PART OF THE GRADING OR BUILDING PERMIT.
- THE OWNER, TENANT, AND/OR THEIR AGENTS SHALL BE RESPONSIBLE FOR MAINTENANCE OF THE REQUIRED LANDSCAPING, INCLUDING BOTH PLANT MATERIALS AND BERMS, FENCES AND WALLS. ALL PLANT MATERIALS SHALL BE MAINTAINED IN GOOD GROWING CONDITION, AND WHEN NECESSARY, REPLACED WITH NEW MATERIALS TO ENSURE CONTINUED COMPLIANCE WITH APPLICABLE REGULATIONS. ALL OTHER REQUIRED LANDSCAPING SHALL BE PERMANENTLY MAINTAINED IN GOOD CONDITION AND WHEN NECESSARY, REPAIRED OR REPLACED.
- AT THE TIME OF INSTALLMENT, ALL PLANTINGS HEREWITH LISTED AND APPROVED FOR THIS SITE SHALL BE OF THE PROPER SIZE REQUIREMENTS IN ACCORDANCE WITH THE HOWARD COUNTY LANDSCAPING MANUAL. IN ADDITION, NO SUBSTITUTIONS OR RELOCATION OF REQUIRED PLANTINGS MAY BE MADE WITHOUT PRIOR REVIEW AND APPROVAL FROM THE DEPARTMENT OF PLANNING AND ZONING. ANY DEVIATION FROM THIS APPROVED LANDSCAPE PLAN MAY RESULT IN DENIAL OR DELAY IN THE RELEASE OF LANDSCAPE SURETY UNTIL SUCH TIME AS ALL REQUIRED MATERIALS ARE PLANTED AND/OR REVISIONS ARE MADE TO APPLICABLE PLANS AND CERTIFICATES.

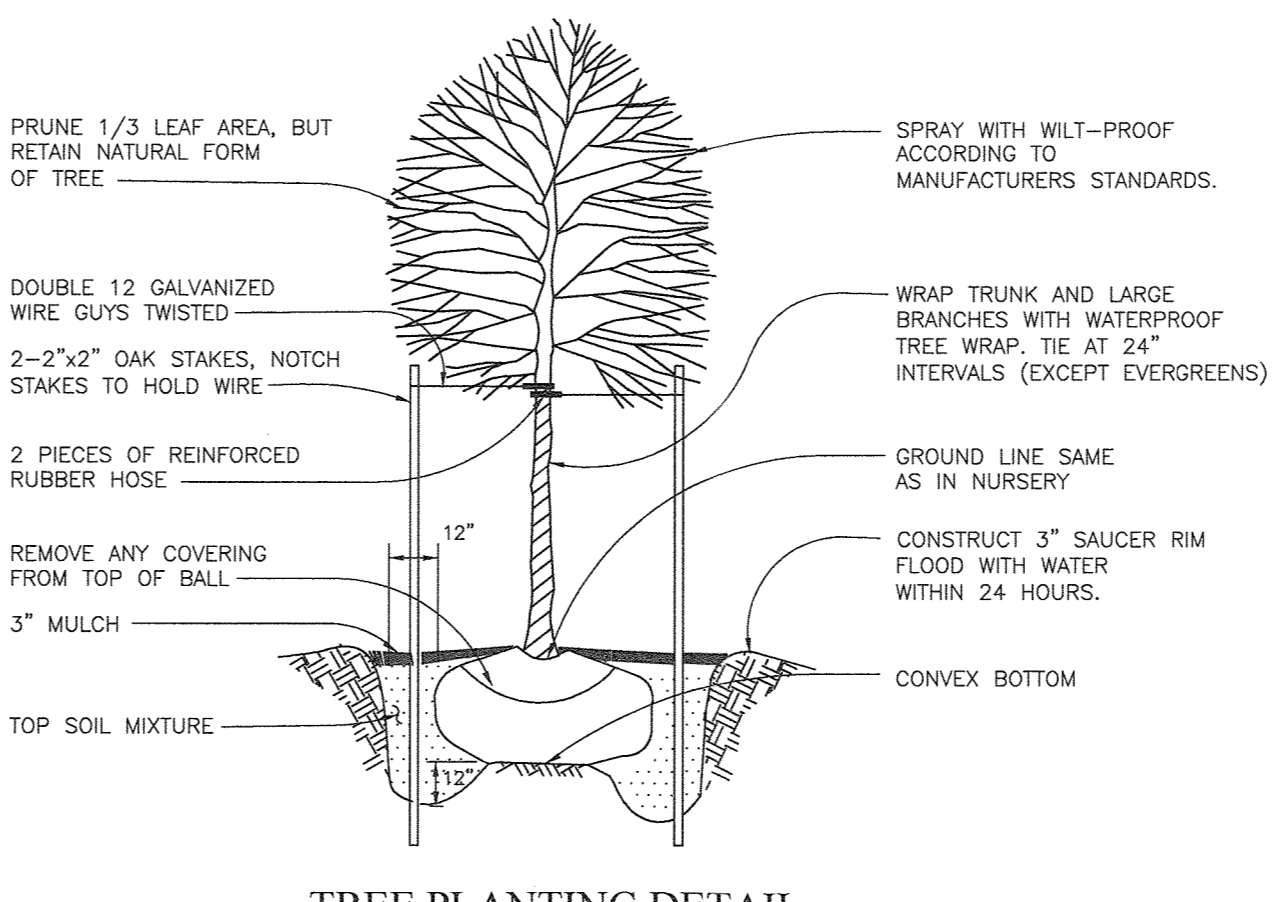

LEGEND

EXISTING SPOT ELEVATION + 348.81
 PROPOSED GRADE SPOT ELEVATION + 50.04

EXISTING STREAM

EXISTING STRUCTURE

NEW CONCRETE

HANDRAIL

EXISTING CONCRETE EDGE

LANDSCAPE PERIMETER

LANDSCAPE CREDIT

EXISTING PAVEMENT TO BE REMOVED

SOILS CLASSIFICATION Ma.D

SOILS DELINEATION

LANDSCAPE TREE

DEVELOPER'S/BUILDER'S CERTIFICATE

I/WE CERTIFY THAT THE LANDSCAPING SHOWN ON THIS PLAN WILL BE DONE ACCORDING TO THE PLAN, SECTION 16.124 OF THE HOWARD COUNTY SUBDIVISION AND LAND DEVELOPMENT REGULATIONS AND LANDSCAPE MANUAL. I/WE FURTHER CERTIFY THAT UPON COMPLETION OF A LETTER OF LANDSCAPE INSTALLATION, ACCOMPANIED BY AN EXECUTED ONE-YEAR GUARANTEE OF PLANT MATERIALS, WILL BE SUBMITTED TO THE DEPARTMENT OF PLANNING AND ZONING.

Stan Mychal 1/3/2020
 DEVELOPER - EMPIRE, LLC DATE

APPROVED: HOWARD COUNTY DEPARTMENT OF PLANNING AND ZONING

Chad Clark 1-3-20
 CHIEF, DEVELOPMENT ENGINEERING DIVISION DATE

David Mann 1/3/20
 CHIEF, DIVISION OF LAND DEVELOPMENT DATE

Jeff Gorn 1-3-20
 DIRECTOR DATE

1 6-3-2020 ADD AIR HANDLER UNITS, CONDENSER UNIT AND WALLS

NO. DATE REVISION

BENCHMARK ENGINEERING, INC.
 8480 BALTIMORE NATIONAL PIKE & SUITE 315 • ELICOTT CITY, MARYLAND 21043
 (P) 410-465-8105 (F) 410-465-8544
 WWW.BEI-CHALLENGEENGINEERING.COM

Professional Certification. I hereby certify that these documents were prepared or approved by me, and that I am a duly licensed professional engineer under the laws of the State of Maryland. License No. 45272, Expiration Date: 06-08-2020.

John M. Cay 12/31/19

OWNER/DEVELOPER: EMPIRE LLC
 C/O PROFESSIONAL ARTS PHARMACY
 2015 LORD BALTIMORE DR
 WOODLAWN, MD 21244
 443-200-1200

HUBBLE / KAISER PARCEL A
 PLAT NUMBER 18699

TAX MAP: 17 GRID: 24 PARCEL: 436
 ZONED: B-2
 3138 ROGERS AVENUE
 ELLICOTT CITY, MD 21043
 ELECTION DISTRICT NO. 2 HOWARD COUNTY, MARYLAND

ALTERNATIVE COMPLIANCE EXHIBIT
 PARKING LOT MANEUVERING ABILITY EXHIBIT, SOILS MAP, LANDSCAPE AND SWM PLAN

DATE: DEC. 31, 2019 BEI PROJECT NO. 2972

DESIGN: JC DRAFT: JC SCALE: 1" = 10' SHEET 3 OF 3