

INDEX

SHEET NO.	DESCRIPTION
1	COVER SHEET
2	ROAD PLAN & PROFILE
3	GRADING & SEDIMENT CONTROL PLAN
4	DRAINAGE AREA MAP
5	STORM DRAIN PROFILES
6	SWM PLAM & DETAILS
7	LANDSCAPE & FOREST CONSERVATION PLAN

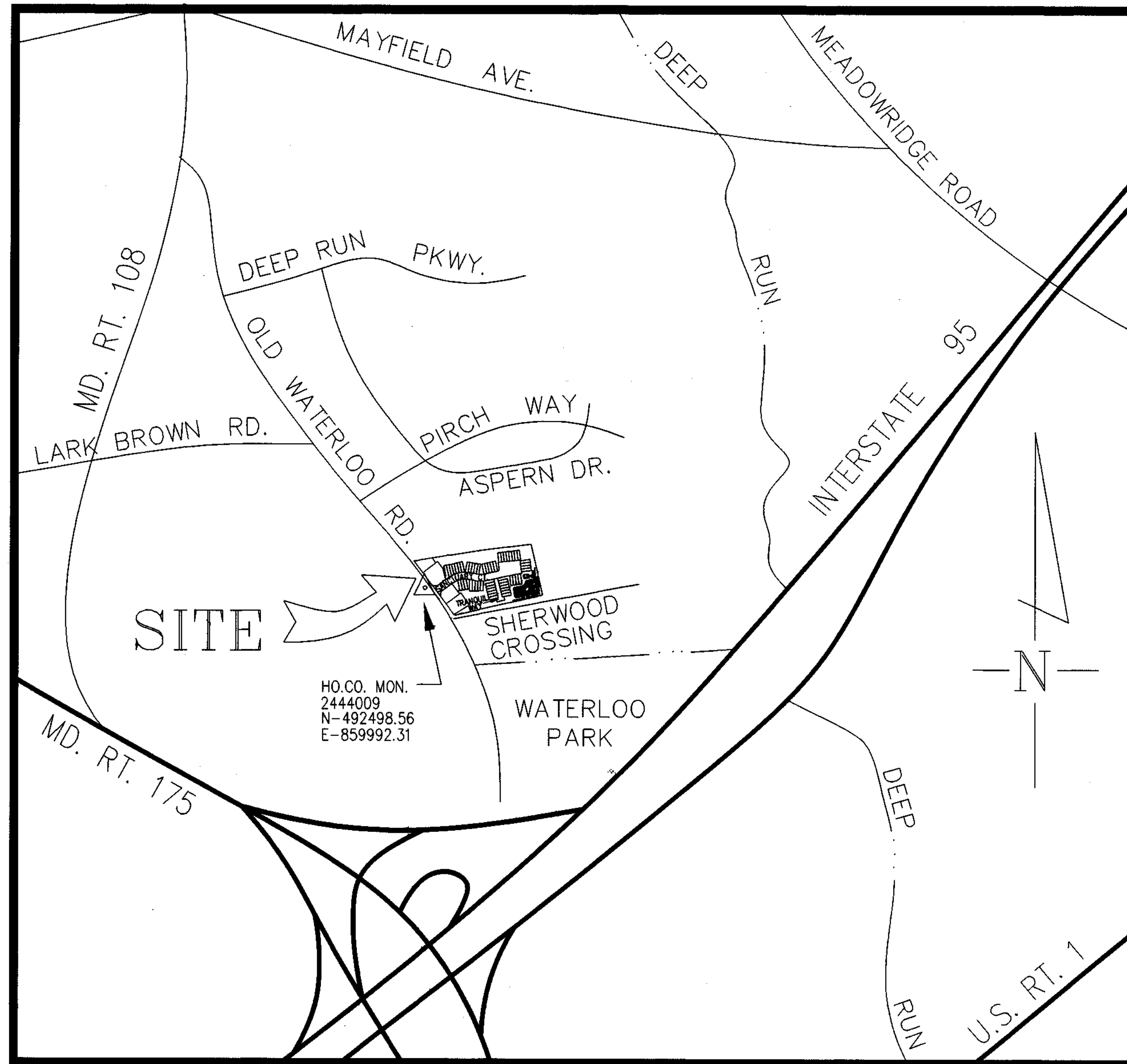

VICINITY MAP
SCALE: 1" = 600'

GENERAL NOTES:

- All work shall be performed in accordance with the Howard County Design Manual, Vol. IV.e. Standard Specifications and Details for Construction.
- Approximate location of existing utilities are shown. The contractor shall take all necessary precautions to protect the existing utilities and maintain uninterrupted service. Any damage incurred due to Contractor's operation shall be repaired immediately at the Contractor's expense.
- The Contractor shall test pit existing utilities at least five (5) days before starting work shown on these drawings.
- Contractor shall notify the following Utilities at least five (5) days before starting work on these drawings:

MISS UTILITY	1-800-257-7777
BELL TELEPHONE SYSTEM	393-3649
LONG DISTANCE CABLE DIVISION	393-3553 or 3553
BALTIMORE GAS & ELECTRIC CO.	539-8000 ext. 691
COLONIAL PIPELINE	795-1390
HOWARD COUNTY BUREAU OF UTILITIES	992-2366
HOWARD COUNTY CONSTRUCTION INSPECTION DIVISION	313-1872
(24 HOURS NOTICE PRIOR TO COMMENCEMENT OF WORK)	
- All inlets shall be constructed in accordance with Howard County Standards.
- All street curb returns shall have a 35' radius unless otherwise noted.
- Storm drain trenches within the road right-of-way shall be backfilled and compacted in accordance with Howard County Design Manual, Vol. IV.e. Standard Specifications and Details for Construction.
- Installation of traffic control devices, marking, and signing shall be in accordance with the most current edition of the MUTCO.
- Pipe shall not be installed by the contractor until the length called for at each station has been approved by the Engineer in the field.
- Designed traffic speed in accordance with the American Association of State Highway Official Standards.
All 50' Right-of-Way = 30 M.P.H.
- All elevations shown are based on U.S.C. and G.S. mean sea level Datum, 1929.
- All fill areas within the roadway and under structures to be compacted to a minimum of 95% compaction, per AASHTO T-180 Method.
- All pipe elevations shown are invert elevation.
- Profile station shall be adjusted as necessary to conform to plan dimensions.
- Subject property zoned RSA-8 PER 10-18-95 Comprehensive Zoning plan.
- Field run topography was prepared by R.C. Kelly & Assoc. Inc. March 1997.
- No pipe shall be laid until lines of excavation have been brought within 6" of finished grade.
- All storm drain pipe bedding shall be as shown in fig. 11.4 Vol. I of Howard County Design Manual unless otherwise noted.
- See Department of Planning and Zoning File No. # S-94-25, P-97-07.
- No wetlands were found on site.
- The Forest Conservation Easement has been established to fulfill the requirements of Section 16.1200 of the Howard County Code Forest Conservation Easement; however, forest management practices as defined in the Deed of Forest Conservation are allowed.

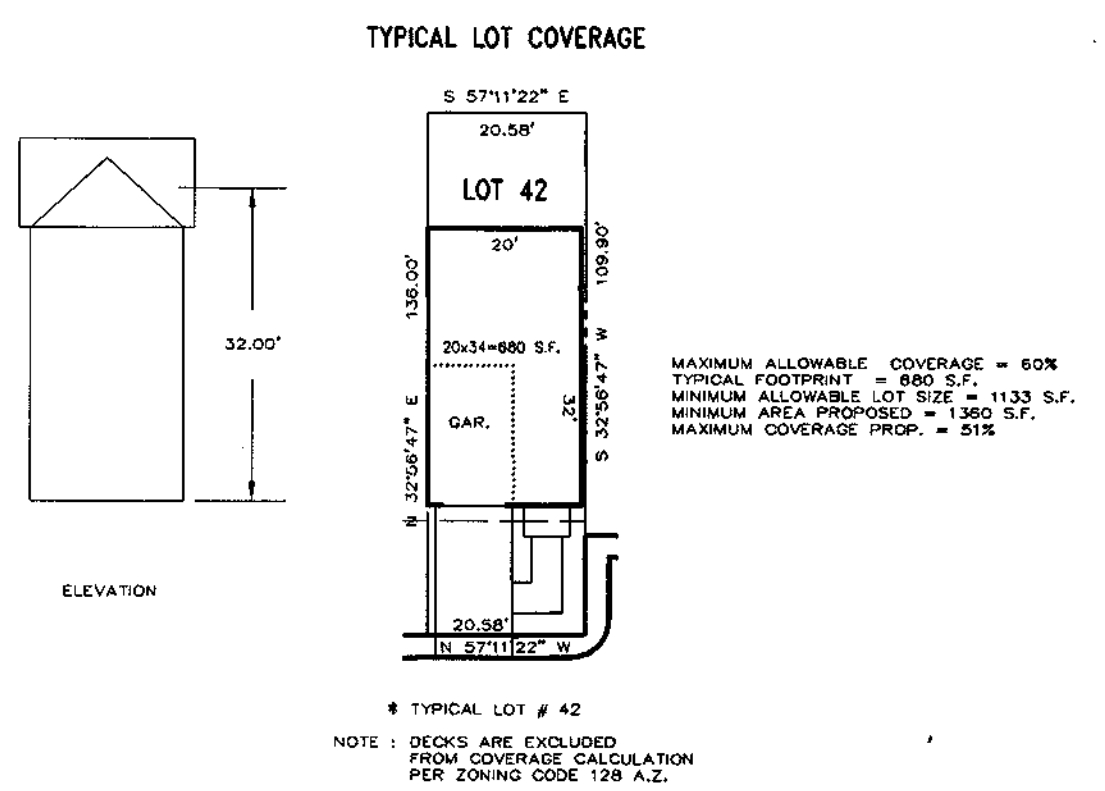

FINAL CONSTRUCTION PLAN

THE SANCTUARY

LOTS 1-61

A SUBDIVISION OF PARCEL 164, 165, 166, 564, 565 AND 566

1st ELECTION DISTRICT TAX MAP 37

HOWARD COUNTY, MARYLAND

NO.	DATE	REVISION
1	7/21/97	APPROVED: HOWARD COUNTY DEPARTMENT OF PLANNING AND ZONING
2	7/21/97	APPROVED: HOWARD COUNTY DEPARTMENT OF PUBLIC WORKS

PREPARED BY:
AMERICAN LAND DEVELOPMENT AND ENGINEERING INC.
CIVIL ENGINEERING CONSULTANTS AND LAND PLANNER
671-A MAIN STREET LAUREL, MD. 20707
BALT. (410) 880-3039
WASH. (301) 953-1221

DES	DRN	CHK	DATE	BY	NO.	REVISION	DATE
D.C.W.	A.V.G.	J.H.E.	6-17-97				

DEVELOPER:
BUNRATTY INVESTMENTS LTD.
P.O. BOX 999
COLUMBIA, MARYLAND 21044

OWNER:
MR. ROBERT O'LEXY
6893 OLD WATERLOO ROAD
BALTIMORE, MARYLAND 20794
MR. GLORIA M. DIETRICH
6719 OLD WATERLOO ROAD
BALTIMORE, MARYLAND 20794

COVER PAGE
600' SCALE MAP NO. 37 BLOCK NO. 21



DEVELOPER'S/BUILDER'S CERTIFICATE
"I/We certify that all development and/or construction will be done according to these plans, and that any responsible involved in the construction project will have a Certificate of attendance at a Department of the Environment Approved Training Program for the Control of Sediment and Erosion before beginning the project. I also authorize periodic on-site inspections by the Howard Soil Conservation District."
James [Signature] 7/23/97
BUILDER/DEVELOPER DATE

ENGINEER'S CERTIFICATE
"I hereby certify that this plan for Soil, Erosion and Sediment control represents a practical and workable plan based on my knowledge of the site conditions. This plan was prepared in accordance with the requirements of the Howard Soil Conservation District."
David W. [Signature] 6/15/97
SIGNATURE OF ENGINEER DATE

THE SANCTUARY
LOTS 1-61
A SUBDIVISION OF PARCEL 164, 165, 166, 564, 565, AND 566
8-94-25, P-97-07
1st ELECTION DISTRICT TAX MAP 37
HOWARD COUNTY, MARYLAND

SCALE AS SHOWN
SHEET 1 OF 7

FILE: C:\DRG\SANCTUARY\Plotted: Thu Jun 19 11:59:37 1997

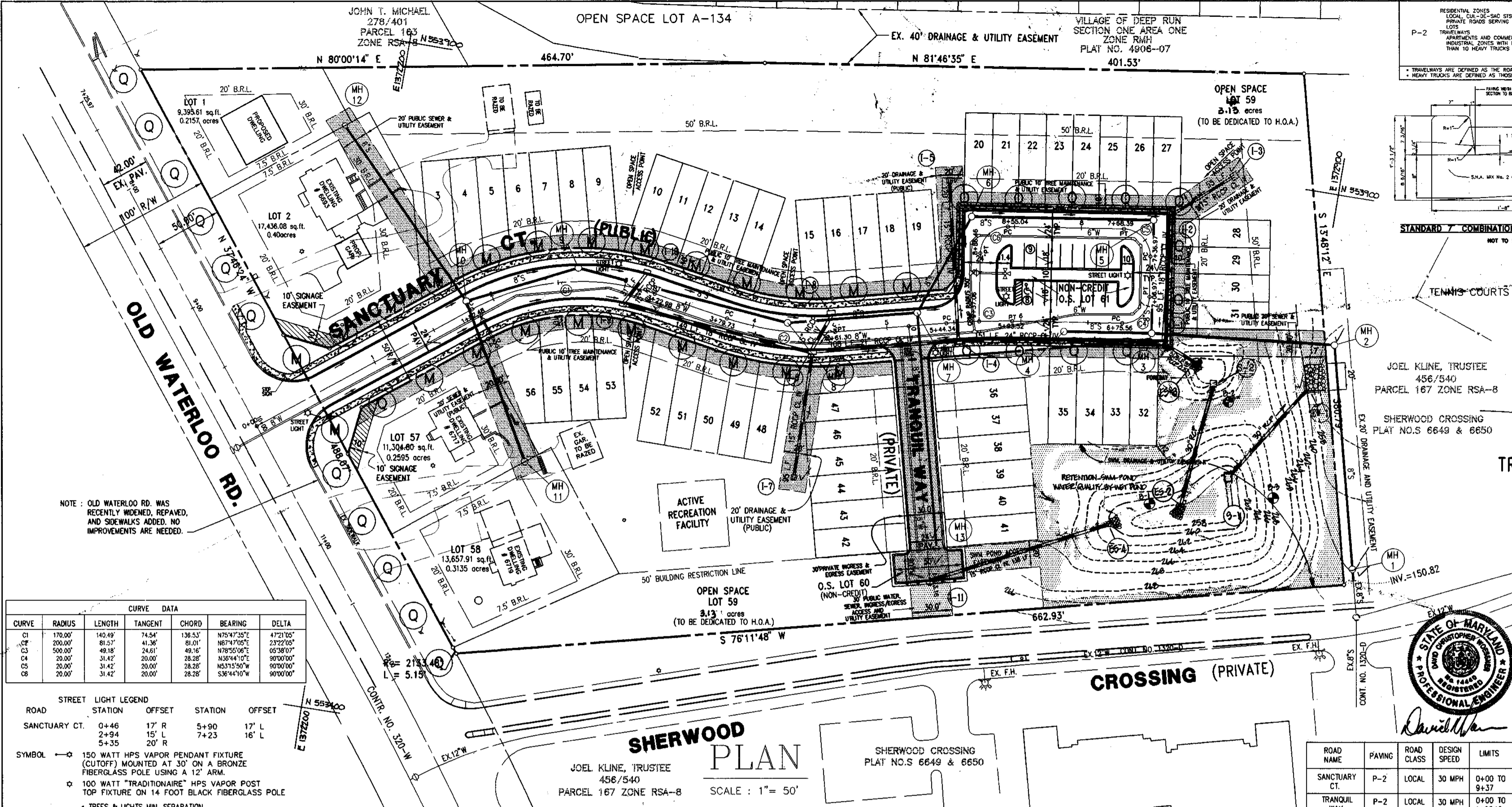

CURVE DATA					
CURVE	RADIUS	LENGTH	TANGENT	CHORD	DELTA
C1	170.00'	142.49'	74.54'	138.53'	178°17'25"
C2	200.00'	81.57'	41.36'	80.01'	187°17'02"
C3	500.00'	49.18'	24.61'	49.16'	178°50'06"
C4	20.00'	31.42'	20.00'	28.28'	102°04'07"
C5	20.00'	31.42'	20.00'	28.28'	102°04'07"
C6	20.00'	31.42'	20.00'	28.28'	102°04'07"

STREET LIGHT LEGEND				
ROAD	STATION	OFFSET	STATION	OFFSET
SANCTUARY CT.	0+46	17' R	5+90	17' L
	2+94	15' L	7+23	16' L
	5+35	20' R		

SYMBOL: 150 WATT HPS VAPOR PENDANT FIXTURE (CUTOFF) MOUNTED AT 30' ON A BRONZE FIBERGLASS POLE USING A 12" ARM.
 100 WATT "TRADITIONARE" HPS VAPOR POST TOP FIXTURE ON 14 FOOT BLACK FIBERGLASS POLE
 * TREES & LIGHTS MIN. SEPARATION

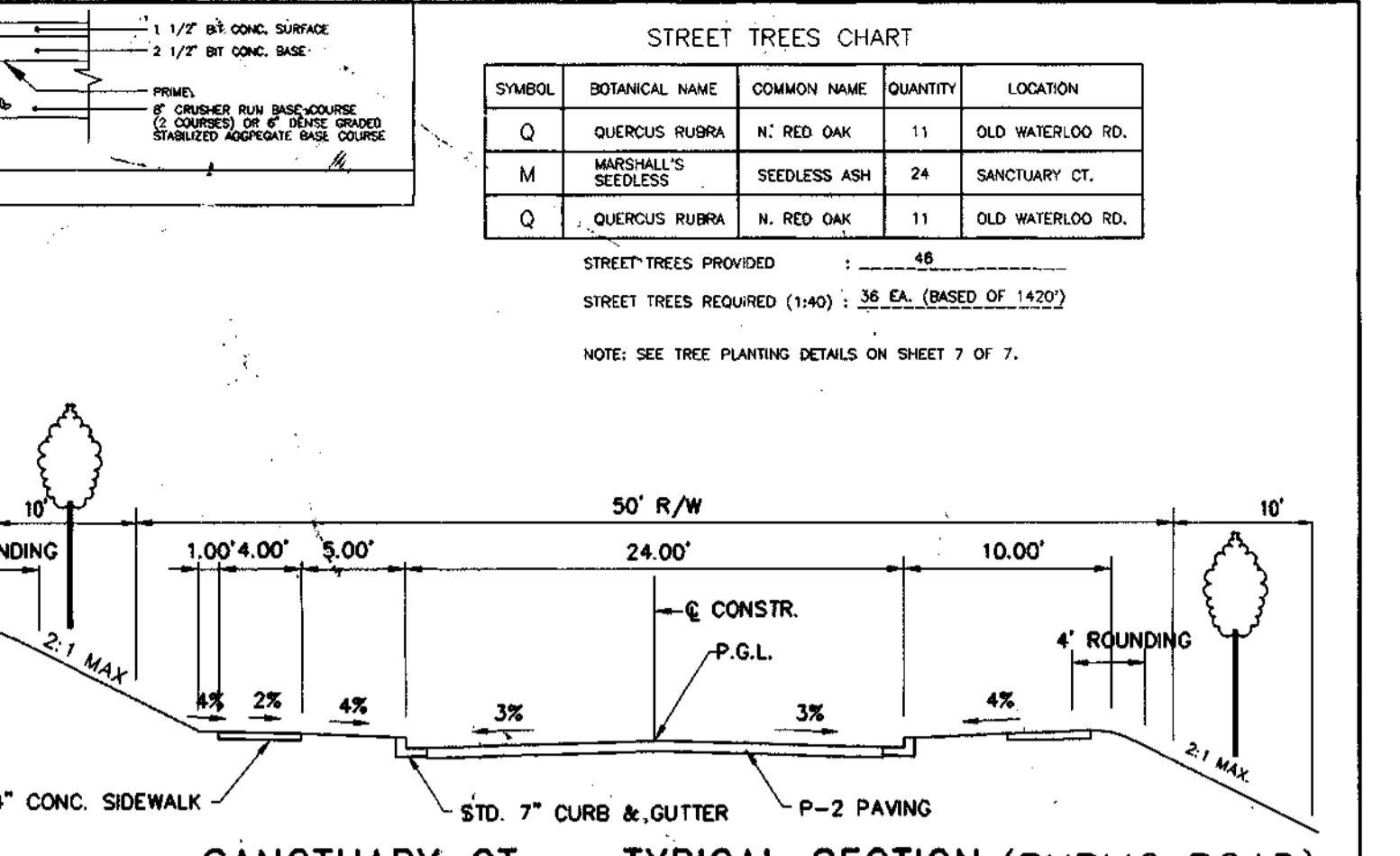
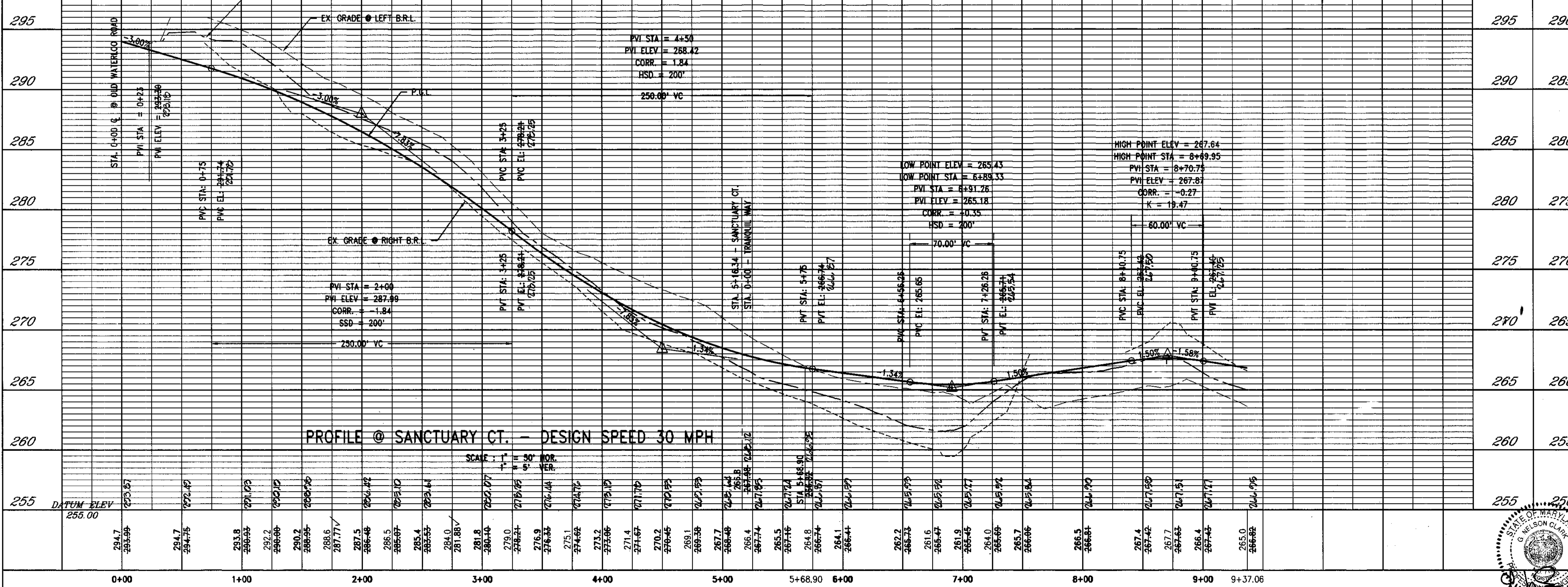

STREET TREES CHART			
SYMBOL	BOTANICAL NAME	COMMON NAME	QUANTITY
Q	QUERCUS RUBRA	N. RED OAK	11
M	MARSHALLS SEEDLESS	SEEDLESS ASH	24
Q	QUERCUS RUBRA	N. RED OAK	11

SANCTUARY CT. - TYPICAL SECTION (PUBLIC ROAD)	
NO.	REVISION
1	12-16-99 REVISED PER AS-BUILT CONDITIONS
2	10-9-97 SANCTUARY CT. - (PUBLIC)

THE SANCTUARY	
PROJECT NAME	LOTS 1-61
P-97-07	A SUBDIVISION OF PARCELS 164,165,166,564,565 & 566
S-94-25	FIRST ELECTION DISTRICT TAX MAP #37
	HOWARD COUNTY, MARYLAND

ENGINEER'S CERTIFICATE
 I certify that this plan for pond construction, erosion and sediment control represents a practical and workable plan based on my knowledge of the site conditions. This plan was prepared in accordance with the requirements of the Howard Soil Conservation District. I have notified the developer that he/she must engage a registered professional engineer to supervise pond construction and provide the Howard Soil Conservation District with an "as-built" plan of the pond within 30 days of completion.
 Signature: David W. Kline
 Date: 6/15/97

DEVELOPER'S/BUILDER'S CERTIFICATE
 I/we certify that all development and/or construction will be done according to these plans, and that any responsible involved in the construction project will have a Certificate of attendance of a Department of the Environment Approved Training Program for the Control of Sediment and Erosion before beginning the project. I shall engage a registered professional engineer to supervise pond construction and provide the Howard Soil Conservation District with an "as-built" plan of the pond within 30 days of completion. I also authorize periodic on-site inspections by the Howard Soil Conservation District.
 Signature: David W. Kline
 Date: 7/3/97

ROAD NAME	PAVING	ROAD CLASS	DESIGN SPEED	LIMITS
SANCTUARY CT.	P-2	LOCAL	30 MPH	0+00 TO 9+37
TRANQUIL WAY	P-2	LOCAL	30 MPH	0+00 TO 1+31.16

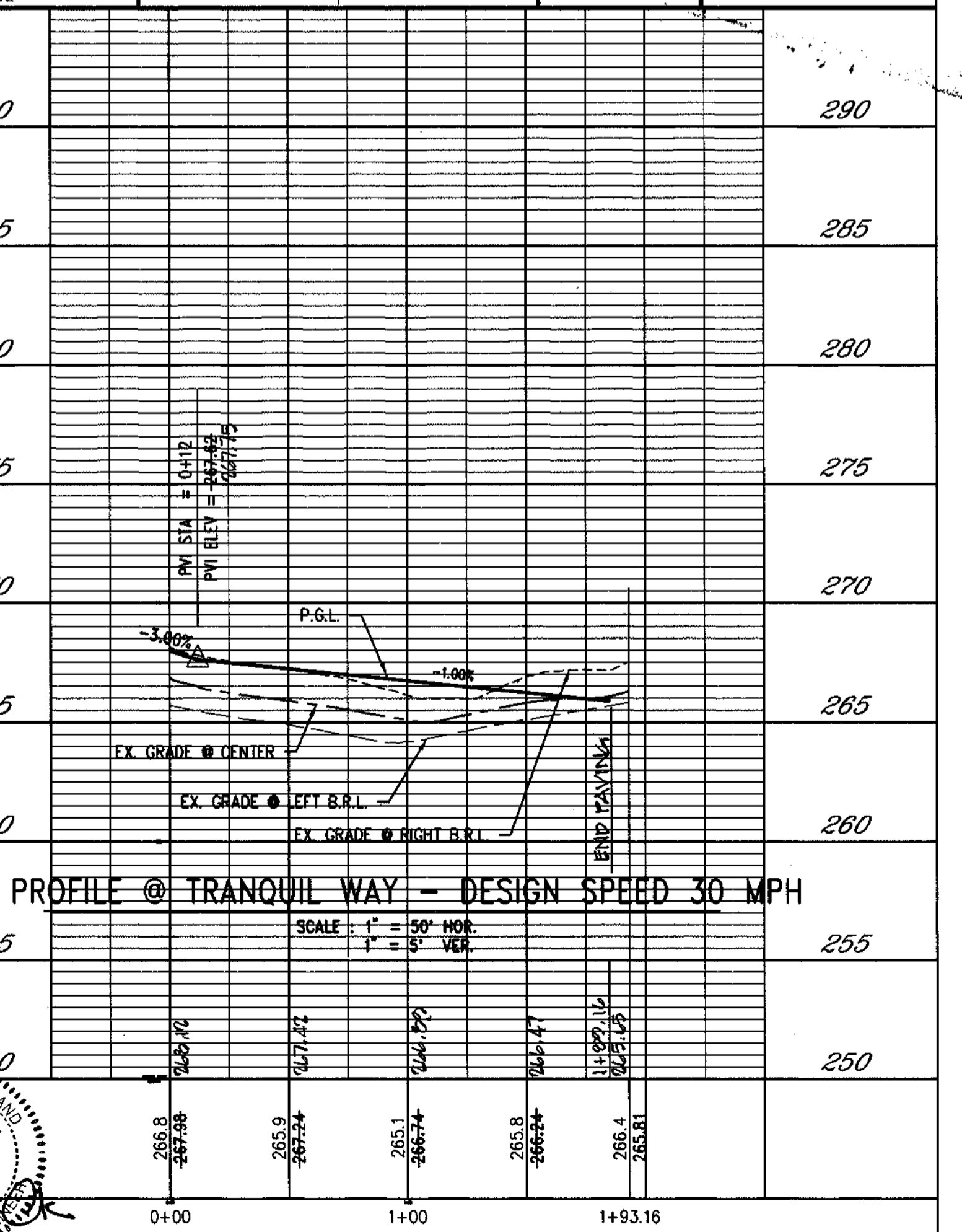
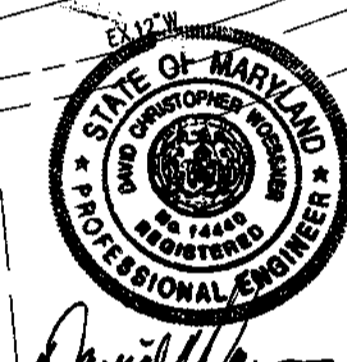

PROFILE @ TRANQUIL WAY - DESIGN SPEED 30 MPH	
DES.	D.C.W.
JOB	
DRW.	AVG
PROJ.	SANCRD.DWG
CHK.	D.C.W.
DATE	6-18-97
SCALE	1" = 50'
SHEET	2 OF 7

12.14
 File: C:\DWS\GMS\AS-BUILT.Plotfile: Thu Jun 19 12:23:28 1997

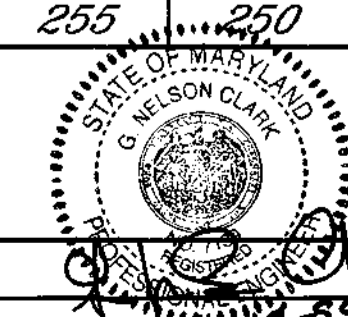

AS-BUILT 12-16-99 F-97-160

STANDARD SEDIMENT CONTROL NOTES:

- A minimum of 48 hours notice shall be given to the Howard County Dept. of Planning and Zoning prior to the start of any construction.
- All existing and structural provisions are to be installed according to the specifications of the State of Maryland, Department of Transportation, Standard Specifications for Road and Bridge Construction, 1988 Edition, and the specifications of the Howard County Department of Planning and Zoning, Standard Specifications for Road and Bridge Construction, 1988 Edition.
- Following initial soil disturbance or construction, permanent or temporary sedimentation control shall be installed within 48 hours of the start of construction. Sedimentation control shall be installed in accordance with the specifications of the Howard County Department of Planning and Zoning, Standard Specifications for Road and Bridge Construction, 1988 Edition.
- Any sediment control structure must be placed and working prior to the start of any construction. Sedimentation control shall be installed in accordance with the specifications of the Howard County Department of Planning and Zoning, Standard Specifications for Road and Bridge Construction, 1988 Edition.
- All disturbed areas must be stabilized within the time period specified above in accordance with the 1983 Revised Standards and Specifications for Road and Bridge Construction, Department of Transportation, Standard Specifications for Road and Bridge Construction, 1988 Edition.
- Any sediment control structure must be placed and working prior to the start of any construction. Sedimentation control shall be installed in accordance with the specifications of the Howard County Department of Planning and Zoning, Standard Specifications for Road and Bridge Construction, 1988 Edition.
- Any sediment control structure must be placed and working prior to the start of any construction. Sedimentation control shall be installed in accordance with the specifications of the Howard County Department of Planning and Zoning, Standard Specifications for Road and Bridge Construction, 1988 Edition.
- Any sediment control structure must be placed and working prior to the start of any construction. Sedimentation control shall be installed in accordance with the specifications of the Howard County Department of Planning and Zoning, Standard Specifications for Road and Bridge Construction, 1988 Edition.
- Any sediment control structure must be placed and working prior to the start of any construction. Sedimentation control shall be installed in accordance with the specifications of the Howard County Department of Planning and Zoning, Standard Specifications for Road and Bridge Construction, 1988 Edition.
- Any sediment control structure must be placed and working prior to the start of any construction. Sedimentation control shall be installed in accordance with the specifications of the Howard County Department of Planning and Zoning, Standard Specifications for Road and Bridge Construction, 1988 Edition.

PERMANENT SEDIMENT NOTES:

Apply to ponds of 1000 sq. ft. or more. Ponds shall be constructed in accordance with the specifications of the Howard County Department of Planning and Zoning, Standard Specifications for Road and Bridge Construction, 1988 Edition.

TEMPORARY SEDIMENT NOTES:

Apply to ponds of 1000 sq. ft. or more. Ponds shall be constructed in accordance with the specifications of the Howard County Department of Planning and Zoning, Standard Specifications for Road and Bridge Construction, 1988 Edition.

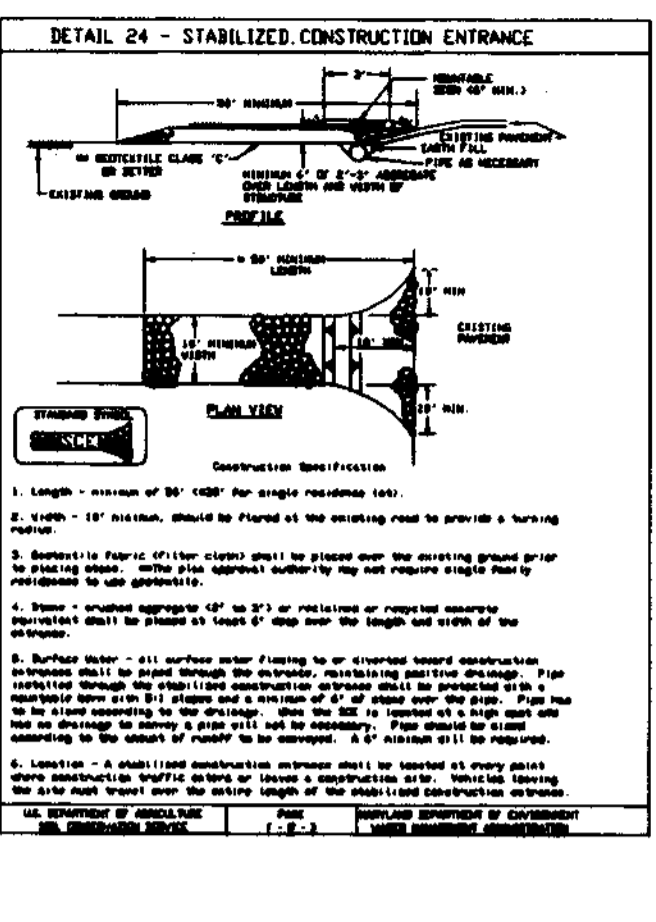
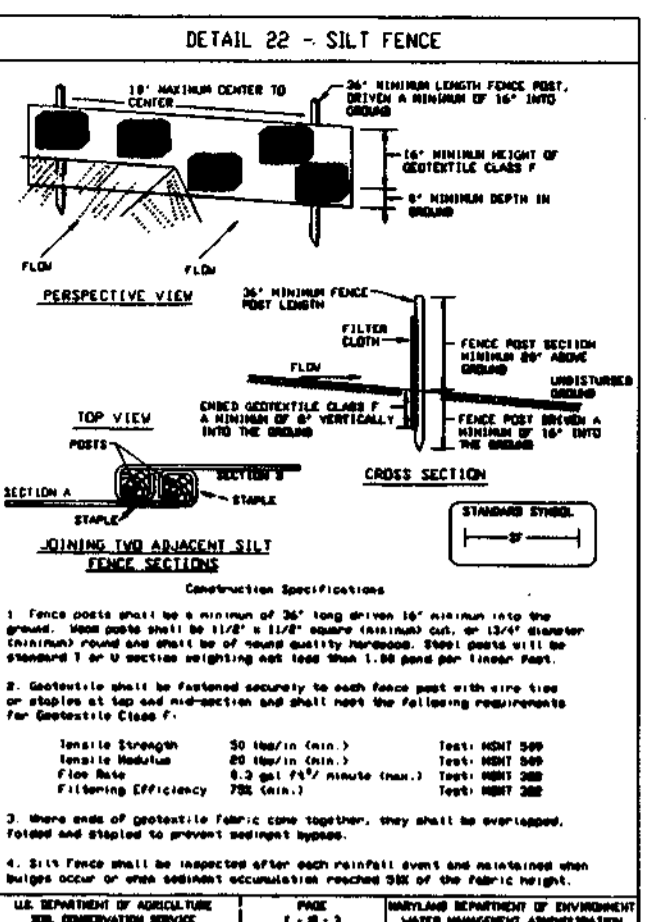

- SEQUENCE OF CONSTRUCTION**
- OBTAIN A GRADING PERMIT - 3 DAYS
 - INSTALL STABILIZED CONSTRUCTION ENTRANCE - 1 DAY
 - CLEAR AND GRUB AREAS FOR INSTALLING SILT FENCE AND PERIMETER DIKES - 4 DAYS
 - INSTALL SILT FENCE AND PERIMETER DIKES - 1 1/2 WEEKS
 - CONSTRUCT STORMWATER MANAGEMENT AS SEDIMENT BASIN #1 - 2 1/2 WEEKS
 - ROUGH GRADE SITE - 2 WEEKS
 - CONSTRUCT ROADS SANITARY CT & TRANQUIL WAY SURFACE - 6 WEEKS
 - CONSTRUCT STORM DRAIN AND OTHER UTILITIES AND INSTALL INLET PROTECTIONS - 4 1/2 WEEKS
 - REMOVE STABILIZED CONSTRUCTION ENTRANCE AND CONSTRUCT BASE COURSE FOR ROADS SANITARY CT AND TRANQUIL WAY - 1 WEEK
 - INSTALL AND SEED & MULCH ALL AREAS DISTURBED - 1 WEEKS
 - UPON APPROVAL OF THE SEDIMENT CONTROL INSPECTOR, REMOVE ALL SEDIMENT CONTROL DEVICES - 1 WEEKS
 - CONVERT SEDIMENT BASIN #1 TO STORMWATER MANAGEMENT THEN ALL DISTURBED AREAS ARE STABILIZED, SEED AND MULCHED - 1 WEEKS
 - APPROPRIATION TO BE PERFORMED AFTER TRAVELWAY CONSTRUCTION.

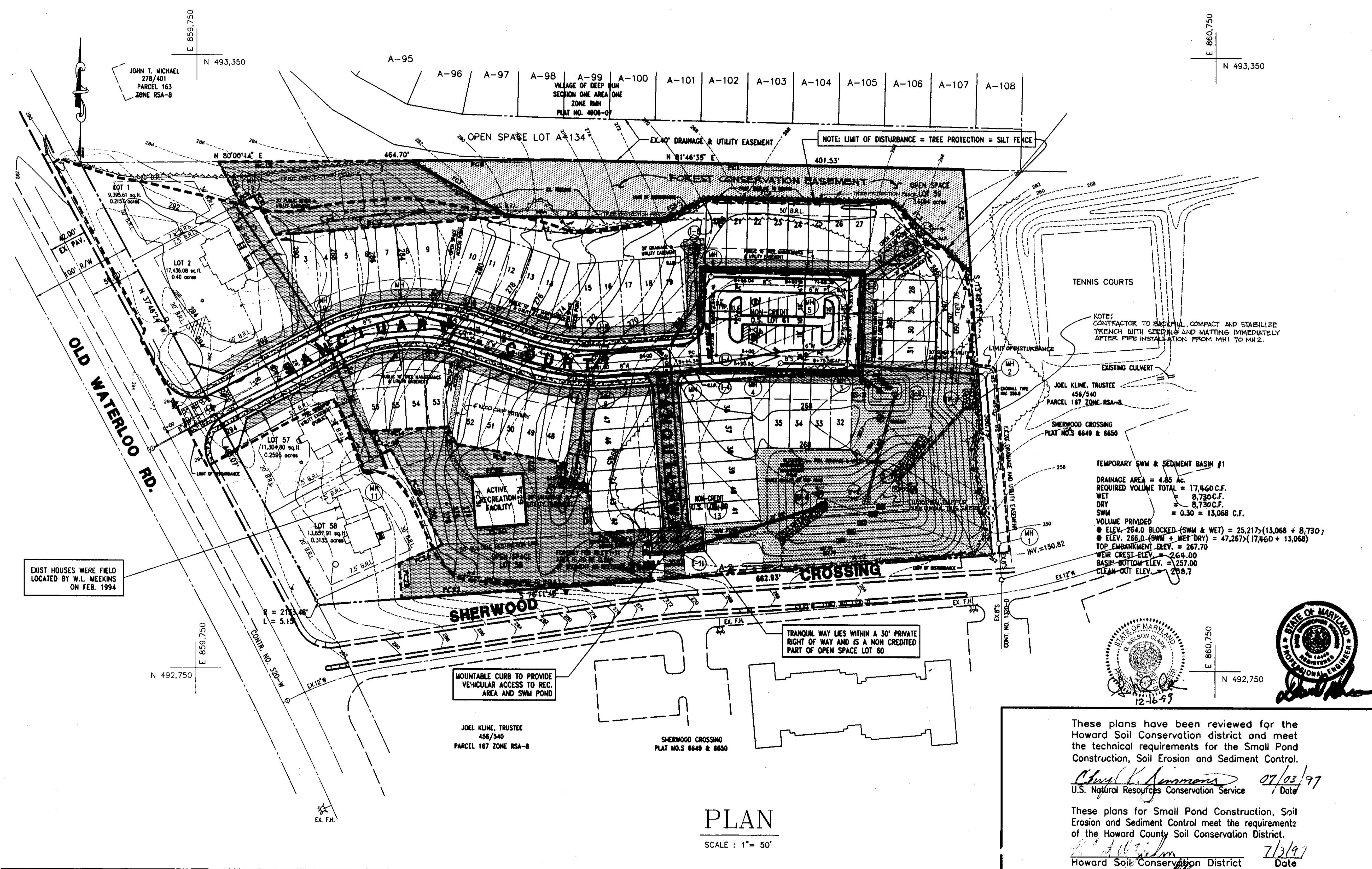
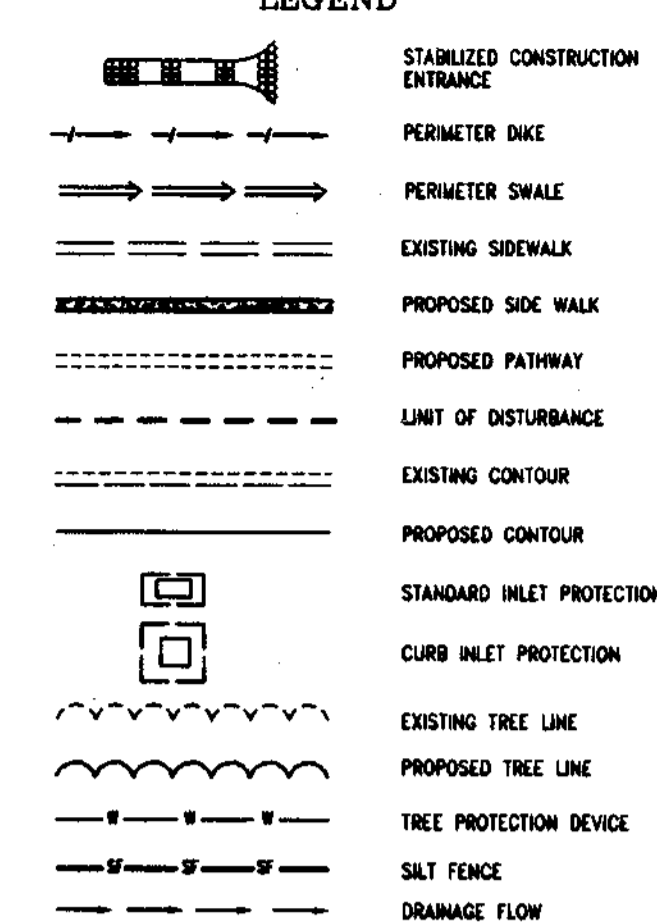

DEVELOPER'S/BUILDER'S CERTIFICATE

"I/We certify that all development and/or construction will be done according to these plans, and that any responsible involved in the construction project will have a Certificate of attendance at a Department of the Environment Approved Training Program for the Control of Sediment and Erosion before beginning the project. I shall engage a registered professional engineer to supervise pond construction and provide the Howard Soil Conservation District with an "as-built" plan of the pond within 30 days of completion. I also authorize periodic on-site inspections by the Howard Soil Conservation District."

[Signature]
BUILDER/DEVELOPER

DATE

ENGINEER'S CERTIFICATE

"I certify that this plan for pond construction, erosion and sediment control represents a practical and workable plan based on my knowledge of the site conditions. This plan was prepared in accordance with the requirements of the Howard Soil Conservation District. I have notified the developer that he/she must engage a registered professional engineer to supervise pond construction and provide the Howard Soil Conservation District with an "as-built" plan of the pond within 30 days of completion."

[Signature]
SIGNATURE OF ENGINEER

DATE

NO.	DATE	REVISION
		APPROVED: HOWARD COUNTY DEPARTMENT OF PLANNING AND ZONING
		<i>[Signature]</i> CHIEF, DIVISION OF LAND DEVELOPMENT 7/31/97 DATE
		<i>[Signature]</i> CHIEF, DEVELOPMENT ENGINEERING DIVISION 7/17/97 DATE
		APPROVED: HOWARD COUNTY DEPARTMENT OF PUBLIC WORKS
		<i>[Signature]</i> CHIEF, BUREAU OF HIGHWAYS 7-11-97 DATE

PROJECT NAME		THE SANCTUARY	
P-97-07		A SUBDIVISION OF PARCELS 184,165,166,564,565 & 566	
S-94-25		FIRST ELECTION DISTRICT TAX MAP #37	
		HOWARD COUNTY, MARYLAND.	
TITLE	DEVELOPER:	BUNRATTY INVESTMENTS LTD. P.O. BOX 999 COLUMBIA, MARYLAND 21044	
GRADING, SEDIMENT AND EROSION CONTROL PLAN	OWNER:	MR. ROBERT O'LEXY 6693 OLD WATERLOO ROAD BALTIMORE, MARYLAND 20794	
PREPARED BY:	OWNER:	BUNRATTY INVESTMENTS LTD. P.O. BOX 999 COLUMBIA, MARYLAND 21044	
AMERICAN LAND DEVELOPMENT AND ENGINEERING INC. 871-A MAIN STREET LAUREL, MARYLAND 20707 WASH. (301) 963-1821 BALT. (301) 880-3039	OWNER:	MR. GLORIA M. DIETRICH 6719 OLD WATERLOO ROAD BALTIMORE, MARYLAND 20794	
DES.: D.C.W.	JOB:	SCALE:	SHEET 3 OF 7
DRW.: AVG	PROJ.: SANC2SCP.DWG	DATE: 6-19-97	1" = 50'
CHK.: D.C.W.	DATE:		

These plans have been reviewed for the Howard Soil Conservation district and meet the technical requirements for the Small Pond Construction, Soil Erosion and Sediment Control.

[Signature] 07/03/97
U.S. Natural Resources Conservation Service

These plans for Small Pond Construction, Soil Erosion and Sediment Control meet the requirements of the Howard County Soil Conservation District.

[Signature] 7/3/97
Howard Soil Conservation District

PLAN
SCALE: 1" = 50'

File: C:\MG\SAC\SAC2\SAC2DAM Plotted: Thu Jun 19 10:31:52 1997

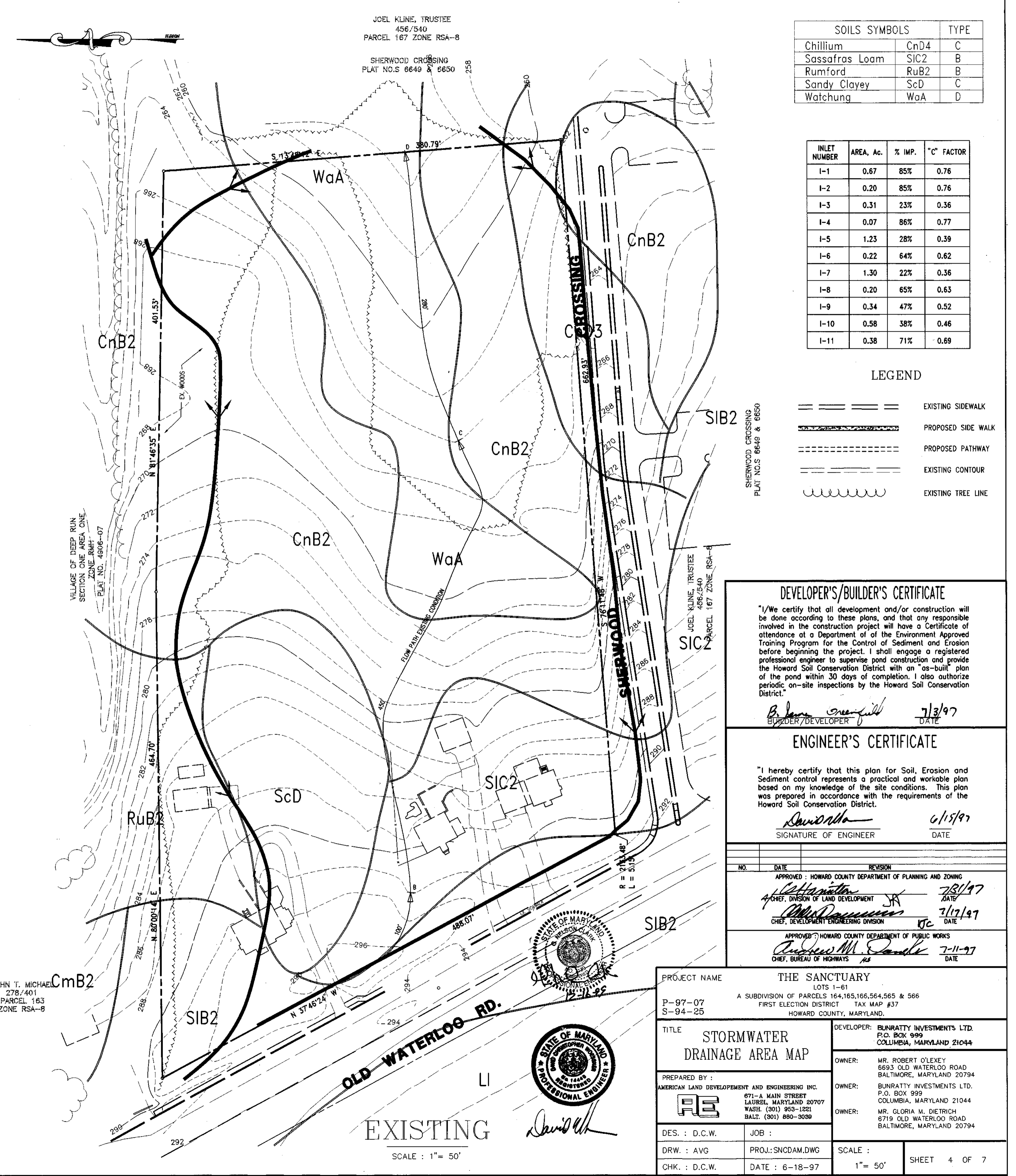
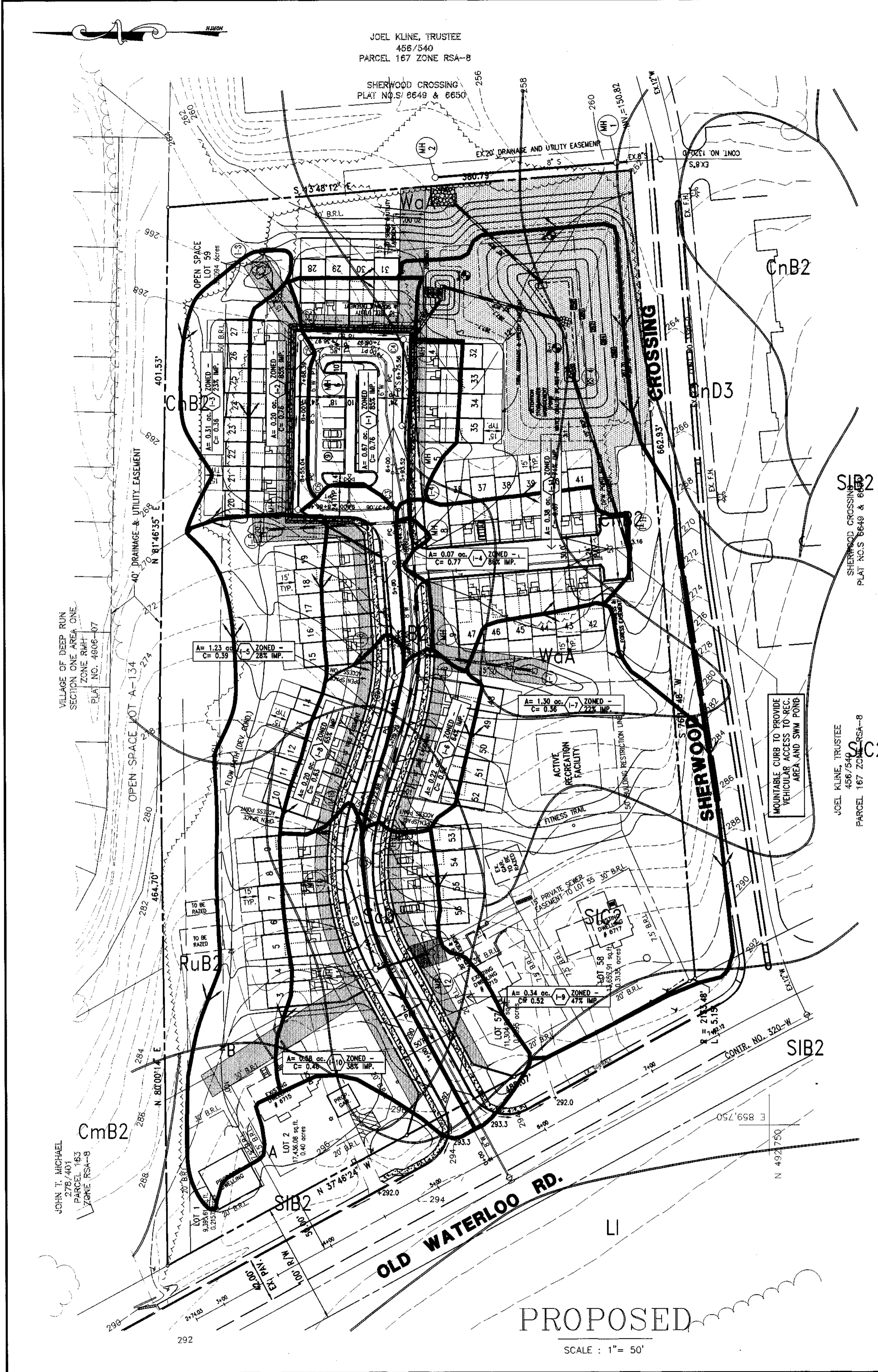

SOILS SYMBOLS		TYPE
Chillium	CnD4	C
Sassafras Loam	SIC2	B
Rumford	RuB2	B
Sandy Clayey	ScD	C
Watchung	WaA	D

INLET NUMBER	AREA, Ac.	% IMP.	"C" FACTOR
I-1	0.67	85%	0.76
I-2	0.20	85%	0.76
I-3	0.31	23%	0.36
I-4	0.07	86%	0.77
I-5	1.23	28%	0.39
I-6	0.22	64%	0.62
I-7	1.30	22%	0.36
I-8	0.20	65%	0.63
I-9	0.34	47%	0.52
I-10	0.58	38%	0.46
I-11	0.58	71%	0.69

LEGEND

- ==== EXISTING SIDEWALK
- PROPOSED SIDE WALK
- PROPOSED PATHWAY
- EXISTING CONTOUR
- ~~~~~ EXISTING TREE LINE

DEVELOPER'S/BUILDER'S CERTIFICATE
 "I/We certify that all development and/or construction will be done according to these plans, and that any responsible involved in the construction project will have a Certificate of Attendants of a Department of the Environment Approved Training Program for the Control of Sediment and Erosion before beginning the project. I shall engage a registered professional engineer to supervise pond construction and provide the Howard Soil Conservation District with an "as-built" plan of the pond within 30 days of completion. I also authorize periodic on-site inspections by the Howard Soil Conservation District."
B. Greenfield 7/3/97
 DEVELOPER/DATE

ENGINEER'S CERTIFICATE
 "I hereby certify that this plan for Soil, Erosion and Sediment control represents a practical and workable plan based on my knowledge of the site conditions. This plan was prepared in accordance with the requirements of the Howard Soil Conservation District."
David M. Danahy 6/15/97
 SIGNATURE OF ENGINEER DATE

APPROVED: HOWARD COUNTY DEPARTMENT OF PLANNING AND ZONING
John T. Michael 7/8/97
 CHIEF, DIVISION OF LAND DEVELOPMENT DATE
David M. Danahy 7/17/97
 CHIEF, DEVELOPMENT ENGINEERING DIVISION DATE
 APPROVED: HOWARD COUNTY DEPARTMENT OF PUBLIC WORKS
Andrew M. Danahy 7-11-97
 CHIEF, BUREAU OF HIGHWAYS DATE

PROJECT NAME THE SANCTUARY LOTS 1-61	
P-97-07 A SUBDIVISION OF PARCELS 164,165,166,564,565 & 566 S-94-25 FIRST ELECTION DISTRICT TAX MAP #37 HOWARD COUNTY, MARYLAND.	
TITLE STORMWATER DRAINAGE AREA MAP	DEVELOPER: BUNRATTY INVESTMENTS LTD. P.O. BOX 999 COLUMBIA, MARYLAND 21044
PREPARED BY: AE AMERICAN LAND DEVELOPMENT AND ENGINEERING INC. 671-A MAIN STREET LAUREL, MARYLAND 20707 WASH. (301) 953-1221 BALT. (301) 880-3098	OWNER: MR. ROBERT O'LEXY 6893 OLD WATERLOO ROAD BALTIMORE, MARYLAND 20794 OWNER: BUNRATTY INVESTMENTS LTD. P.O. BOX 999 COLUMBIA, MARYLAND 21044 OWNER: MR. GLORIA M. DIETRICH 6719 OLD WATERLOO ROAD BALTIMORE, MARYLAND 20794
DES.: D.C.W.	JOB:
DRW.: AVG	PROJ.: SNCDAM.DWG
CHK.: D.C.W.	DATE: 6-18-97
SCALE: 1" = 50'	
SHEET 4 OF 7	

AS-BUILT 12-16-99 F-97-160

POND CONSTRUCTION SPECIFICATIONS

These specifications are appropriate to all ponds within the scope of the Standard for practice MD-378. All references to ASTM and AASHTO specifications apply to most recent version.

SITE PREPARATION :

Areas designated for borrow areas, embankment, and structural works shall be cleared, grubbed and stripped of topsoil. All trees, vegetation, roots and other objectionable material shall be removed. Channel banks and sharp breaks shall be sloped to no steeper than 1:1. Areas to be covered by the reservoir will be cleared of all trees, brush, logs, fences, rubbish and other objectionable materials unless otherwise designated on the plans. Trees, brush, and stumps shall be cut approximately level with the ground surface. For dry storm-water management ponds, a minimum of a 50 foot radius around the inlet structure shall be cleared.

All cleared and grubbed material shall be disposed of outside the limits of the dam and reservoir as directed by the owner or his authorized representative. When specified, a sufficient quality of top soil will be stockpiled in a suitable location for use on the embankment and other designated areas.

Due to poor tractability of soils on the pond site. When saturated excavation shall be done by backhoe or grader. Additionally, when groundwater is encountered during excavation, construction dewatering shall be implemented to facilitate excavation. Soils encountered in Test P.I. B-3 shall not be used for cut-off construction due to high moisture content and low unit weight.

EARTH FILL :

Material :
The fill material shall be taken from approved designated borrow area or areas. It shall be free of roots, stumps, wood, rubbish, stones greater than 6", frozen or other objectionable materials. Fill material for the center of the embankment and cut off trench shall conform to Unified Soil Classification GC, SC, OH, or CL. Consideration may be given to the use of the other materials in the embankment if design and construction are supervised by a geotechnical engineer.

Placement :
Substantial effort shall be made to reduce soil moisture prior to placement and compaction. Consideration shall be given to lime treatment of soils to facilitate placement and compaction. Fills for cut-off trench and embankment construction shall be constructed in 8-inch loose lifts and compacted to with 95% of the dry density in accordance with the Standard Proctor, ASTM D-998 and monitored with in-place density testing performed by a qualified engineering technician under the direction of the P.E.

Area on which fill is to be placed shall be sacrificed prior to placement of the fill. Fill materials shall be placed in 8-inch maximum thickness (before compaction) layers which are to be continuous over the entire length of the fill. The most permeable material below material shall be placed in the downstream portions of the embankment. The principal spillway must be installed concurrently with placement and not excavated into the embankment.

Compaction :
The movement of the hauling and spreading equipment over the fill shall be controlled so that the entire surface of each lift shall be traversed by not less than one third track of the equipment or compaction shall be achieved by a minimum of four complete passes of a sheepsfoot, rubber tired or vibratory roller. Fill material shall contain sufficient moisture such that the required degree of compaction can be obtained with the equipment used. The fill material shall contain sufficient moisture so that if formed into a ball it will not crumble yet not be so wet that water can be squeezed out.

Where a minimum required density is specified, it shall not be less than 95% of maximum dry density with a moisture content within 2% of the optimum. Each layer of fill shall be compacted as necessary to obtain that density, and it is to be certified by the Engineer at the time of construction. All compaction is to be determined by AASHTO Method T-99.

Cut-off Trench

Where specified, a cut-off trench shall be excavated along or parallel to the centerline of the embankment as shown on the plans. The bottom width of the trench shall be governed by the equipment used for excavation. With the minimum width being four feet. The depth shall be at least four feet below existing grade or as shown on the plans. The side slopes of the trench shall be 1 to 1 or flatter. The backfill shall be compacted with construction equipment rollers or hand tampers to assure maximum density and a minimum permeability.

STRUCTURE BACKFILL

Backfill adjacent to pipes or structures shall be of the type and quality conforming to the specifications for the adjoining fill material. The fill shall be placed in horizontal layers not to exceed four inches in thickness and compacted by hand tampers or other manually directed compaction equipment. The material needs to fill completely all spaces under and adjacent to the pipe. At no time during the backfilling operation shall driven equipment be allowed to operate closer than four feet, measured horizontally, to any part of a structure. The backfilling operation shall be driven over any part of a concrete structure or pipe, unless there is a compacted fill of 24" or greater over the structure or pipe.

PIPE CONDUITS

All pipe shall be circular in cross section.

Corrugated Metal Pipe - All of the following criteria shall apply on corrugated metal pipe.

Corrugated metal pipe (steel pipe) - This pipe and its appurtenances shall be galvanized and fully bituminous coated and shall conform to the requirements of AASHTO Specification M-190 type A with water tight coupling bands. Any bituminous coating damaged or otherwise removed shall be placed with cold applied bituminous coating compound. Steel pipes with polymeric coatings shall have a minimum coating thickness of .01 inch (10 mil) on both sides of the pipe. The following coatings or an approved equal may be used: Nexon, Plast-i-Cote, Blac-Klad, and Beth-Cu-Loy. Coated corrugated steel pipe shall meet the requirements of AASHTO M-245 and M-246.

Materials - (Aluminum Coated Steel Pipe) - This pipe and its appurtenances shall conform to the requirements of AASHTO Specification M-274 with watertight coupling bands or flanges. Any aluminum coating damaged or otherwise removed shall be replaced with cold applied bituminous coating compound.

Materials - (Aluminum Pipe) - This pipe and its appurtenances shall conform to the requirements of AASHTO Specification M-196 or M-211 with watertight coupling bands or flanges. Aluminum surfaces that are to be in contact with concrete shall be painted with one coat of zinc chromate primer. Hot dip galvanized soils may be used for connections. The pH of the surrounding soils shall be between 4 and 9.

Coupling band, anti-seep collars, and sections etc., must be composed of the same material as the pipe. Metals must be insulated from dissimilar materials with use of rubber or plastic insulating materials at least 24 mils in thickness.

Connections - All connections with pipes must be completely watertight. The drain pipe or barrel connection to the riser shall be welded all around when the pipe and riser are metal. Anti-seep collars shall be connected to the pipe in such manner as to be completely watertight. Dimple bands are not considered to be watertight.

All connection shall use a rubber or neoprene gasket when joining pipe sections. The end of each pipe shall be re-rolled on adequate number of corrugations to accommodate the gasket width. The following type connection are acceptable for pipe less than 24" in diameter; flanges on both ends of the pipe, a 12" wide standard lap type band with 12" wide by 3/8" thick closed cell circular neoprene gasket, and a 12" wide huffer

type band with o-ring gaskets having a minimum diameter of 1/2" greater than the corrugated depth. Pipes 24" in diameter and larger shall be connected by a 24" long annular corrugated bands using rods and lugs. A 12" wide by 3/8" thick closed cell circular neoprene gasket will be installed on the end of each pipe for a total of 24".

Helically corrugated pipe shall have either continuously welded seams or have lock seams or have lock seams with internal caulking or a neoprene bead.

Bedding - The pipe shall be firmly and uniformly bedded throughout its entire length. Where rock or soft, spongy or other unstable soil is encountered, all such material shall be removed and replaced with suitable earth compacted to provide adequate support.

Backfilling shall conform to "Structure Backfill".

Other details (anti-seep collars, valves, etc.) shall be as shown on the drawings.

Reinforced Concrete Pipe - All of the following criteria shall apply for reinforced concrete pipe.

Materials - Reinforced concrete pipe shall have bell and spigot joints with rubber gasket and shall equal or exceed ASTM Designation C-361. An approved equivalent is AWWA specification C-302.

Bedding - All reinforced concrete pipe conduits shall be laid in a concrete bedding for their entire length. This bedding shall consist of high slump concrete placed under the pipe and up the sides of the pipe at least 10% of its outside diameter with a minimum thickness of 3 inches, or as shown on the drawings.

Laying pipe - Bell and spigot pipe shall be placed with the bell end upstream. Joints shall be made in accordance with recommendations of the manufacturer of the material. After the joints are sealed for the entire line, the bedding shall be placed so that all spaces under the pipe are filled. Care shall be exercised to prevent any deviation from the original line and grade of the pipe. The first joint must be located within 2 feet from the riser.

Backfilling shall conform to "Structure Backfill".

Other details (anti-seep collar, valves, etc.) shall be as shown on the drawings.

Polyvinyl Chloride (PVC) Pipe - All of the following criteria shall apply for polyvinyl chloride (PVC) pipe.

Materials - PVC pipe shall be PVC-1120 or PVC-1220 conforming to ASTM D-1785 or ASTM D-2241.

Joints and connections to anti-seep collars shall be completely watertight.

Bedding - The pipe shall be firmly and uniformly bedded through out its entire length. Where rock or soft, spongy or other unstable soil is encountered, all such material shall be removed and replaced with suitable earth compacted to provide adequate support.

CONCRETE :

Concrete shall meet the requirements of Maryland Department of Transportation, State Highway Administration Standard Specification for Construction and Materials, Section 608, Mix No. 3.

ROCK RIPRAP :

All rock shall be dense, sound, and free from cracks, seams, and other defects conducive to accelerated weathering. The rock fragments shall be angular to subrounded in shape. The least dimension of an individual rock fragment shall be not less than one third the greatest dimension of the fragments.

The rock shall have the following properties :

1. Bulk specific gravity (saturated surface-dry basis) not less than 2.5.
2. Absorption not more than three percent.
3. Soundness: Weight loss in five cycles not more than 20 percent when sodium sulfate is used.

Bulk specific gravity and absorption shall be determined according to ASTM C 127. The test for soundness shall be performed according to ASTM C 88.

The riprap shall be placed to the required thickness in one operation. The rock shall be delivered and placed in a manner that will insure the riprap in place shall be reasonable homogeneous with the larger uniformly distributed and firmly in contact one to another with the smaller rock filling the voids between the larger rocks. Filter cloth shall be under all riprap and shall meet the requirements of Maryland Department of Transportation, State Highway Administration for Construction and Materials, Section 919.12.

CARE OF WATER DURING CONSTRUCTION:

All work on permanent structures shall be carried out in areas free from water. The Contractor shall construct and maintain all temporary dikes, levees, cofferdams, drainage channels and stream diversions necessary to protect the areas to be occupied by the permanent works the contractor shall also furnish, install, operate, and maintain all necessary pumping and other equipment required for removal of water from the various parts of the work and for maintaining the excavations, foundation, and other parts of the work free from water as required by the Engineer for constructing each part of the work. After having served their purpose, all temporary protective works shall be removed or leveled and graded to the extent required to prevent obstruction in any degree whatsoever of the flow of water to the spillway or outlet works and so as not to interfere in any way with the operation or maintenance of the structure. Stream diversions shall be maintained until the full flow can be passed through the permanent works. The removal of water from the required excavation and the foundation shall be accomplished in a manner and to the extent that will maintain stability of the excavated slopes and bottom of required excavations and will allow satisfactory performance of all construction operations. During the placing and compacting of material in required excavations, the water level at the location being refilled shall be maintained below the bottom of the excavation at such locations which may require draining the water to sumps from which the water shall be pumped.

STABILIZATION :

All borrow areas shall be graded to provide proper drainage and left in a slight condition. All exposed surfaces of the embankment, spillway, spoil and borrow areas, and berms shall be stabilized by seeding, liming, fertilizing and mulching in accordance with the Maryland Soil Conservation Service Standards and Specifications for Critical Area Planting (MD-342) or as shown on the accompanying drawings.

EROSION AND SEDIMENT CONTROL :

Construction operation will be carried out in such a manner that erosion will be controlled and water and air pollution minimized. State and local laws concerning pollution abatement will be followed. Construction plans shall detail erosion and sediment control measures to be employed during the construction process.

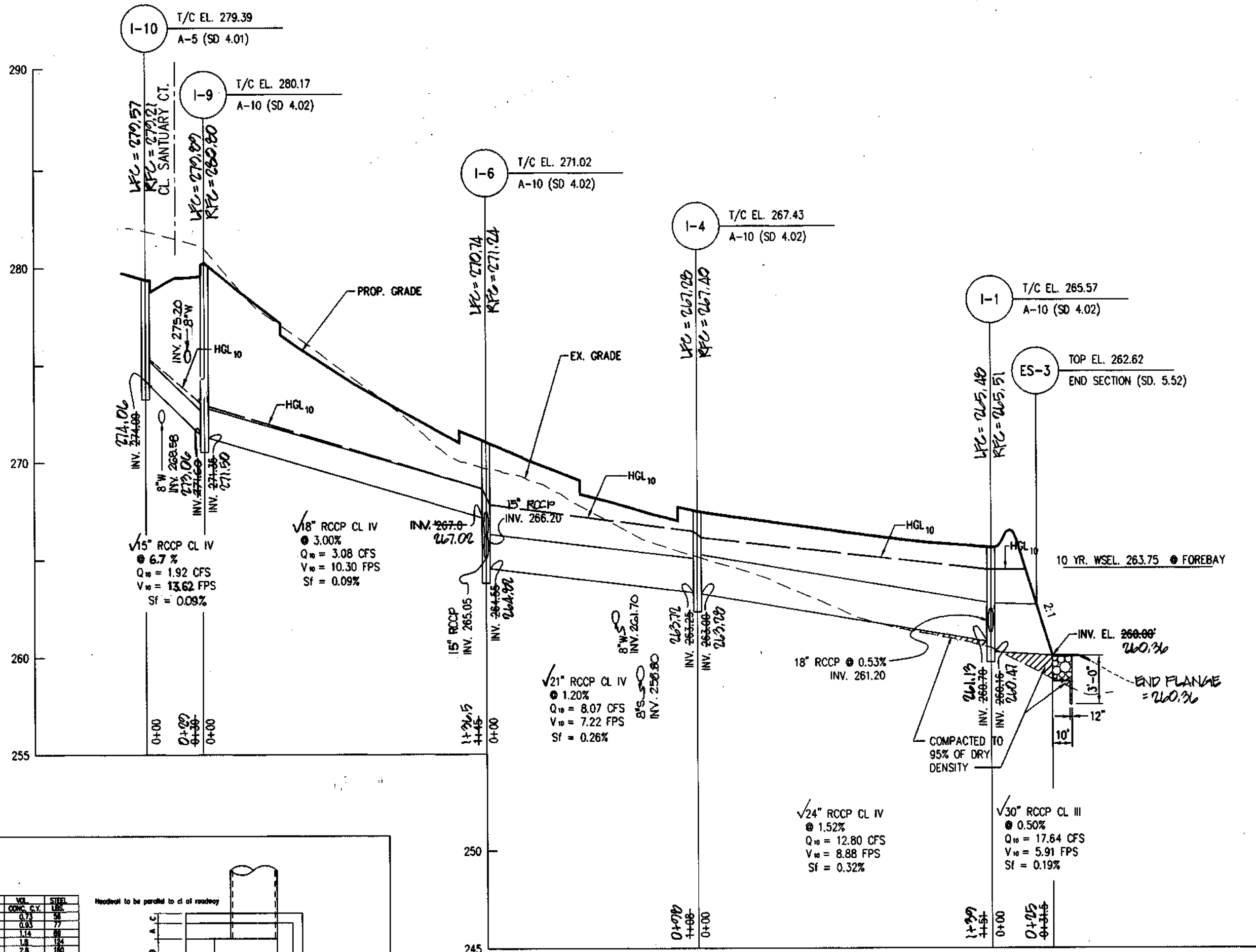

SCALE : 1" = 50' HOR.
1" = 5' VER.

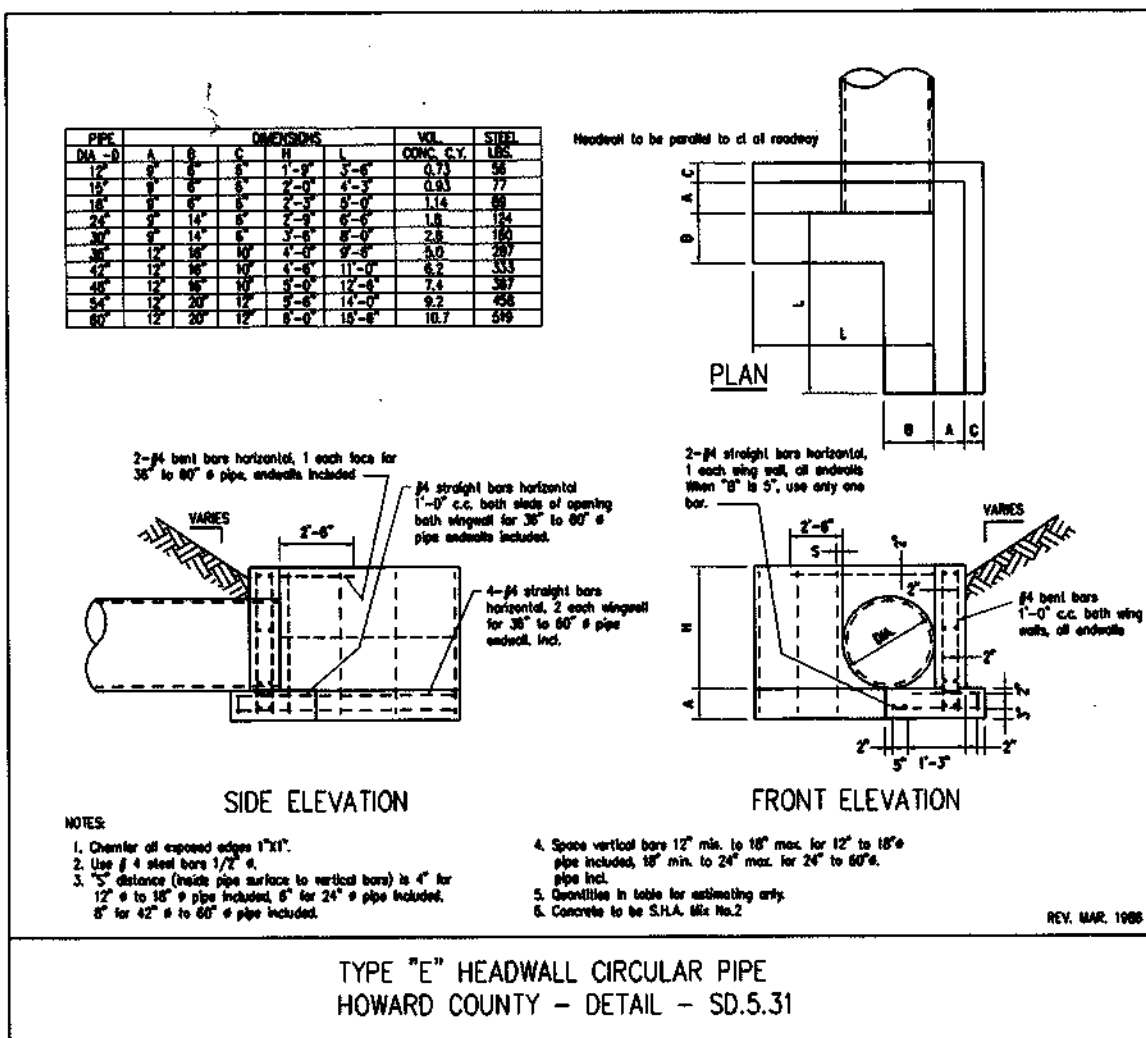

TYPE "E" HEADWALL CIRCULAR PIPE
HOWARD COUNTY - DETAIL - SD-5.31

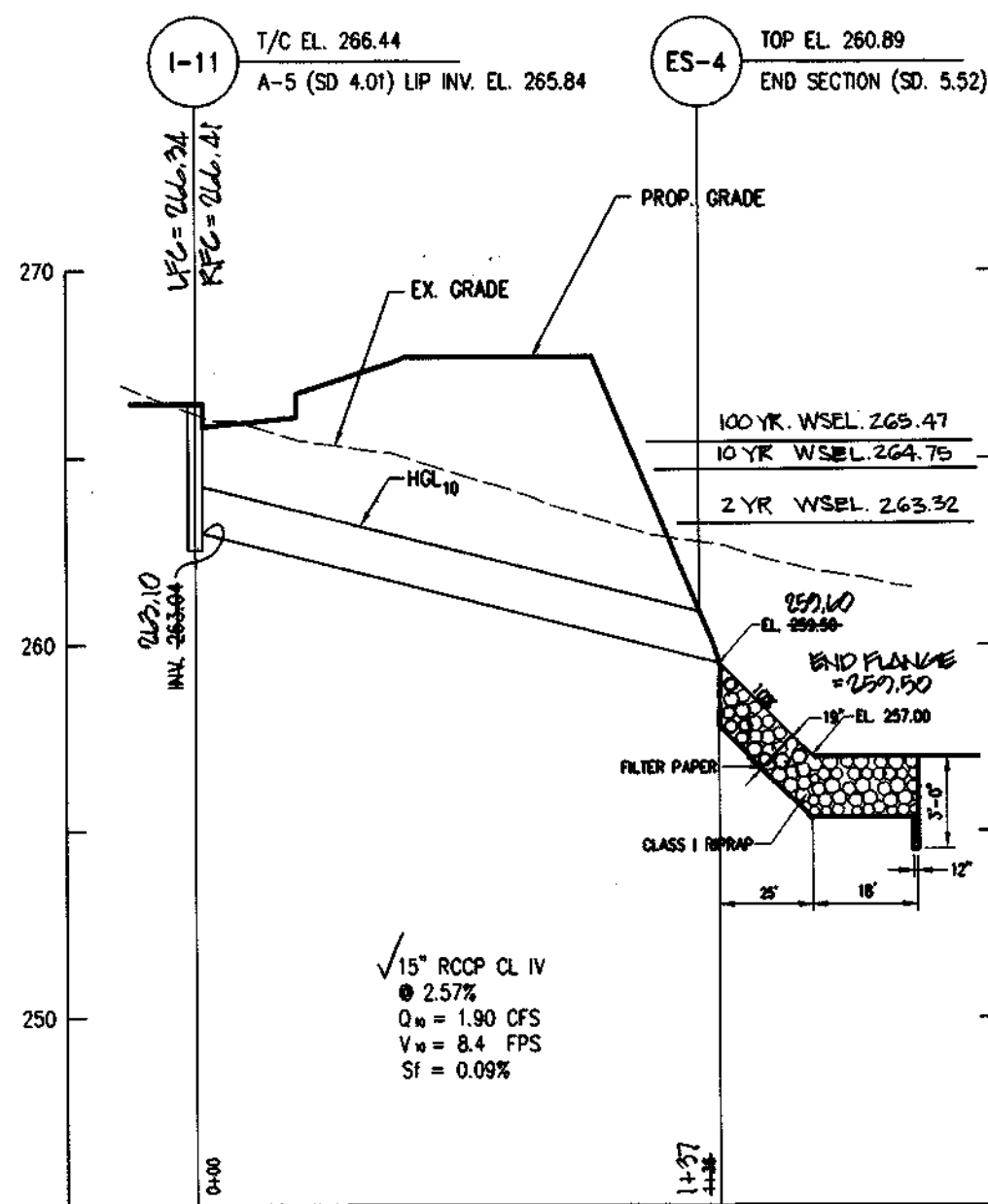

SCALE : 1" = 50' HOR.
1" = 5' VER.

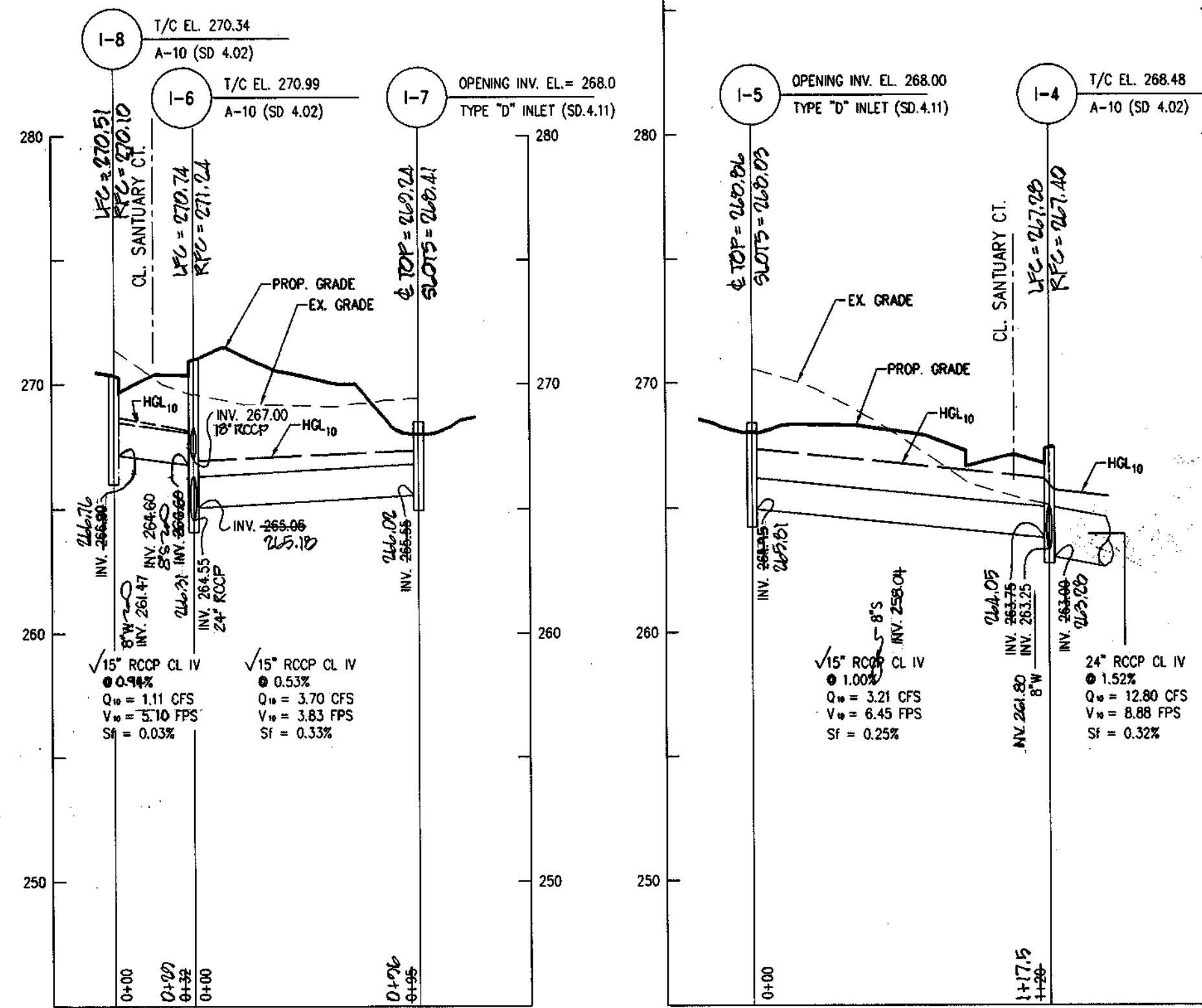

SCALE : 1" = 50' HOR.
1" = 5' VER.

SCALE : 1" = 50' HOR.
1" = 5' VER.



NUMBER	TYPE	INV. IN	INV. OUT	TOP EL.	REMARKS	LOCATION
I-1	CURB INLET	260.70	261.20	260.16	HO. CO. SD.4.02	STA 4+98.74, 24' R
I-2	CURB INLET	261.85	261.70	266.14	HO. CO. SD.4.02	STA 7+50.72, 25' R
I-3	TYPE D	262.25	262.25	266.80	HO. CO. SD.4.11	N 8959401.36A, E 187282.77I
I-4	CURB INLET	263.25	263.75	266.48	HO. CO. SD.4.02	STA 14+3.1, 14' R
I-5	TYPE D	263.25	263.75	266.80	HO. CO. SD.4.11	N 8959401.36A, E 187282.77I
I-6	CURB INLET	267.00	266.40	266.99	HO. CO. SD.4.02	STA 4+43.53, 14' R
I-7	TYPE D	268.95	268.95	268.20	HO. CO. SD.4.11	N 8959401.36A, E 187282.77I
I-8	CURB INLET	268.30	268.60	272.34	HO. CO. SD.4.02	STA 14+28.72, 14' R
I-9	CURB INLET	271.40	271.95	280.17	HO. CO. SD.4.02	STA 3+00.00, 14' R
I-10	TYPE A-5	278.64	278.39	278.39	HO. CO. SD.4.01	STA 3+13.34, 14' L
I-11	TYPE A-5	282.99	282.99	286.44	HO. CO. SD.4.01	STA 14+99.35, 14' L
ES-1	END SECTION	260.00	260.00	260.00	HO. CO. SD.5.52	N 8959401.36A, E 187282.77I
ES-2	END SECTION	260.00	260.00	260.00	HO. CO. SD.5.52	N 8959401.36A, E 187282.77I
ES-3	END SECTION	260.00	260.00	260.00	HO. CO. SD.5.52	N 8959401.36A, E 187282.77I
ES-4	END SECTION	260.00	260.00	260.00	HO. CO. SD.5.52	N 8959401.36A, E 187282.77I
S-1	MOD. A-10	267.00	267.00	267.00	N 8959401.36A, E 187282.77I	
S-2	MOD. A-10	260.00	260.00	260.00	N 8959401.36A, E 187282.77I	

NO.	DATE	REVISION
1	10-11-97	FOR REVISION PER AG-BUILD CONNECTIONS

APPROVED : HOWARD COUNTY DEPARTMENT OF PLANNING AND ZONING	
<i>[Signature]</i>	7/21/97 DATE
APPROVED : HOWARD COUNTY DEPARTMENT OF PUBLIC WORKS	
<i>[Signature]</i>	7-11-97 DATE
PROJECT NAME : THE SANCTUARY	
P-97-07 - A SUBDIVISION OF PARCELS 164,165,166,564,565 & 566	
S-94-25 FIRST ELECTION DISTRICT TAX MAP #37	
HOWARD COUNTY, MARYLAND	
TITLE : STORM DRAIN PROFILE	DEVELOPER : BUNRATTY INVESTMENTS LTD. P.O. BOX 999 COLUMBIA, MARYLAND 21044
PREPARED BY : AMERICAN LAND DEVELOPMENT AND ENGINEERING INC.	OWNER : MR. ROBERT O'LEXY 6693 OLD WATERLOO ROAD BALTIMORE, MARYLAND 20794
DES. : D.C.W.	OWNER : BUNRATTY INVESTMENTS LTD. P.O. BOX 999 COLUMBIA, MARYLAND 21044
DRW. : AVG	OWNER : MR. GLOIRA M. DIETRICH 6715 OLD WATERLOO ROAD BALTIMORE, MARYLAND 20794
CHK. : D.C.W.	SCALE : 1" = 50'
DATE : 6-18-97	SHEET : 5 OF 7

TEST PIT EXPLORATION
Geo-Technology Associates
Annapolis Junction, Maryland

Job Name: Sanctuary Property Test Pit: B-1
Job Number: 21411-02 Total Depth: 12.0' Water First: 3.5'-2.4'
Date: 5-5-94 Elevation: 161 (topsoil) Encountered: 5.0'
Inspector: M. Boyd Equipment: Case 590 After: 1 hrs: 7.0' Turbo

DEPTH	DESCRIPTION	COMMENTS
2'	Topsoil & roots	24" topsoil
4'	Gray-orange, very moist, plastic silt & clay, little sand (ML) USDA; clay loam	Water entering test pit at 2.0' and 7.5'
5'	Gray-orange, moist sand, little clay (SC) USDA; sandy clay loam	Caved from 4.0' to 8.0' at completion
9'		
10'	Gray, very moist, silty clay (CH) USDA; clay	
12'	B.O.H. - 12.0'	
15'		
20'		
25'		

TEST PIT EXPLORATION
Geo-Technology Associates
Annapolis Junction, Maryland

Job Name: Sanctuary Property Test Pit: B-2
Job Number: 21411-02 Total Depth: 11.0' Water First: 5'-5-24
Date: 5-5-94 Elevation: 158 (topsoil) Encountered: 2.0'
Inspector: M. Boyd Equipment: Case 590 After: 1 1/4 hrs: 2.0' Turbo

DEPTH	DESCRIPTION	COMMENTS
2'	Topsoil	24" topsoil
5'	Brown-orange, very moist silty clay (CH) USDA; clay	Little water seeping from topsoil
6'		
10'	Orange, wet, silt and clay, little sand, trace rock fragments (CH/ML) USDA; clay	Water entering at 9.0'
11'		
15'		
20'		
25'		

TEST PIT EXPLORATION
Geo-Technology Associates
Annapolis Junction, Maryland

Job Name: Sanctuary Property Test Pit: B-3
Job Number: 21411-02 Total Depth: 12.0' Water First: 5'-5-24
Date: 5-5-94 Elevation: 158 (topsoil) Encountered: 7.0'
Inspector: M. Boyd Equipment: Case 590 After: 0.5 hrs: 7.0' Turbo

DEPTH	DESCRIPTION	COMMENTS
2'	Topsoil	18" topsoil
5'	Green-gray, very moist clay (CH) USDA; clay	Water at 7.0'
10'	Orange, gray, very moist, to wet, clayey silt, little sand (MH) USDA; clay	
12'	Orange, wet, sandy silt, trace rock fragments (ML) USDA; sandy loam	
14'	B.O.H. - 12.0'	

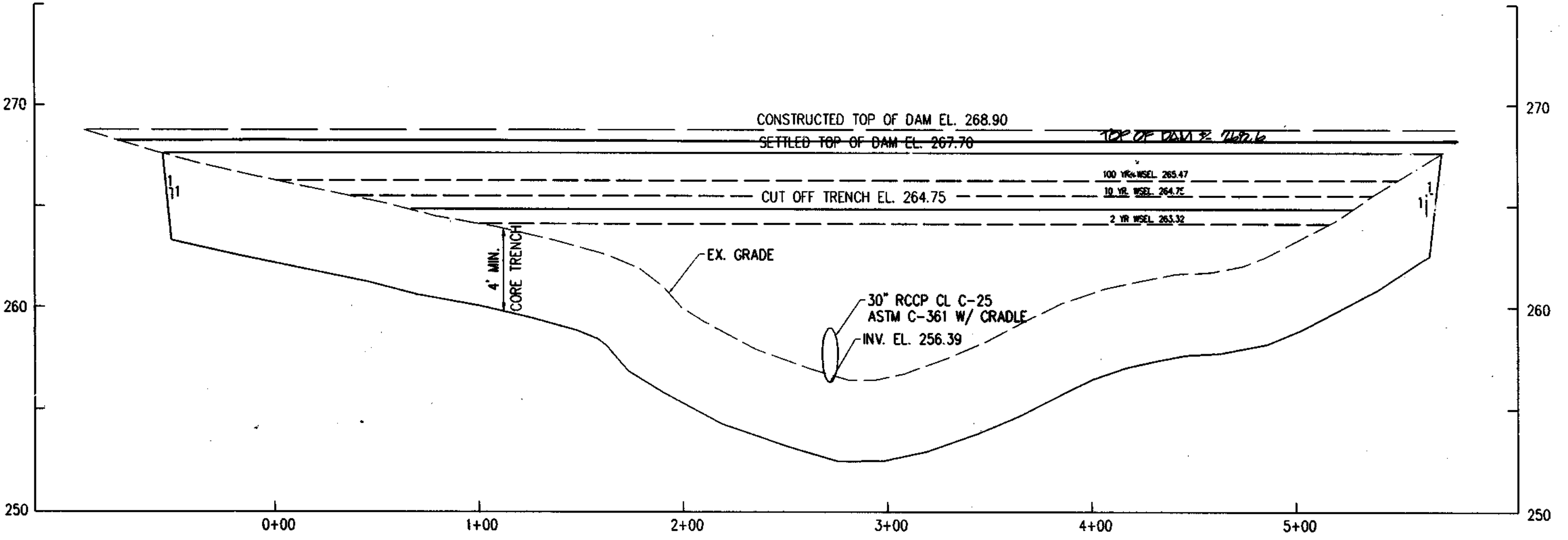
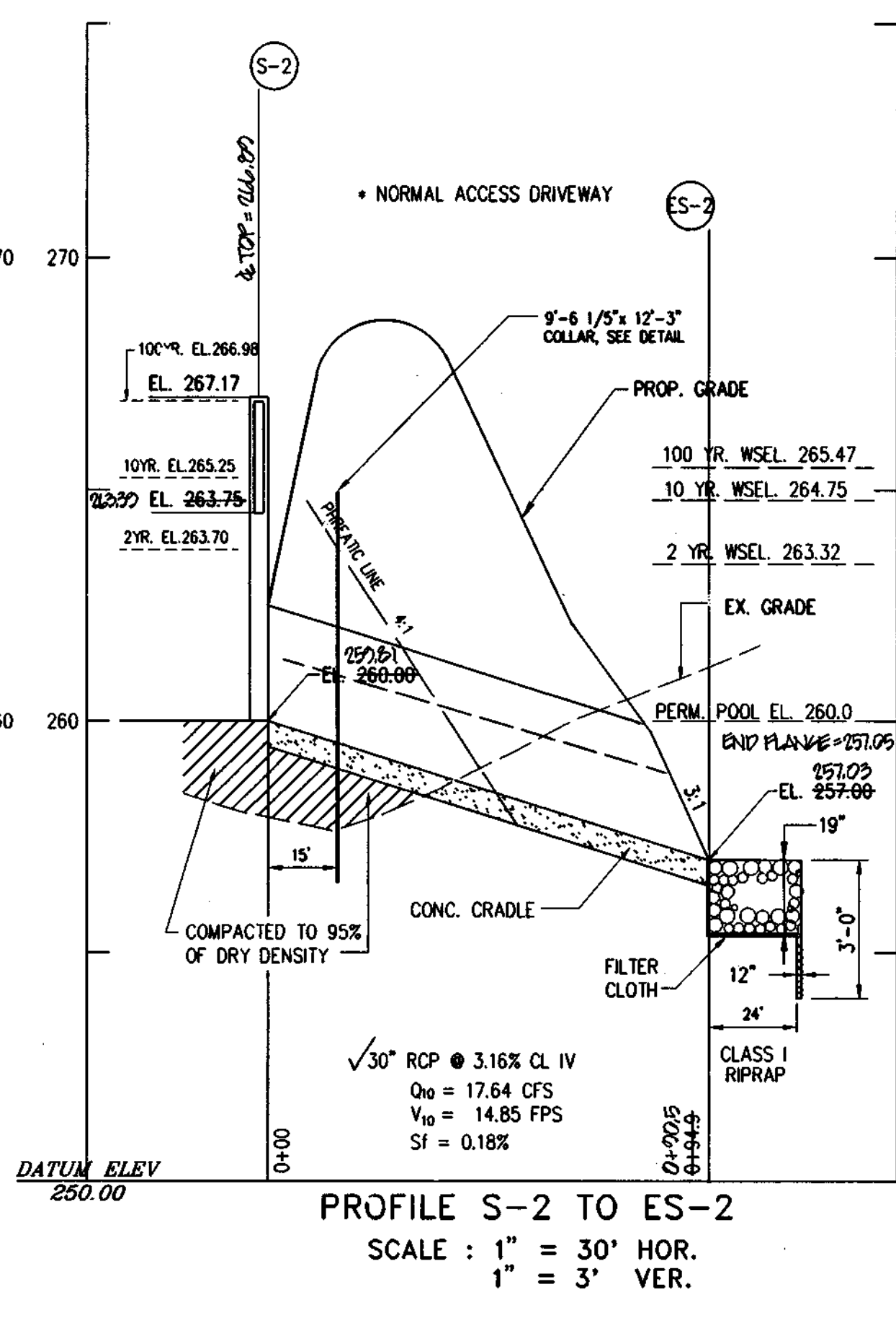
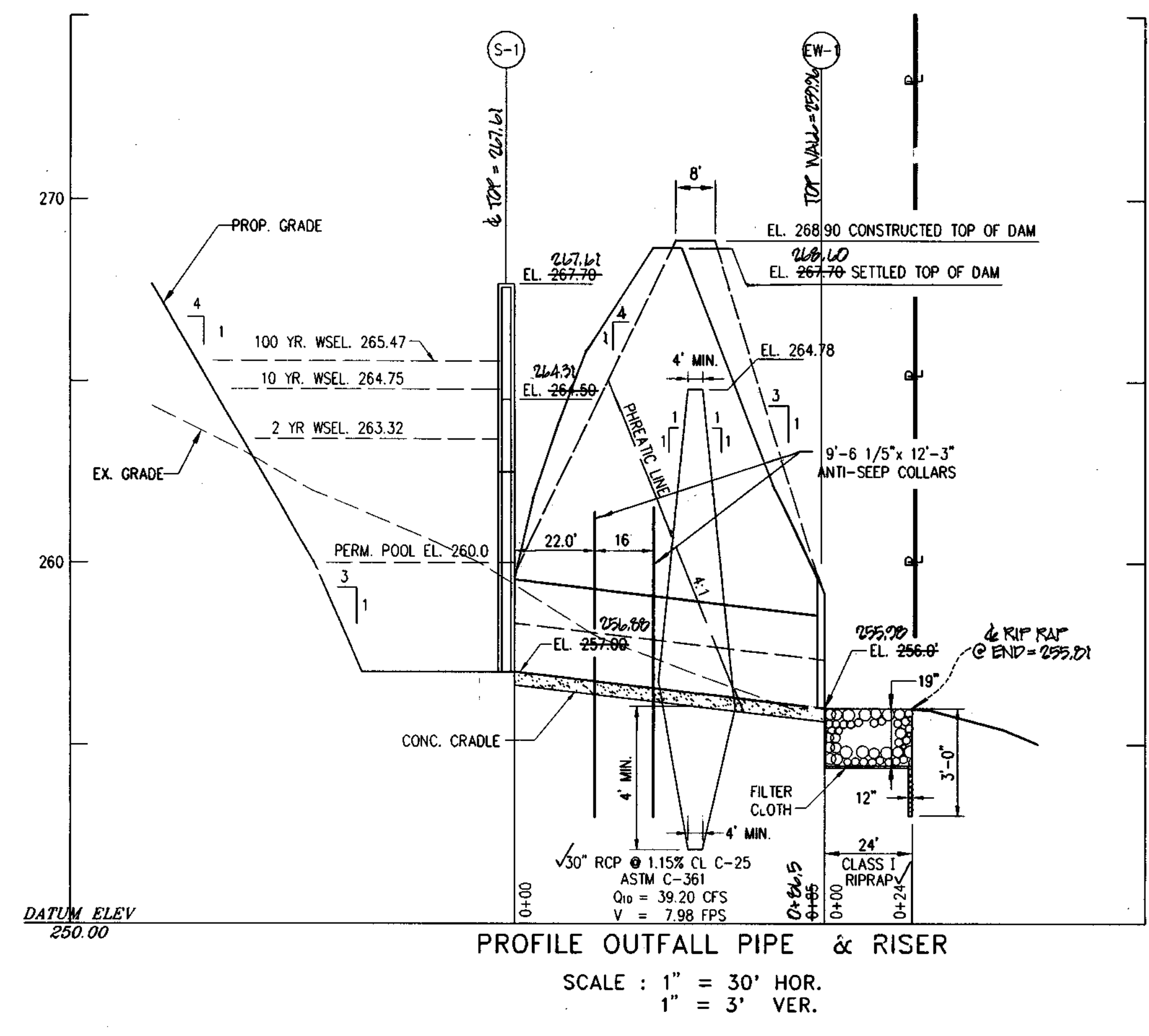

OPERATION, MAINTENANCE AND INSPECTION

INSPECTION OF THE POND(S) SHOWN SHALL BE PERFORMED AT LEAST ANNUALLY, IN ACCORDANCE WITH THE CHECKLIST AND REQUIREMENTS CONTAINED WITHIN USDA, SCS STANDARDS AND SPECIFICATIONS FOR PONDS (NO. 378). THE POND OWNER(S) AND HEIRS, SUCCESSORS, OR ASSIGNS SHALL BE RESPONSIBLE FOR THE SAFETY OF THE POND AND THE CONTINUED OPERATION, SURVEILLANCE, INSPECTION AND MAINTENANCE THEREOF. THE POND OWNER(S) SHALL PROMPTLY NOTIFY THE SOIL CONSERVATION DISTRICT OF ANY UNUSUAL OBSERVATIONS THAT MAY BE INDICATION OF DISTRESS SUCH AS EXCESSIVE SEEPAGE, TURBID SEEPAGE, SLIDING OR SLUMPING.

- STORMWATER MANAGEMENT OPERATIONS & MAINTENANCE SCHEDULE (FOR HOME OWNER'S ASSOCIATION)**
- TOP AND SIDE SLOPES OF THE EMBANKMENT SHALL BE MOVED A MINIMUM OF TWO (2) TIMES A YEAR, ONCE IN JUNE AND ONCE IN SEPTEMBER. OTHER SIDE SLOPES, THE BOTTOM OF THE POND AND MAINTENANCE ACCESS SHOULD BE MOWED AS NEEDED.
 - DEBRIS AND LITTER NEXT TO THE OUTLET STRUCTURE SHALL BE REMOVED DURING REGULAR MOWING OPERATIONS AND AS NEEDED.
 - WHEN DEEMED NECESSARY FOR AESTHETIC REASON, SEDIMENT SHOULD BE REMOVED FROM THE POND, THE FOREBAY @ S-2 AND @ I-1. APPROVAL OF THE DEPARTMENT OF PUBLIC WORKS IS REQUIRED.

POND SUMMARY TABLE

STORM FREQ.	D.A. (AC.)	SITE RELEASE RATE (CFS) (DESIGN)	I.N.O. (CFS)	O.U.T. (CFS)	WSEL IN POND	STORAGE IN POND (AC. FT.)	O OUT SITE
2	1.65	9.5	18.5	4.9	263.32	6.0	6.0
10	6.65	24.0	33.6	15.4	264.75	16.8	16.8
100	6.65	42.1	50.0	35.6	265.47	40.8	40.8

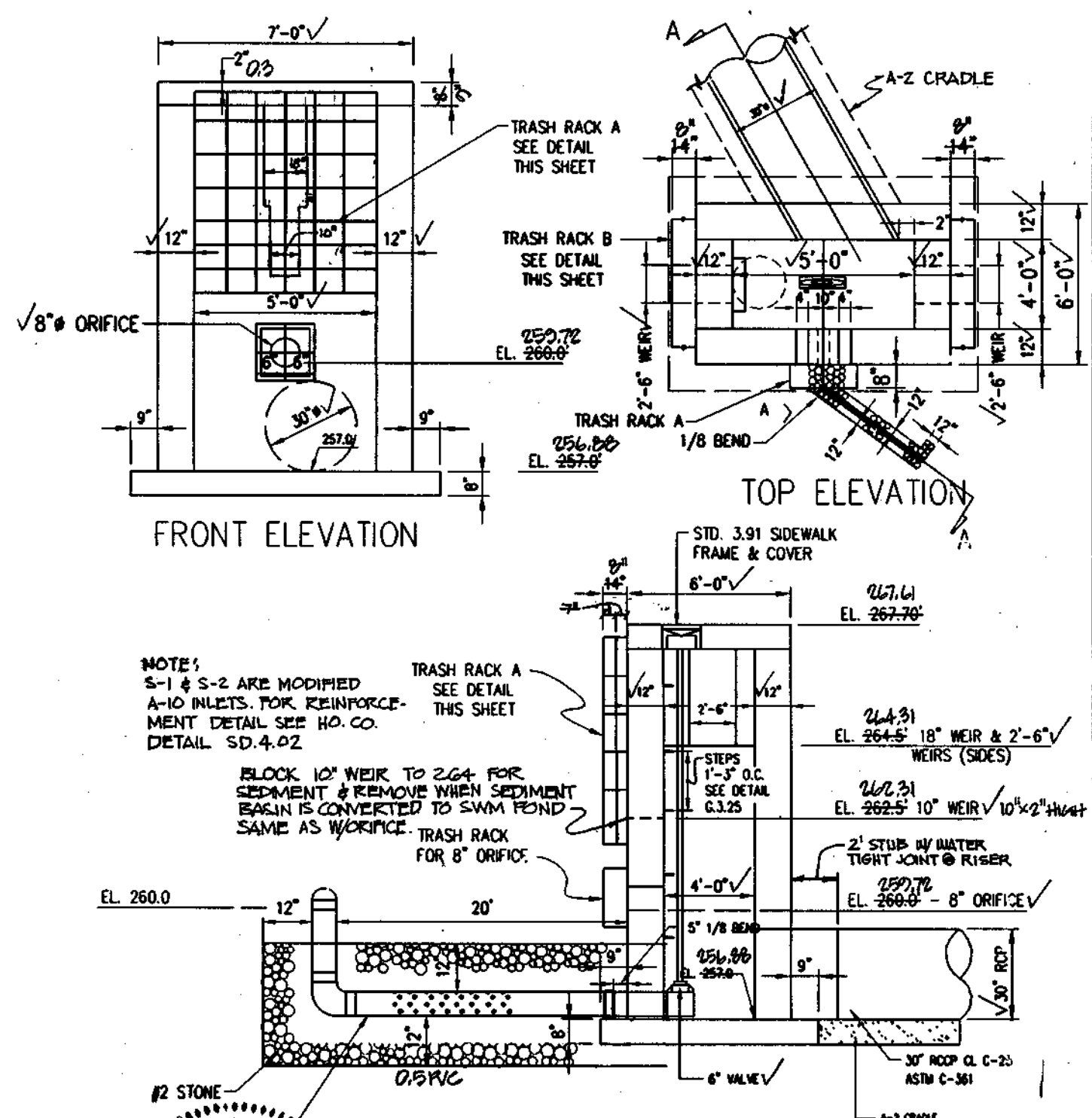
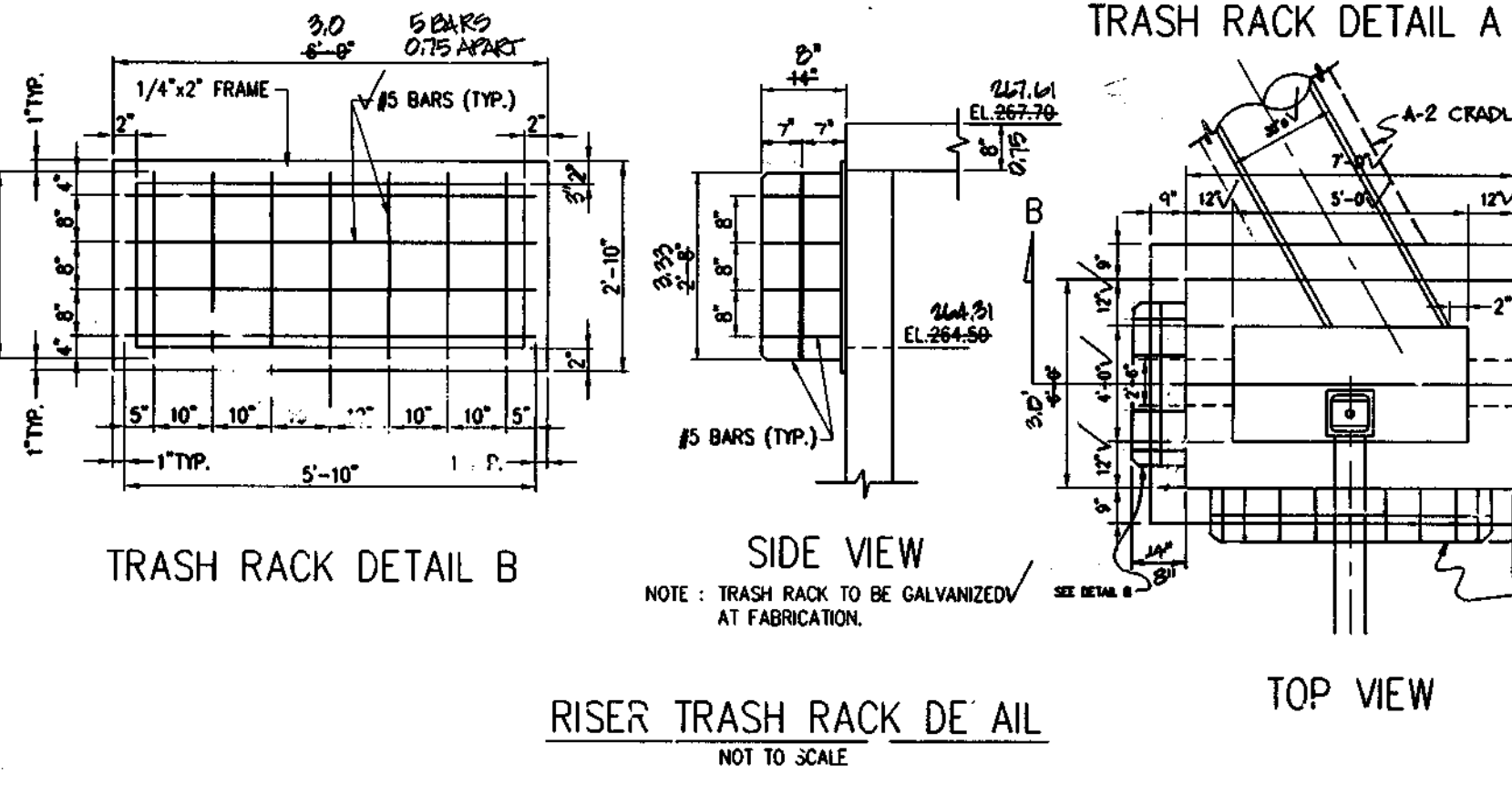
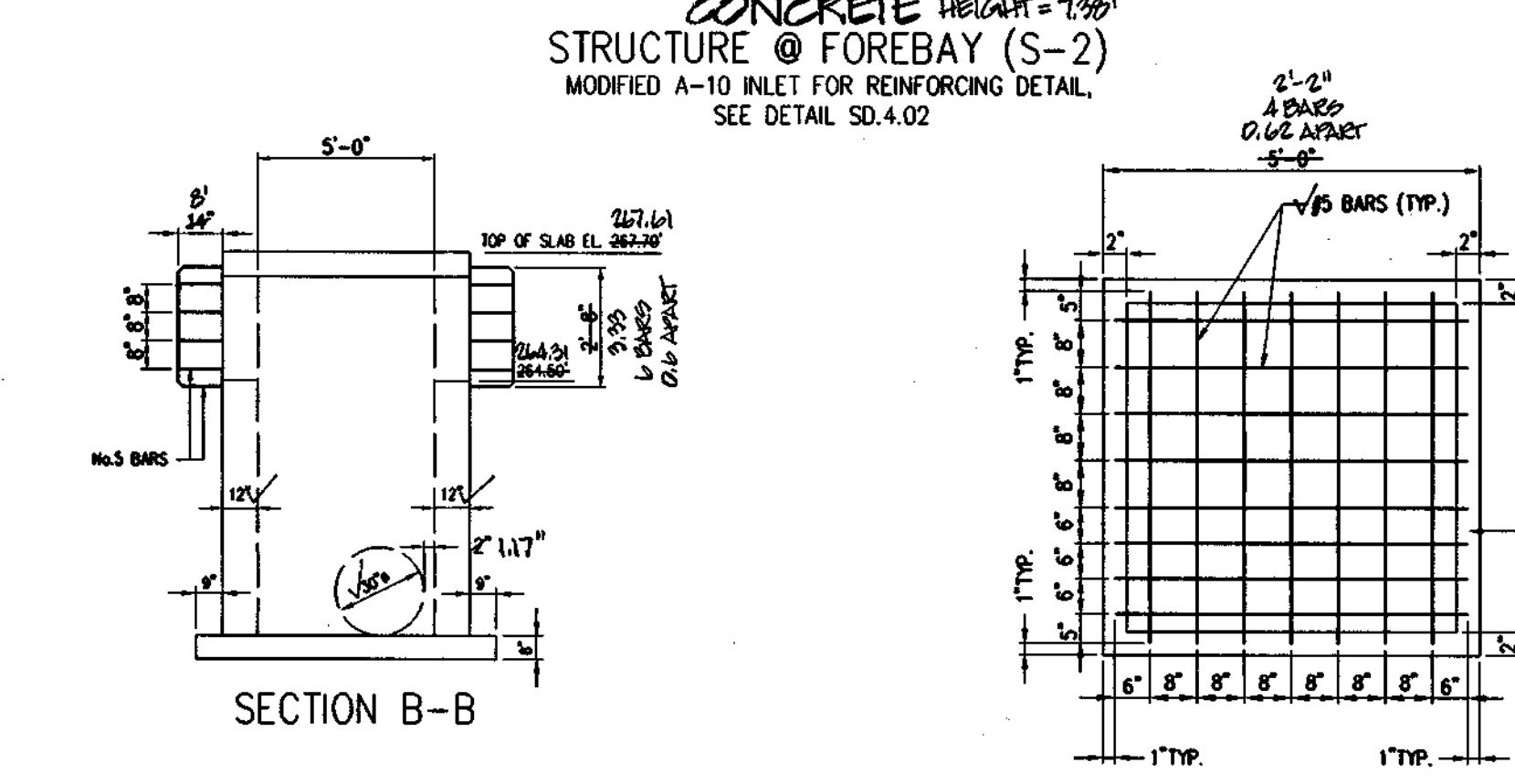
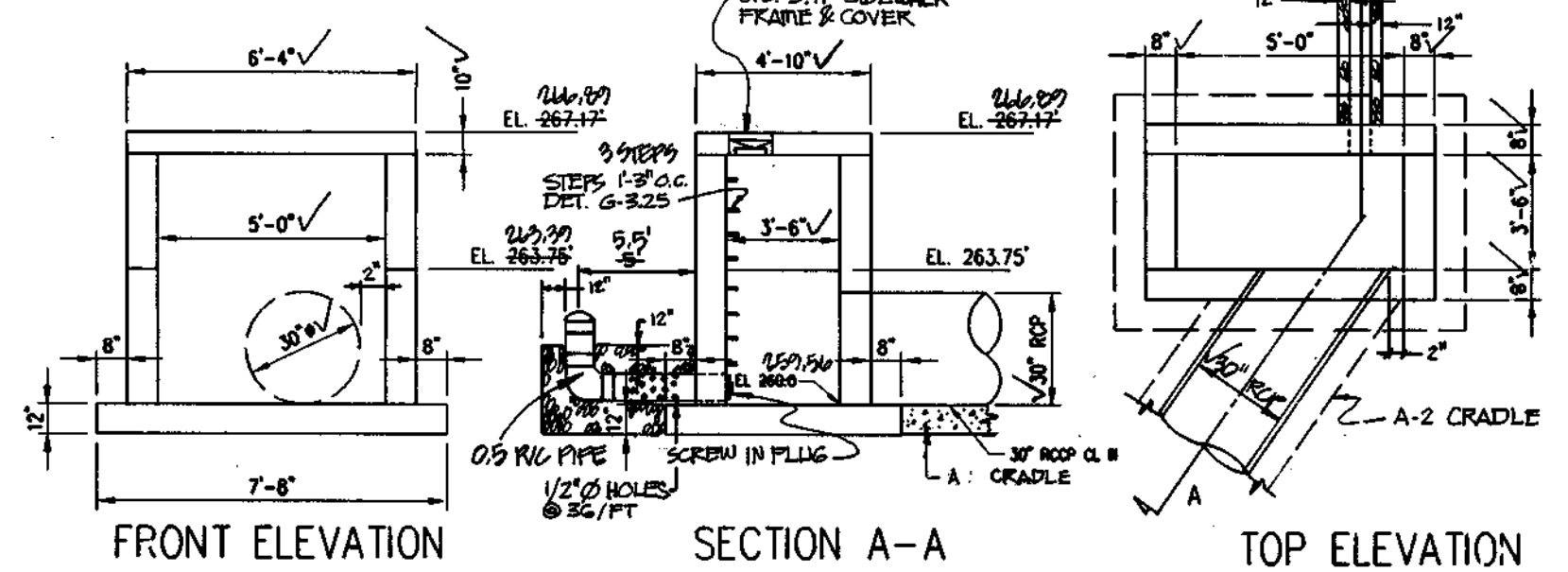
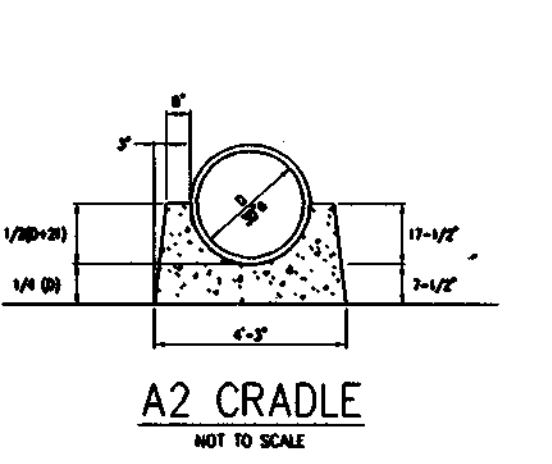

CONCRETE RISER STRUCTURE @ SWM POND (S-1)
MODIFIED A-10 INLET FOR REINFORCING DETAIL, SEE DETAIL SD.4.02

APPROVED: HOWARD COUNTY DEPARTMENT OF PLANNING AND ZONING
DATE: 7/17/97

APPROVED: HOWARD COUNTY DEPARTMENT OF PUBLIC WORKS
DATE: 7-11-97

PROJECT NAME: THE SANCTUARY
LOTS 1-61
A SUBDIVISION OF PARCELS 164,165,166,564,565 & 566
FIRST ELECTION DISTRICT TAX MAP #37
HOWARD COUNTY, MARYLAND.

TITLE: STORMWATER MANAGEMENT POND & DETAIL

DEVELOPER: BUNRATTY INVESTMENTS LTD.
P.O. BOX 999
COLUMBIA, MARYLAND 21044

OWNER: MR. ROBERT O'LEVEY
6693 OLD WATERLOO ROAD
BALTIMORE, MARYLAND 20794

OWNER: BUNRATTY INVESTMENTS LTD.
P.O. BOX 999
COLUMBIA, MARYLAND 21044

OWNER: MR. CLORIA M. DETRICH
6719 OLD WATERLOO ROAD
BALTIMORE, MARYLAND 20794

PREPARED BY: AMERICAN LAND DEVELOPMENT AND ENGINEERING INC.
671-A MAIN STREET
LAUREL, MARYLAND 20707
WASH. (301) 853-1221
BALT. (301) 890-3039

DES.: D.C.W. **JOB:**
DRW.: AVG **PROJ.:** SWMPOND.WG **SCALE:**
CHK.: D.C.W. **DATE:** 6-18-97 **1" = 50'** **SHEET 6 OF 7**

DEVELOPER'S/BUILDER'S CERTIFICATE

"I/We certify that all development and/or construction will be done according to these plans, and that any responsible involved in the construction project will have a Certificate of Attendance at a Department of the Environment Approved Training Program for the Control of Sediment and Erosion before beginning the project. I also engage a registered professional engineer to supervise pond construction and provide the Howard Soil Conservation District with an "as-built" plan of the pond within 30 days of completion. I also authorize periodic on-site inspections by the Howard Soil Conservation District."

ENGINEER'S CERTIFICATE

"I certify that this plan for pond construction, erosion and sediment control represents a practical and workable plan based on my knowledge of the site conditions. This plan was prepared in accordance with the requirements of the Howard Soil Conservation District. I have notified the developer that he/she must engage a registered professional engineer to supervise pond construction and provide the Howard Soil Conservation District with an "as-built" plan of the pond within 30 days of completion."

These plans have been reviewed for the Howard Soil Conservation District and meet the technical requirements for the Small Pond Construction, Soil Erosion and Sediment Control.
U.S. Natural Resources Conservation Service
Date: 07-03-97

These plans for Small Pond Construction, Soil Erosion and Sediment Control meet the requirements of the Howard County Soil Conservation District.
Howard County Soil Conservation District
Date: 7-17-97

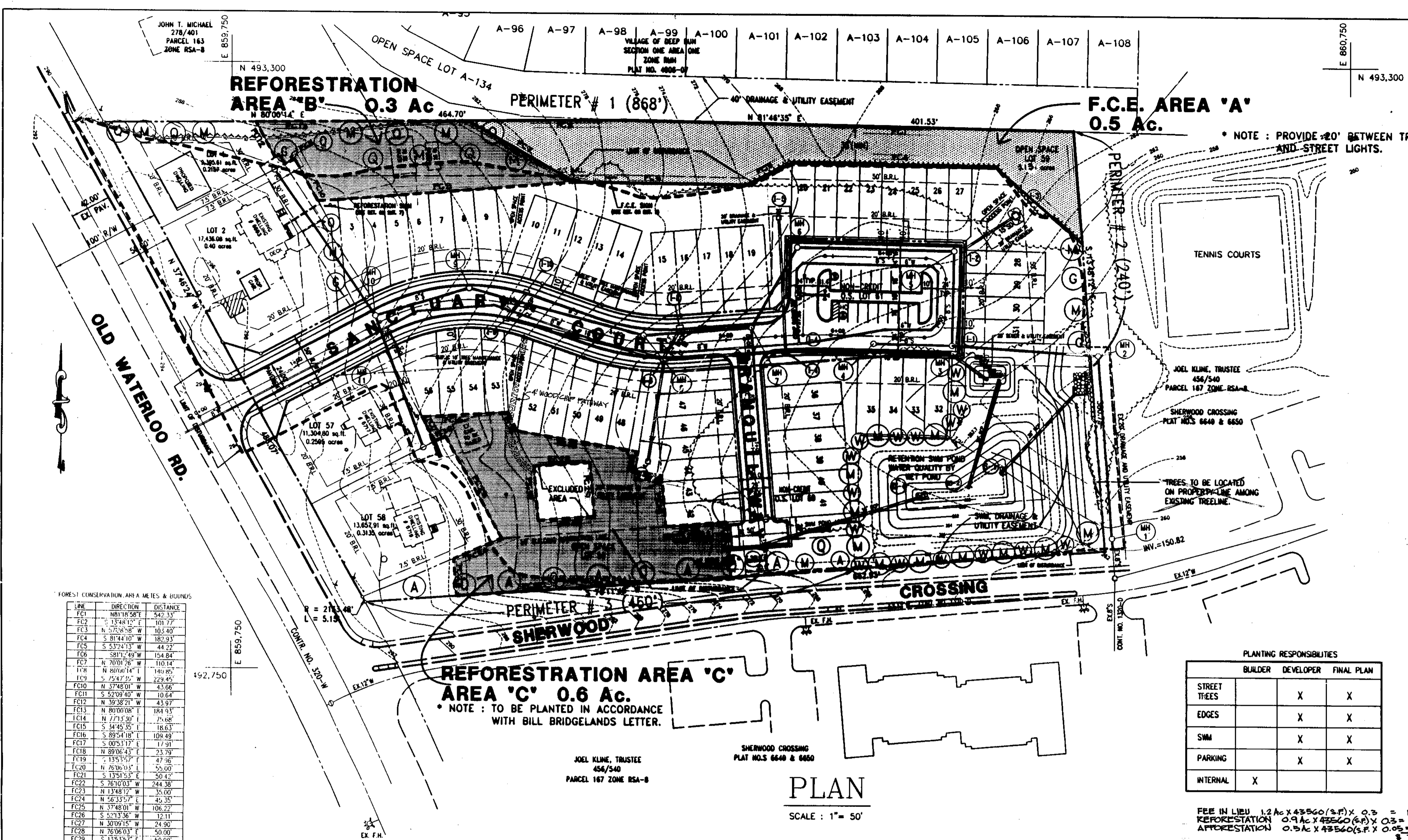

SWM AREA LANDSCAPE		PERIMETER LANDSCAPE EDGE			
CATEGORY	ADJACENT TO	ADJACENT TO	ADJACENT TO	ADJACENT TO	ADJACENT TO
LANDSCAPE TYPE	ROADWAY	THRESHOLD	THRESHOLD	THRESHOLD	THRESHOLD
LINEAR FEET OF ROADWAY PERIMETER	720	480	860	240	460
CREDIT FOR EXISTING VEGETATION (FEET, NO. LINEAR FEET) (EXCLUDING BOUNDARY OF ROADWAY)		0	0	0	0
CREDIT FOR SMALL FENCE OR BERM (FEET, NO. LINEAR FEET) (EXCLUDING BOUNDARY OF ROADWAY)		0	0	0	0
NUMBER OF PLANTS REQUIRED	14	14	14	14	14
NUMBER OF PLANTS PROVIDED	14	14	14	14	14

QUANTITY	SYMBOL	BOTANICAL NAME	COMMON NAME	REMARKS
14	M	FRAXINUS PENNSYLVANICA 'MARSHALL'S SEEDLESS'	SEEDLESS ASH	
0	G	LIQUIDAMBAR STYRACIFLUA	SWEETGUM	
18	W	PINUS STROBUS	WHITE PINE	
0	B	PRINUS SPONTANEA	BLACK CHERRY	
0	A	PLATANUS ACERIFOLIA	LONDON PLANE TREE	
0	Q	QUERCUS BOREALIS RUBRA	NORTHERN RED OAK	

QUANTITY	SYMBOL	BOTANICAL NAME	COMMON NAME	REMARKS
40	R	LIRIODENDRON TULIPIFERA	TULIP POPLAR	
40	G	QUERCUS RUBRA	N. RED OAK	
25	T	ACER RUBRUM	RED MAPLE	
25	L	PRINUS SPONTANEA	BLACK CHERRY	
15	P	QUERCUS COCCINEA	SCARLET OAK	
30	D	CORNUS FLORIDA	DOGWOOD	

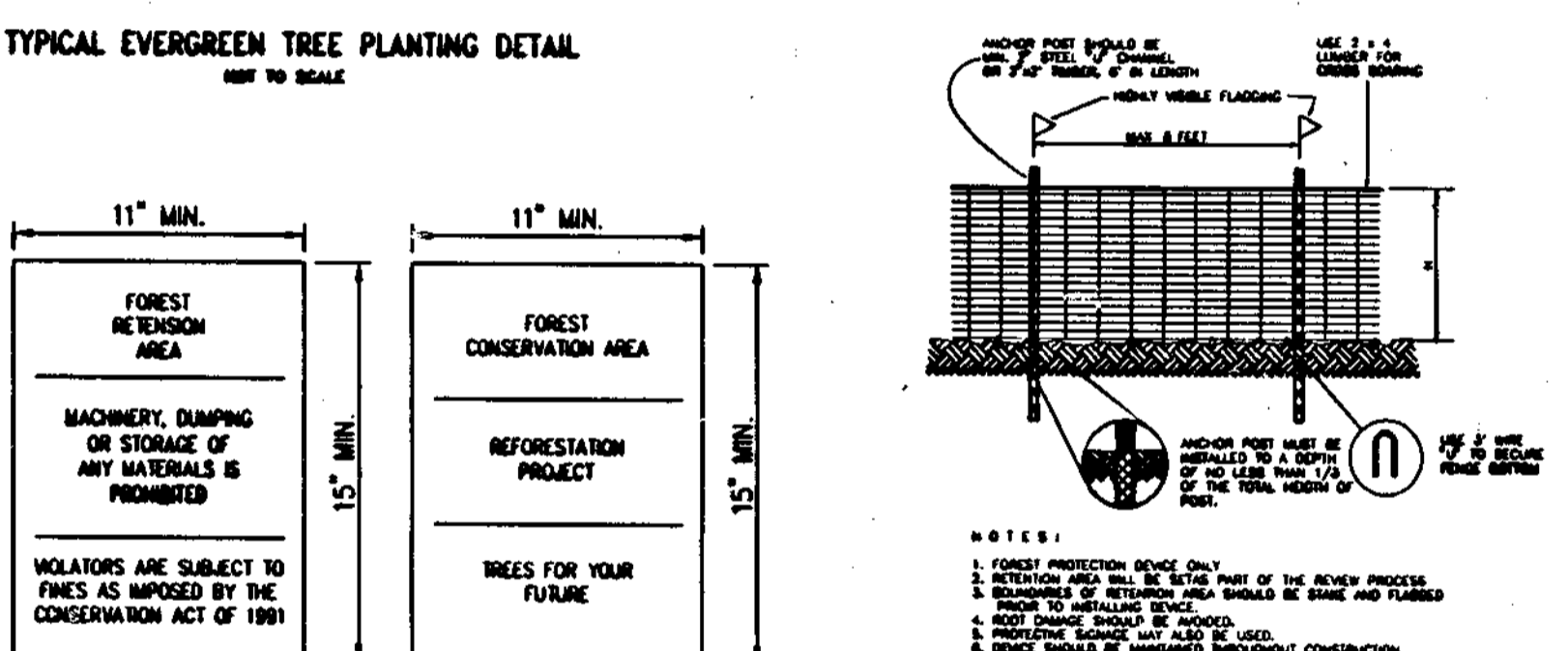
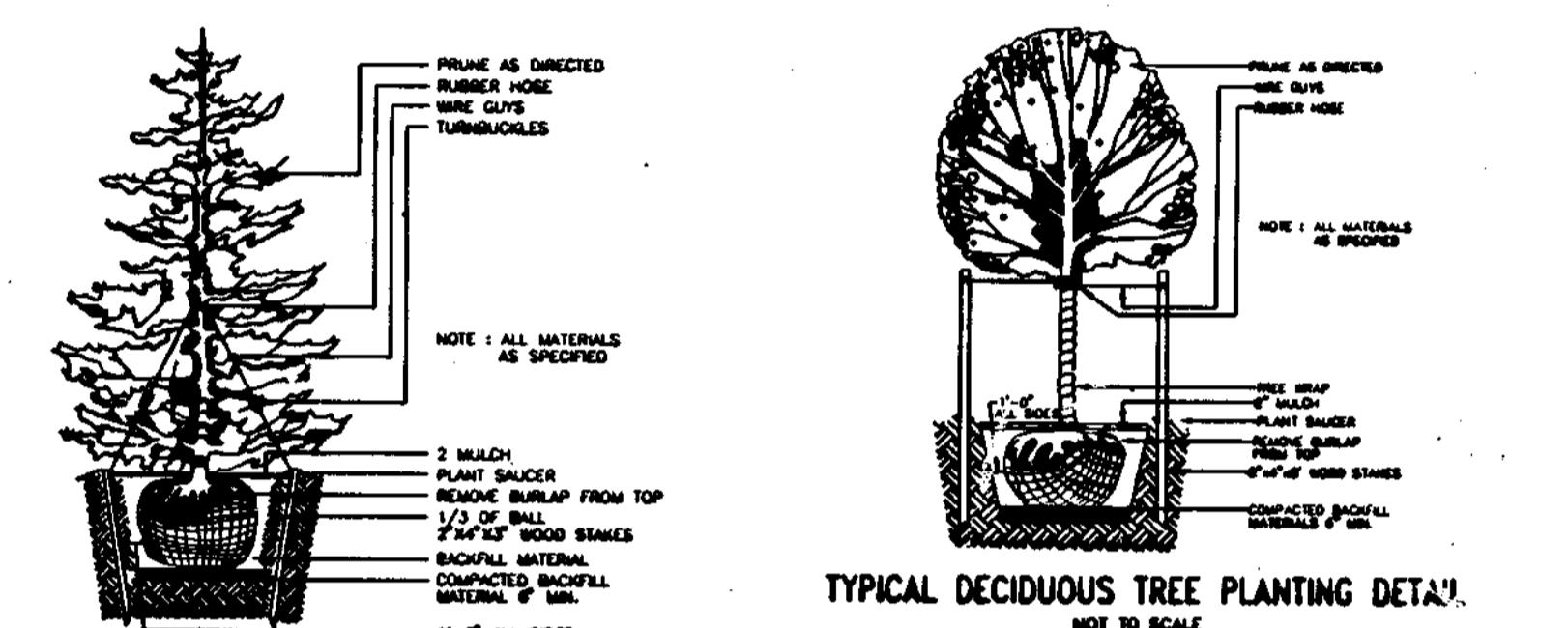

LINE	DIRECTION	DISTANCE
FC1	N 81°18'58"E	542.33'
FC2	S 13°48'12"E	101.77'
FC3	N 37°26'08"W	103.80'
FC4	S 81°44'10"W	182.93'
FC5	S 53°24'13"W	44.22'
FC6	S 81°17'49"W	154.84'
FC7	N 70°07'26"W	110.14'
FC8	N 80°16'14"E	140.89'
FC9	S 75°47'52"W	229.45'
FC10	N 37°48'01"W	43.66'
FC11	S 52°09'40"W	10.64'
FC12	N 39°38'27"W	43.97'
FC13	N 80°00'08"E	184.93'
FC14	N 77°15'30"E	71.68'
FC15	S 34°45'35"E	18.63'
FC16	S 89°54'18"E	109.49'
FC17	S 82°51'17"E	9.91'
FC18	N 89°06'43"E	23.79'
FC19	S 135°55'27"E	47.98'
FC20	N 76°16'05"E	55.00'
FC21	S 135°53'27"E	50.43'
FC22	S 76°10'03"W	244.98'
FC23	N 13°48'12"E	35.00'
FC24	N 56°33'57"E	40.35'
FC25	N 17°48'01"W	106.27'
FC26	S 52°13'36"W	12.11'
FC27	N 30°09'15"W	24.90'
FC28	N 76°06'03"E	50.00'
FC29	S 135°53'27"E	50.00'
FC30	S 76°09'15"W	50.00'
FC31	N 135°53'27"E	50.00'

THE SANCTUARY FOREST CONSERVATION PLAN
 Based on the Forest Conservation Worksheet results, 2.1 acres of reforestation are required in addition to retaining 0.8 acres of the existing forest (F.C.E. Area A). The reforestation area shown on the development plan total approximately 0.9 acres in two separate parcels. This leaves 1.2 acres of reforestation requirement which is to be fulfilled with a payment of a fee in-lieu.

PLANTING PLAN

The tree species selected are consistent with the mixed upland oak association native to the soil. Species will be randomly mixed and planted approximately 15' apart from other plantings. Straight rows should be avoided to simulate a more natural arrangement.

SPECIES	SIZE	QUANTITY
Tulip Poplar (<i>Liriodendron tulipifera</i>)	1" CAL	40
N. Red Oak (<i>Quercus rubra</i>)	1" CAL	40
Red Maple (<i>Acer rubrum</i>)	1" CAL	25
Black Cherry (<i>Prunus serotina</i>)	1" CAL	25
Scarlet Oak (<i>Quercus coccinea</i>)	1" CAL	15
Dogwood (<i>Cornus florida</i>)	1" CAL	30

OTHER PLANTING INSTRUCTIONS (See details on this sheet)
 Plant material should be obtained from a reputable nursery and ordered 3 to 6 months before desired delivery. Delivery should be arranged to occur as close to planting time as possible, and species should be protected from direct sun and drying until planting. Planting dates are October through May, with spring months preferred. (Suggested supplier: Sika Native Nursery & Seed Co., New Freedom, PA, (717) 237-0418)

MAINTENANCE AND PROTECTION OF PLANTED AREA
 Soil should be tested to determine the need for fertilizer. If fertilizer is needed, it should be applied at the testing lab's recommended rate after the first growing season (late fall or early spring). Organic or slow-release fertilizers are preferred.

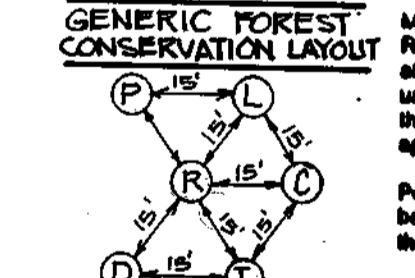

PLANTING MAINTENANCE
 Watering should be planned to compensate for deficient rainfall. New plantings need water once a week for the first growing season. The watering may only be necessary in July and August, and in subsequent years only water during drought periods. Watering should be done slowly enough to permit deep soaking of the root zone.

FOREST PROTECTION PLAN
 The forest conservation and reforestation area will need to be protected from injury during the land clearing and construction process, and from any future land use changes. Long-term protection will require planting the forest in a permanent, permanent, non-developable open space or conservation easement. The legal document establishing this protection will be required for final FCP approval.

TWO-YEAR POST-CONSTRUCTION MANAGEMENT PROGRAM
 Howard County requires the developer to commit to a minimum of two years of responsibility for the management of the Forest Conservation Area. The program must be supervised by a qualified professional. The obligations include: periodic (beginning and end of growing season) and ongoing maintenance of the forest, such as weeding, pruning, or invasive plant control; education of new land owners or occupants about appropriate activities and forest responsibilities; and a final inspection and certification that the forest is intact and the conditions of the FCP have been met submitted to the County. Upon review of the final certification, the County will notify the developer of release from all future obligations, and their treatment to the owner.

THE SANCTUARY FOREST CONSERVATION PLAN
FOREST CONSERVATION WORKSHEET

ITEM	ACRES
1. BASIC SITE DATA	
GRACE SITE AREA	7.2
AREA WITHIN 100 YEAR FLOODPLAIN	2.2
AREA WITHIN AGRICULTURAL USE OR PRESERVATION PARCEL	0.0
LAND USE CATEGORY (P-RLD, P-RMS, P-B, CHQ, 0, B-L)	2.2
NET TRACT AREA	7.2
REFORESTATION THRESHOLD (20% x A)	1.4
EXISTING FOREST ON NET TRACT AREA	1.4
FOREST AREA TO BE CLEARED	1.4
FOREST AREA TO BE RETAINED	1.4
NET TRACT AREA	7.2
REFORESTATION THRESHOLD (20% x A)	1.4
EXISTING FOREST ON NET TRACT AREA	1.4
FOREST AREA TO BE CLEARED	1.4
FOREST AREA TO BE RETAINED	1.4
FOREST AREAS CLEARED ABOVE REFORESTATION THRESHOLD (A-B)	0.0
FOREST AREAS CLEARED BELOW REFORESTATION THRESHOLD (A-B)	1.4
CLEARING BELOW THRESHOLD	0.0
REFORESTATION FOR CLEARING ABOVE THRESHOLD (B + 1/4)	2.0
REFORESTATION FOR CLEARING BELOW THRESHOLD (B + 1/2)	2.1
TOTAL REFORESTATION REQUIRED	2.1

PLANTING RESPONSIBILITIES

ITEM	BLUDDER	DEVELOPER	FINAL PLAN
STREET TREES		X	X
EDGES		X	X
SWM		X	X
PARKING		X	X
INTERNAL	X		

FEE IN LIEU 1.2 Ac x \$3560 (S.F.) x 0.3 = 15681.60
REFORESTATION 0.9 Ac x \$2560 (S.F.) x 0.3 = 11761.20
APPREHENSION 0.3 Ac x \$3560 (S.F.) x 0.05 = 1069.50
TOTAL \$28,512.30

FCP NOTES:
 1. Any Forest Conservation Easement (FCE) area shown hereon is subject to protective covenants which may be found in the Land Records of Howard County which restrict the disturbance and use of these areas.
 2. Forested areas occurring outside of the FCE shall not be considered part of the FCE and shall not be subject to protective land covenants.
 3. Limits of disturbance shall be restricted to areas outside the limits of temporary fencing or the FCE boundary, whichever is greater.
 4. There shall be no clearing, grading, construction or disturbance of vegetation in the Forest Conservation Easement, except as permitted by Howard County DPZ.

FINANCIAL SURETY - LANDSCAPE & FOREST CONSERVATION:
 1. DEVELOPER FINANCIAL SURETY FOR THE REQUIRED 52' LANDSCAPING WILL BE POSTED AS PART OF THE DEPARTMENT OF PUBLIC WORKS DEVELOPER'S AGREEMENT IN THE AMOUNT OF \$ 5,700.00
 2. THE DEVELOPER'S FINANCIAL SURETY FOR THE REQUIRED 185 FOREST CONSERVATION TREES MUST BE POSTED AS PART OF THE DEPARTMENT OF PUBLIC WORKS DEVELOPER'S AGREEMENT IN THE AMOUNT OF \$ 28,512.30

APPROVED: HOWARD COUNTY DEPARTMENT OF PLANNING AND ZONING
 [Signature] SA DATE 7/31/97
APPROVED: HOWARD COUNTY DEPARTMENT OF PUBLIC WORKS
 [Signature] DATE 7/19/97

PROJECT NAME: THE SANCTUARY
 P-97-07 A SUBDIVISION OF PARCELS 164,165,166,564,565 & 566
 S-94-25 FIRST ELECTION DISTRICT TAX MAP #37
 HOWARD COUNTY, MARYLAND

TITLE: LANDSCAPING & FOREST CONSERVATION PLAN

DEVELOPER: BURNATTY INVESTMENTS LTD. P.O. BOX 999 COLUMBIA, MARYLAND 21044
OWNER: MR. ROBERT O'LEXY 6693 OLD WATERLOO ROAD BALTIMORE, MARYLAND 20794
OWNER: BURNATTY INVESTMENTS LTD. P.O. BOX 999 COLUMBIA, MARYLAND 21044
OWNER: MR. GLORIA M. DETRICH 6719 OLD WATERLOO ROAD BALTIMORE, MARYLAND 20794

DES.: D.C.W. **JOB:**
DRW.: AVG **PROJ.:** SNLDCSP.DWG **SCALE:** 1" = 50'
CHK.: D.C.W. **DATE:** 6-18-97 **SHEET:** 7 OF 7