

WETLAND LINE TABLE

LINE	DIRECTION	DISTANCE
W1	N64°49'02"E	26.62'
W2	N35°00'52"E	17.29'
W3	N14°56'36"W	21.98'
W4	S41°39'26"W	17.06'
W5	S57°06'59"W	28.69'

FLOODPLAIN LINE TABLE

LINE	DIRECTION	DISTANCE
FP1	S84°41'15"W	28.00'
FP2	S04°05'24"W	8.14'
FP3	S16°54'57"E	12.48'
FP4	S25°55'19"W	18.34'
FP5	S39°16'13"E	19.18'
FP6	N90°00'00"W	6.01'
FP7	S33°31'27"E	8.16'
FP8	S28°46'01"E	7.08'
FP9	N66°37'22"E	27.45'
FP10	N73°30'06"E	7.36'
FP11	S74°50'58"W	3.57'
FP12	S81°52'30"W	2.71'
FP13	N90°00'00"E	1.54'
FP14	N73°19'10"W	2.00'
FP15	N30°28'06"W	3.52'
FP16	N36°00'11"W	14.69'
FP17	N34°06'50"W	9.58'
FP18	N20°42'02"E	8.01'
FP19	N19°30'44"E	5.78'
FP20	N17°59'53"E	3.85'
FP21	S63°33'27"W	2.13'
FP22	S27°17'40"W	7.67'
FP23	S19°48'44"W	15.23'
FP24	S06°10'52"W	8.80'
FP25	S07°58'38"W	20.42'
FP26	S20°15'55"W	21.53'
FP27	S27°17'40"W	24.04'
FP28	N68°33'27"E	31.42'

COORDINATE TABLE

NO.	NORTHING	EASTING
1	600,155.3831	1,345,339.3536
2	600,152.7214	1,344,722.9318
3	600,894.9268	1,344,645.3413
4	600,897.1729	1,344,666.8267
5	600,862.3625	1,344,670.4658
6	600,866.5215	1,344,710.2490
7	600,926.5133	1,344,703.9774
8	600,939.7307	1,344,825.6587
9	600,913.5186	1,344,829.8520
10	600,650.1304	1,344,977.0900
11	600,439.6380	1,344,983.9136
12	600,440.4114	1,345,163.0428
13	600,236.6354	1,345,336.7221
14	600,808.4520	1,344,716.3196
15	600,772.6666	1,344,710.6313
16	600,757.3300	1,344,708.1935
17	600,702.5015	1,344,713.9253
18	600,606.3271	1,344,736.9154
19	600,563.1704	1,344,753.4127
20	600,527.1290	1,344,757.1499
21	600,511.6826	1,344,758.7516
22	600,354.6928	1,344,818.7631
23	600,359.9579	1,344,828.0919
24	600,340.6246	1,344,839.0035
25	600,310.0524	1,344,784.8354
26	600,329.3857	1,344,773.9238
27	600,334.8128	1,344,783.5396
28	600,497.4001	1,344,721.3884
29	600,533.4415	1,344,717.6502
30	600,548.8878	1,344,716.0495
31	600,592.0445	1,344,699.5522
32	600,698.3426	1,344,674.1421
33	600,753.1711	1,344,668.4103
34	600,788.9564	1,344,674.0986
35	600,804.2930	1,344,676.5364

NOTE: COORDINATES AND GRID TICS SHOWN HEREON ARE BASED ON NAD '83 AND ARE IN FEET, TO CONVERT TO METERS DIVIDE BY 3.28083333.

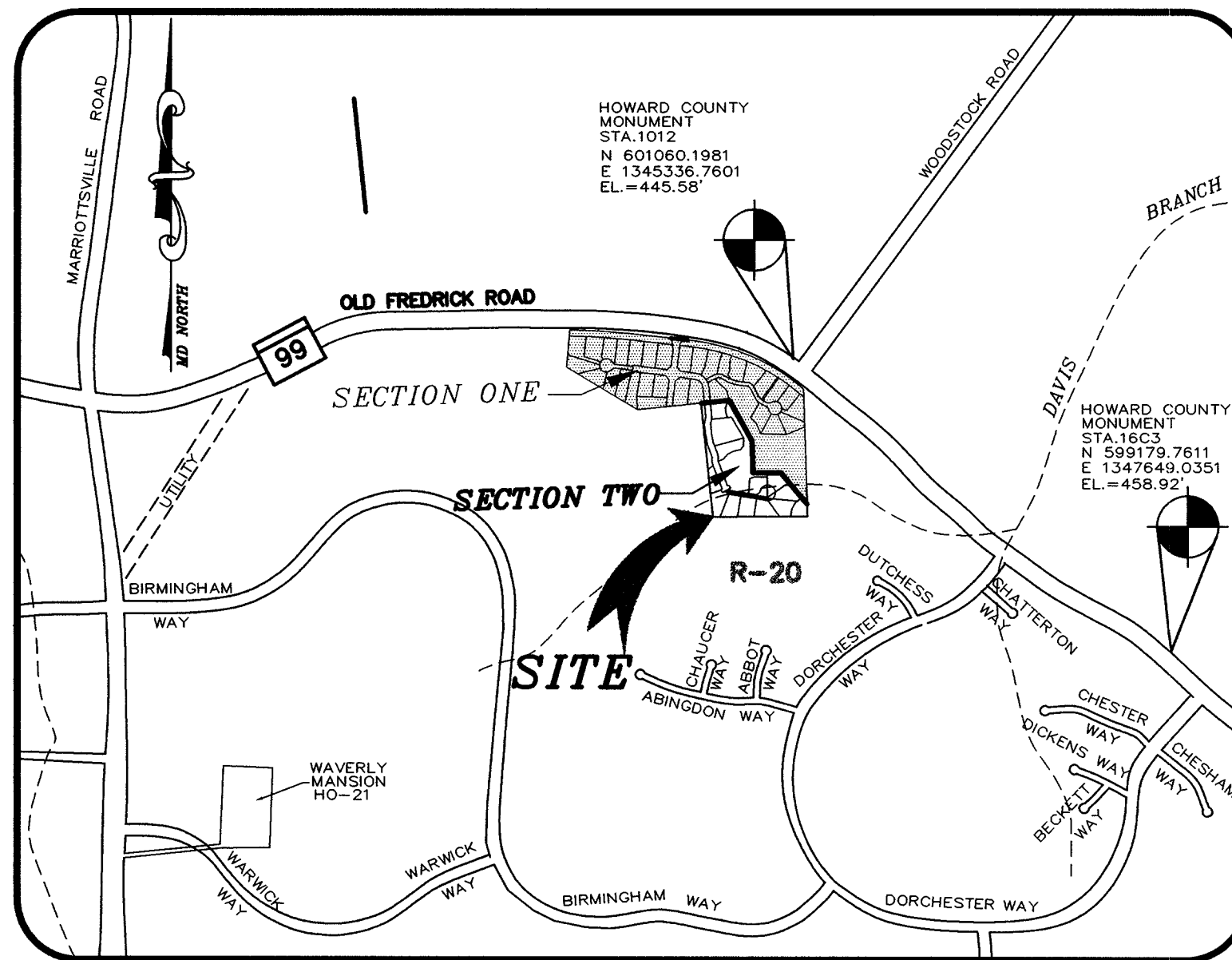

VICINITY MAP

SCALE: 1=1000'

CURVE DATA

CURVE	RADIUS	LENGTH	TANGENT	CHORD	BEARING	DELTA
C1	70.00	36.65	18.76	36.23	S09°01'55"W	30°00'00"
C2	30.00	15.71	8.04	15.53	S09°01'55"W	30°00'00"
C3	380.00	99.17	49.87	98.88	S13°26'39"E	14°57'07"
C4	70.00	36.65	18.76	36.23	S05°55'12"E	30°00'00"
C5	30.00	15.71	8.04	15.53	S05°55'12"E	30°00'00"
C6	38.00	23.09	11.91	22.73	S63°30'55"E	34°48'34"
C7	35.00	51.27	31.47	46.80	N57°07'08"E	83°55'19"
C8	50.00	230.32	55.61	74.36	S32°52'52"E	263°55'19"
C9	62.00	12.75	6.40	12.73	N75°01'34"W	11°47'12"
C10	62.00	31.99	16.36	31.64	N54°20'59"W	29°33'58"
C11	70.00	36.65	18.76	36.23	N05°55'12"W	30°00'00"
C12	30.00	15.71	8.04	15.53	N05°55'12"W	30°00'00"
C13	420.00	109.60	55.12	109.29	N13°26'39"W	14°57'07"
C14	70.00	36.65	18.76	36.23	N09°01'55"E	30°00'00"
C15	30.00	15.71	8.04	15.53	N09°01'55"E	30°00'00"
C16	41.43	26.19	13.55	25.76	S62°48'28"E	36°13'28"
C17	44.86	29.29	15.19	28.78	S62°12'44"E	37°24'56"
C18	48.29	32.39	16.83	31.78	S61°42'14"E	38°25'57"
C19	51.71	35.48	18.47	34.79	S61°15'52"E	39°18'41"
C20	55.14	38.57	20.11	37.79	S60°52'51"E	40°04'42"
C21	58.57	41.66	21.76	40.79	S60°32'35"E	40°45'14"

OPEN SPACE REQUIREMENTS
(BASED ON MINIMUM LOT SIZE OF 14,000 SQUARE FEET)

	TAYLOR FARM SECTION ONE (F-98-141)	TAYLOR FARM SECTION TWO (F-99-125)	TOTALS
GROSS AREA	16.81 AC±	6.66 AC±	23.47 AC±
OPEN SPACE REQ'D	5.06 AC±	2.00 AC±	7.06 AC±
CREDITED OPEN SPACE PROVIDED	5.21 AC±	1.97 AC±	7.18 AC±
RECREATION AREA REQ'D	6,000 SF	2,200 SF	8,200 SF
RECREATION AREA PROVIDED	10,500 SF	-	10,500 SF

MINIMUM LOT SIZE CHART

LOT #	GROSS AREA (SF)	PIPESTEM AREA(SF)	MINIMUM LOT SIZE(SF)
41	14,478	478	14,000
42	14,922	914	14,008
43	15,085	903	14,182
44	14,928	928	14,000
45	14,715	715	14,000
46	14,367	367	14,000
47	14,106	106	14,000

- 33. PRIVATE ACCESS PLACE IS FOR USE BY LOTS 41 - 48 ONLY. THOSE LOTS WILL HAVE ADDRESSES ASSIGNED ON "RED DAHLIA DRIVE".
- 34. INGRESS, EGRESS AND MAINTENANCE OF THE PRIVATE ACCESS PLACE IS PURSUANT TO THE DECLARATION OF RIGHT OF ACCESS AND MAINTENANCE OBLIGATIONS RECORDED AMONG THE LAND RECORDS OF HOWARD COUNTY, MARYLAND.
- 35. THE 4'x10' CONCRETE REFUSE & RECYCLE PAD (6 INCHES IN DEPTH) LOCATED IN OPEN SPACE LOT 50, WILL BE MAINTAINED BY THE OWNERS OF LOTS 41 - 48 PURSUANT TO THE DECLARATION OF RIGHT OF ACCESS AND MAINTENANCE OBLIGATIONS RECORDED AMONG THE LAND RECORDS OF HOWARD COUNTY, MARYLAND.
- 36. Declaration of HOA Covenants recorded in the Land Records of Howard County, Maryland, at Liber 5048, Folio 245, titled "Taylor Farm at Waverly Woods. An Amendment to the Covenants was recorded at Liber 5125, Folio 55."

THIS SUBDIVISION IS SUBJECT TO SECTION 18.122B OF THE HOWARD COUNTY CODE. PUBLIC WATER AND PUBLIC SEWER SERVICE HAS BEEN GRANTED UNDER THE TERMS AND PROVISIONS. THEREOF EFFECTIVE JUNE 8, 2000 ON WHICH DATE DEVELOPER AGREEMENT 24-3743-D WAS FILED AND ACCEPTED.

THE REQUIREMENTS OF §§3-108, THE REAL PROPERTY ARTICLE, ANNOTATED CODE OF MARYLAND, 1988 REPLACEMENT VOLUME (AS SUPPLEMENTED) AS FAR AS THEY RELATE TO THE MAKING OF THIS PLAT AND THE SETTING OF MARKERS HAVE BEEN COMPLIED WITH.

John B. Mildenberg 6/21/00
JOHN B. MILDENBERG, SURVEYOR
DATE

Edward W. Offutt 6/21/00
EDWARD W. OFFUTT, SECRETARY
TAYLOR FARM DEVELOPMENT CORP.
DATE

Richard W. Doyle, Sr. 6/21/00
RICHARD W. DOYLE, SR., PRESIDENT
TAYLOR FARM DEVELOPMENT CORP.
DATE

TOTAL AREA TABULATION

TOTAL NUMBER OF BUILDABLE LOTS TO BE RECORDED	11
TOTAL NUMBER OF BULK PARCELS	1
TOTAL NUMBER OF OPEN SPACE LOTS TO BE RECORDED	3
TOTAL NUMBER OF LOTS OR PARCELS TO BE RECORDED	15
TOTAL AREA OF BUILDABLE LOTS TO BE RECORDED	3.969 AC±
TOTAL AREA OF BULK PARCELS	0.192 AC±
TOTAL AREA OF OPEN SPACE LOTS TO BE RECORDED	1.970 AC±
TOTAL AREA OF 100 YR FLOOD PLAIN TO BE RECORDED	0.712 AC±
TOTAL AREA OF LOTS OR PARCELS TO BE RECORDED	6.131 AC ±
TOTAL AREA OF ROADWAY TO BE RECORDED	0.527 AC ±
TOTAL AREA TO BE RECORDED	6.658 AC ±

APPROVED: FOR PUBLIC WATER AND PUBLIC SEWERAGE SYSTEMS
HOWARD COUNTY HEALTH DEPARTMENT

Diane L. Mattingly 6-29-00
HOWARD COUNTY HEALTH OFFICER
DATE

APPROVED: HOWARD COUNTY DEPARTMENT OF PLANNING AND ZONING

Edward W. Offutt 6/27/00
CHIEF, DEVELOPMENT ENGINEERING DIVISION
DATE

John B. Mildenberg 7/3/00
DIRECTOR
DATE

OWNER'S STATEMENT

I, TAYLOR FARM DEVELOPMENT CORP., OWNER OF THE PROPERTY SHOWN AND DESCRIBED HEREON, HEREBY ADOPT THIS PLAN OF SUBDIVISION, AND IN CONSIDERATION OF THE APPROVAL OF THIS FINAL PLAT BY THE DEPARTMENT OF PLANNING AND ZONING, ESTABLISH THE MINIMUM BUILDING RESTRICTION LINES AND GRANT UNTO HOWARD COUNTY, MARYLAND, ITS SUCCESSORS AND ASSIGNS, 1) THE RIGHT TO LAY, CONSTRUCT AND MAINTAIN SEWERS, DRAINS, WATER PIPES AND OTHER MUNICIPAL UTILITIES AND SERVICES, IN AND UNDER ALL ROADS AND STREET RIGHT-OF-WAYS AND THE SPECIFIC EASEMENTS SHOWN HEREON, 2) THE RIGHT TO REQUIRE DEDICATION FOR PUBLIC USE, THE BEDS OF THE STREETS AND/OR ROADS AND FLOODPLAINS AND OPEN SPACE WHERE APPLICABLE, AND FOR GOOD AND OTHER VALUABLE CONSIDERATION, HEREBY GRANT THE RIGHT AND OPTION TO HOWARD COUNTY TO ACQUIRE THE FEE SIMPLE TITLE TO THE BEDS OF THE STREETS AND/OR ROADS AND FLOODPLAINS, STORM DRAINAGE FACILITIES AND OPEN SPACE WHERE APPLICABLE, 3) THE RIGHT TO REQUIRE DEDICATION OF WATERWAY AND DRAINAGE EASEMENTS FOR THE SPECIFIC PURPOSE OF THEIR CONSTRUCTION, REPAIR AND MAINTENANCE, AND 4) THAT NO BUILDING OR SIMILAR STRUCTURE OF ANY KIND SHALL BE ERRECTED ON OR OVER THE SAID EASEMENT AND RIGHTS-OF-WAY.

WITNESS MY HAND THIS 21 DAY OF 2000, JUNE

Edward W. Offutt
EDWARD W. OFFUTT, SECRETARY
TAYLOR FARM DEVELOPMENT CORP.
WITNESS

Richard W. Doyle, Sr.
RICHARD W. DOYLE, SR., PRESIDENT
TAYLOR FARM DEVELOPMENT CORP.
WITNESS

SURVEYOR'S CERTIFICATE

I HEREBY CERTIFY THAT THE FINAL PLAT SHOWN HEREON IS CORRECT; THAT IT IS A SUBDIVISION OF THE LAND CONVEYED BY EDWARD W. OFFUTT & RICHARD W. DOYLE, SR. TO TAYLOR FARM DEVELOPMENT CORP. BY DEED DATED SEPTEMBER 28, 1998 AND RECORDED AMONG THE LAND RECORDS OF HOWARD COUNTY, MARYLAND IN LIBER NO. 4448 AT FOLIO 535 AND THAT ALL MONUMENTS IN PLACE OR WILL BE IN PLACE PRIOR TO THE ACCEPTANCE OF THE STREETS IN THE SUBDIVISION BY HOWARD COUNTY AS SHOWN IN ACCORDANCE WITH THE ANNOTATED CODE OF MARYLAND AS AMENDED, AND THE BOUNDARY SURVEY IS IN ACCORDANCE WITH THE COUNTY SUBDIVISION REGULATIONS.

John B. Mildenberg 6/21/00
JOHN B. MILDENBERG, L.S. NO. 12718
DATE

GENERAL NOTES:

- SUBJECT PROPERTY ZONED R-20 PER THE 10/18/93 COMPREHENSIVE ZONING PLAN.
- HORIZONTAL AND VERTICAL DATUMS BASED ON MARYLAND STATE COORDINATE SYSTEM (NAD 83)
STA 16C3 N 599179.7611 E 1347649.0351 EL.=458.92
STA 1012 N 601060.1981 E 1345336.7601 EL.=445.58
- THIS PLAT IS BASED ON A FIELD RUN MONUMENTED BOUNDARY SURVEY PERFORMED ON JULY 1997 BY MILDENBERG, BOENDER AND ASSOCIATES, INC.
- BRL DENOTES BUILDING RESTRICTION LINE.
- DENOTES STONE FOUND
- DENOTES IRON PIPE FOUND.
- DENOTES CONCRETE MONUMENT FOUND.
- DENOTES ANGULAR CHANGE IN DIRECTION OF BOUNDARY.
- STEEP SLOPES EXIST ON-SITE.
- NO BURIAL OR CEMETERY SITES EXIST ON-SITE.
- ALL AREAS SHOWN ARE MORE OR LESS (±).
- SURVEY WORK AND DOCUMENTS HAVE BEEN PERFORMED IN CONFORMANCE WITH SUBTITLE 13, BOARD OF PROFESSIONAL LAND SURVEYORS, 09.13.06 STATE OF MARYLAND, MINIMUM STANDARDS OF PROFESSIONAL PRACTICE.
- THIS SUBDIVISION IS IN THE METROPOLITAN DISTRICT.
- Denotes PUBLIC 100 YEAR FLOODPLAIN, DRAINAGE, & UTILITY EASEMENT.
 - Denotes PUBLIC & PRIVATE DRAINAGE & UTILITY EASEMENT.
 - Denotes WETLANDS.
 - Denotes 24' PRIVATE ROAD AND UTILITY EASEMENT.
 - Denotes 10' PUBLIC TREE MAINTENANCE AND UTILITY EASEMENT.
 - Denotes FOREST CONSERVATION EASEMENT (RETENTION & REFORESTATION).
 - Denotes PUBLIC WATER & SEWER EASEMENT.
- NO CLEARING, GRADING OR CONSTRUCTION IS PERMITTED WITHIN WETLANDS AND STREAM BUFFERS OR FOREST CONSERVATION AREAS. EXCEPT AS SHOWN ON APPROVED PLANS.
- RECREATIONAL OPEN SPACE REQUIRED = 200 SQ.FT./LOT x 11 = 2,200 SQ.FT. RECREATIONAL OPEN SPACE IS PROVIDED UNDER F-98-141.
- AREA OF SUBDIVISION = 6.658 Ac. ±
MINIMUM BUILDABLE LOT AREA = 14,000 SQ. FT.
OPEN SPACE REQUIRED = R-20 @ 30% = 1.997 Ac. ±
OPEN SPACE PROVIDED = 1.971 Ac. ±
(SEE OPEN SPACE REQUIREMENTS)
- THERE ARE NO HISTORIC DISTRICTS ADJACENT TO THE SITE.
- FOR FLAG OR PIPESTEM LOTS 41 - 48, REFUSE COLLECTION, SNOW REMOVAL AND ROAD MAINTENANCE ARE PROVIDED TO THE JUNCTION OF THE FLAG OR PIPESTEM AND THE ROAD RIGHT-OF-WAY LINE FOR RED DAHLIA DRIVE, AND NOT ONTO THE FLAG OR THE PIPESTEM DRIVEWAY.
- ALL EXISTING STRUCTURES TO BE REMOVED.
- FLOODPLAIN LIMITS BASED ON STUDY BY MILDENBERG, BOENDER AND ASSOC. INC. DATED: JUNE 1997.
- STORMWATER MANAGEMENT FOR THIS DEVELOPMENT IS PROVIDED BY THE METHOD OF RETENTION UNDER F-95-174. (GTW'S WAVERLY)
- FOREST CONSERVATION REQUIREMENTS HAVE BEEN SATISFIED UNDER F-98-141. REFORESTATION AND RETENTION ON TAYLOR FARM SECTIONS ONE & TAYLOR FARM SECTION TWO AND OFF-SITE RETENTION OF 2.6 ACRES (CREDITED FOR 1.3 ACRES OF ON-SITE OBLIGATIONS) OF FOREST ON THE BIRDS EYE VIEW FARM, FOREST CONSERVATION PLAT OF EASEMENT (PLAT #13599).
- LIMITS OF WETLANDS ARE BASED ON STUDY BY WILDMAN ENVIRONMENTAL SERVICES IN APRIL 1998.
- DEVELOPER RESERVES UNTO ITSELF, ITS SUCCESSORS AND ASSIGNS, ALL EASEMENTS SHOWN ON THIS PLAT FOR WATER, SEWER, STORM DRAINAGE, FOREST CONSERVATION, AND OTHER PUBLIC UTILITIES LOCATED IN, OVER AND THROUGH LOTS 38 THRU 48, OPEN SPACE LOTS 49 THRU 51 AND BULK PARCEL B ALL OR PORTIONS THEREOF. FOR ANY AND ALL CONVEYANCES OF AFORESAID LOTS SHALL BE SUBJECT TO THE EASEMENTS HEREIN RESERVED, WHETHER OR NOT EXPRESSLY STATED IN THE DEED(S) CONVEYING SAID LOT(S). DEVELOPER SHALL EXECUTE AND DELIVER DEEDS FOR THE EASEMENTS HEREIN DEDICATED TO HOWARD COUNTY, UPON COMPLETION OF THE PUBLIC UTILITIES AND THEIR ACCEPTANCE BY HOWARD COUNTY, THE COUNTY SHALL ACCEPT THE EASEMENTS AND RECORD THE DEED(S) OF THE EASEMENT IN THE LAND RECORDS OF HOWARD COUNTY.
- MDE NON-TIDAL WETLANDS AUTHORIZATION LETTER 99-NI-0010; TRACKING # 199960523.

OWNER
TAYLOR FARM DEVELOPMENT CORP.
2705 FALSTON ROAD
FALSTON, MD 21047

THE PURPOSE OF THIS PLAT IS TO RESUBDIVIDE BULK PARCEL "A" OF TAYLOR FARM SECTION ONE LOTS 1 THRU 33 AND BULK PARCEL "A" INTO TAYLOR FARM SECTION TWO, LOTS 38 THRU 51 & BULK PARCEL "B", TO RECONFIGURE FOREST CONSERVATION EASEMENT D, TO ABANDON FOREST CONSERVATION EASEMENT E, AND TO ADD A NEW FOREST CONSERVATION EASEMENT E.

RECORDED AS PLAT 14317 ON 7/5/00 AMONG THE LAND RECORDS OF HOWARD COUNTY, MD.

TAYLOR FARM
SECTION TWO
LOTS 38 THRU 51 & BULK PARCEL "B"
A RESUBDIVISION OF BULK PARCEL "A" OF TAYLOR FARM SECTION ONE, LOTS 1 THRU 33 AND BULK PARCEL "A"
SHEET 1 OF 2

TAX MAP 10 THIRD ELECTION DISTRICT SCALE: AS SHOWN
PARCEL NO. 309 HOWARD COUNTY, MARYLAND DATE: JUNE 22, 2000
BLOCK 23 EX. ZONING R-20
LOT 4 DPZ FILE NOS.: S-95-21; F-96-14; F-89-235; P-98-02; WP-89-19
BULK PARCEL "A" F-98-141; SP-98-16; SDP-99-138; F-99-159

MILDENBERG, BOENDER & ASSOC., INC.
Engineers Planners Surveyors
5072 Dorsey Hall Drive, Suite 202, Ellicott City, Maryland 21042
(410) 997-0296 Balt. (301) 621-5521 Wash. (410) 997-0298 Fax.

KENNARD WARFIELD
PARCEL 21, 109/117
ZONE-R20

100 YEAR FLOODPLAIN
(F-95-174)

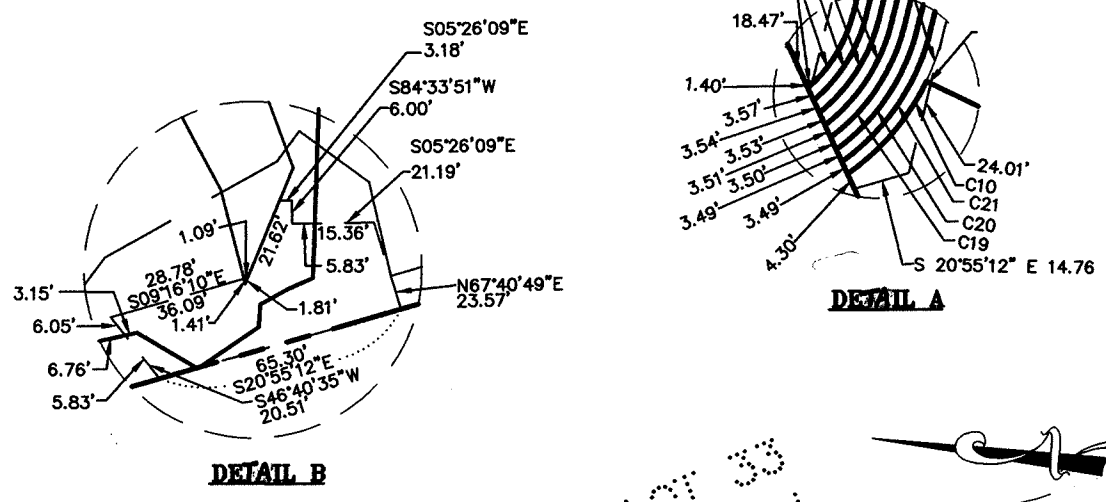
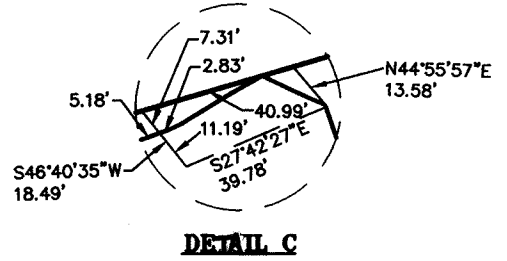
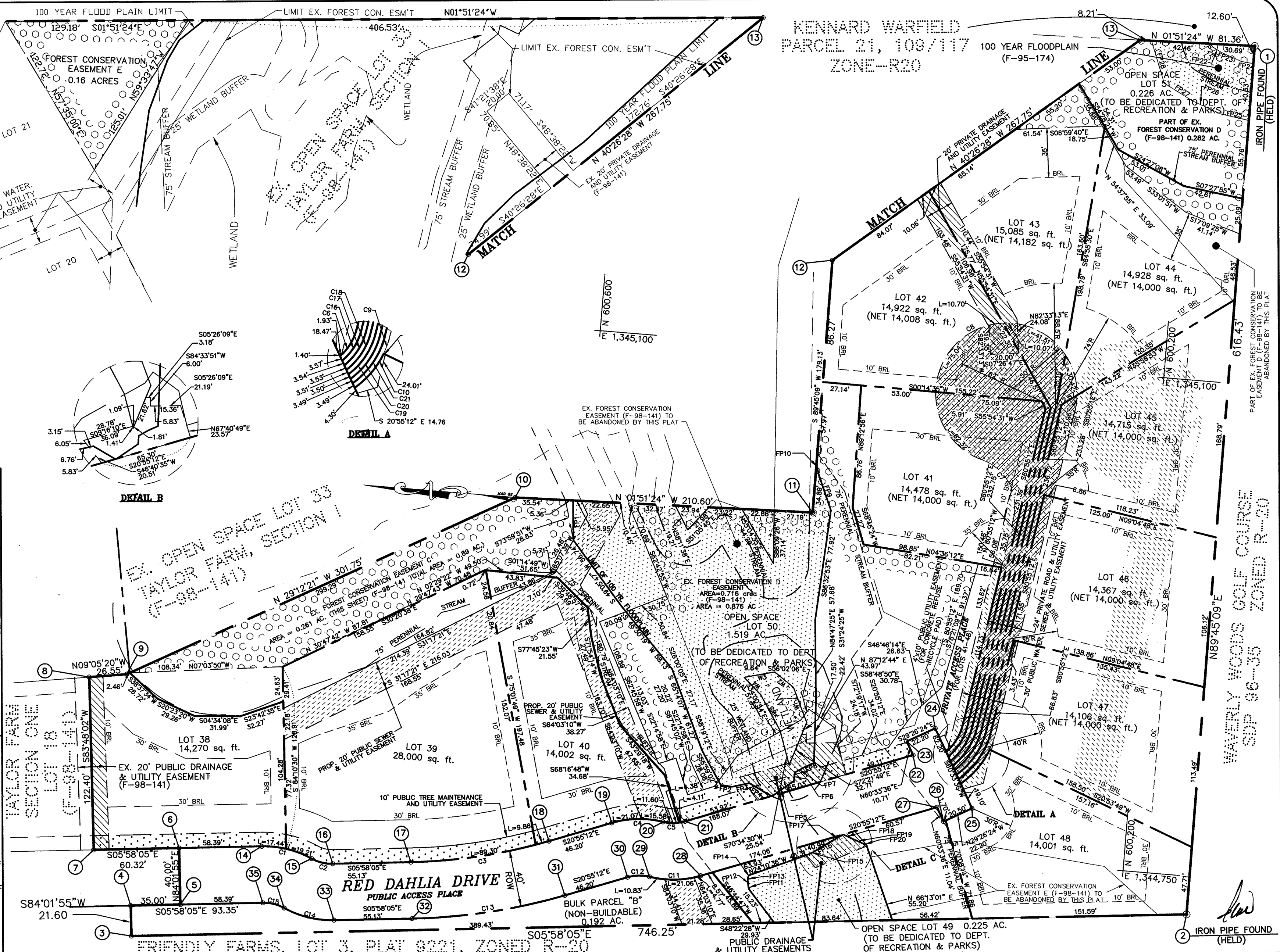

OWNER
TAYLOR FARM DEVELOPMENT CORP.
2705 FALSTON ROAD
FALSTON, MD 21047

THIS SUBDIVISION IS SUBJECT TO SECTION 18.122B OF THE HOWARD COUNTY CODE. PUBLIC WATER AND PUBLIC SEWER SERVICE HAS BEEN GRANTED UNDER THE TERMS AND PROVISIONS THEREOF EFFECTIVE JUNE 8, 2000 ON WHICH DATE DEVELOPER AGREEMENT 24-3743-D WAS FILED AND ACCEPTED.

THE REQUIREMENTS OF 3-108, THE REAL PROPERTY ARTICLE, ANNOTATED CODE OF MARYLAND, 1988 REPLACEMENT VOLUME (AS SUPPLEMENTED) AS FAR AS THEY RELATE TO THE MAKING OF THIS PLAT AND THE SETTING OF MARKERS HAVE BEEN COMPLETED WITH.

John B. Miltenberg 6/29/00
JOHN B. MILTENBERG, SURVEYOR DATE
Edward W. Offutt 6/21/00
EDWARD W. OFFUTT, SECRETARY DATE
TAYLOR FARM DEVELOPMENT CORP.
Richard W. Doyle, Sr. 6/21/00
RICHARD W. DOYLE, SR., PRESIDENT DATE
TAYLOR FARM DEVELOPMENT CORP.

TOTAL AREA TABULATION

TOTAL NUMBER OF BUILDABLE LOTS TO BE RECORDED	11
TOTAL NUMBER OF BULK PARCELS	1
TOTAL NUMBER OF OPEN SPACE LOTS TO BE RECORDED	3
TOTAL NUMBER OF LOTS OR PARCELS TO BE RECORDED	15
TOTAL AREA OF BUILDABLE LOTS TO BE RECORDED	3.969 AC±
TOTAL AREA OF BULK PARCELS TO BE RECORDED	0.192 AC±
TOTAL AREA OF OPEN SPACE LOTS TO BE RECORDED	1.970 AC±
TOTAL AREA OF 100 YR FLOOD PLAIN TO BE RECORDED	0.712 AC±
TOTAL AREA OF FOREST CONSERVATION EASEMENT TO BE RECORDED	0.442 AC±
TOTAL AREA OF LOTS OR PARCELS TO BE RECORDED	6.131 AC ±
TOTAL AREA OF ROADWAY TO BE RECORDED	0.527 AC ±
TOTAL AREA TO BE RECORDED	6.658 AC ±

APPROVED: FOR PUBLIC WATER AND PUBLIC SEWERAGE SYSTEMS
HOWARD COUNTY HEALTH DEPARTMENT

Diane L. McDonald 6-29-00
DIANE L. McDONALD, HOWARD COUNTY HEALTH OFFICER DATE

APPROVED: HOWARD COUNTY DEPARTMENT OF PLANNING AND ZONING

David Williamson 6/27/00
DAVID WILLIAMSON, CHIEF, DEVELOPMENT ENGINEERING DIVISION DATE
Joseph J. Smith 7/3/00
JOSEPH J. SMITH, DIRECTOR DATE

OWNER'S STATEMENT

I, TAYLOR FARM DEVELOPMENT CORP., OWNER OF THE PROPERTY SHOWN AND DESCRIBED HEREON, HEREBY ADOPT THIS PLAN OF SUBDIVISION, AND IN CONSIDERATION OF THE APPROVAL OF THIS FINAL PLAT BY THE DEPARTMENT OF PLANNING AND ZONING, ESTABLISH THE MINIMUM BUILDING RESTRICTION LINES AND GRANT UNTO HOWARD COUNTY, MARYLAND, ITS SUCCESSORS AND ASSIGNS: 1) THE RIGHT TO LAY, CONSTRUCT AND MAINTAIN SEWERS, DRAINS, WATER PIPES AND OTHER MUNICIPAL UTILITIES AND SERVICES IN AND UNDER ALL ROADS AND STREET RIGHT-OF-WAYS AND THE SPECIFIC EASEMENTS SHOWN HEREON; 2) THE RIGHT TO REQUIRE DEDICATION FOR PUBLIC USE, THE BEDS OF THE STREETS AND/OR ROADS AND FLOODPLAINS AND OPEN SPACE WHERE APPLICABLE, AND FOR GOOD AND OTHER VALUABLE CONSIDERATION, HEREBY GRANT THE RIGHT AND OPTION TO HOWARD COUNTY TO ACQUIRE THE FEE SIMPLE TITLE TO THE BEDS OF THE STREETS AND/OR ROADS AND FLOODPLAINS, STORM DRAINAGE FACILITIES AND OPEN SPACE WHERE APPLICABLE; 3) THE RIGHT TO REQUIRE DEDICATION OF WATERWAY AND DRAINAGE EASEMENTS FOR THE SPECIFIC PURPOSE OF THEIR CONSTRUCTION, REPAIR AND MAINTENANCE; AND 4) THAT NO BUILDING OR SIMILAR STRUCTURE OF ANY KIND SHALL BE ERRECTED ON OR OVER THE SAID EASEMENT AND RIGHTS-OF-WAY.

WITNESS MY HAND THIS 21 DAY OF 2000, JUNE

Edward W. Offutt
EDWARD W. OFFUTT, SECRETARY
TAYLOR FARM DEVELOPMENT CORP.
Richard W. Doyle, Sr.
RICHARD W. DOYLE, SR., PRESIDENT
TAYLOR FARM DEVELOPMENT CORP.

John B. Miltenberg
JOHN B. MILTENBERG, SURVEYOR
Edward W. Offutt
EDWARD W. OFFUTT, SECRETARY
Richard W. Doyle, Sr.
RICHARD W. DOYLE, SR., PRESIDENT

SURVEYOR'S CERTIFICATE

I HEREBY CERTIFY THAT THE FINAL PLAT SHOWN HEREON IS CORRECT; THAT IT IS A SUBDIVISION OF THE LAND CONVEYED BY EDWARD W. OFFUTT & RICHARD W. DOYLE, SR. TO TAYLOR FARM DEVELOPMENT CORP. BY DEED DATED SEPTEMBER 28, 1998 AND RECORDED AMONG THE LAND RECORDS OF HOWARD COUNTY, MARYLAND IN LIBER No. 4448 AT FOLIO 535 AND THAT ALL MONUMENTS IN PLACE OR WILL BE IN PLACE PRIOR TO THE ACCEPTANCE OF THE STREETS IN THE SUBDIVISION BY HOWARD COUNTY AS SHOWN IN ACCORDANCE WITH THE ANNOTATED CODE OF MARYLAND AS AMENDED, AND THE BOUNDARY SURVEY IS IN ACCORDANCE WITH THE HOWARD COUNTY SUBDIVISION REGULATIONS.

John B. Miltenberg
JOHN B. MILTENBERG, SURVEYOR
DATE: 6/29/00

RECORDED AS PLAT 14318 ON 7/5/00 AMONG THE LAND RECORDS OF HOWARD COUNTY, MD.

TAYLOR FARM SECTION TWO
LOTS 38 THRU 51 & BULK PARCEL "B"
A RESUBDIVISION OF BULK PARCEL "A" OF TAYLOR FARM SECTION ONE, LOTS 1 THRU 33 AND BULK PARCEL "A"

TAX MAP 10 THIRD ELECTION DISTRICT SCALE: 1" = 50'
PARCEL NO. 309 HOWARD COUNTY, MARYLAND DATE: JUNE 22, 2000
BLOCK 23 EX. ZONING R-20
LOT 4 DPZ FILE NOS.: S-95-21; F-86-14; F-89-235; P-98-02
BULK PARCEL "A" WP-98-19; F-98-141; SDP-99-138; F-99-159

MILDENBERG, BOENDER & ASSOC., INC.
Engineers Planners Surveyors
5072 Dorsey Hall Drive, Suite 202, Ellicott City, Maryland 21042
(410) 997-0296 Balt. (301) 621-5521 Wash. (410) 997-0298 Fax.

F:\96085.DWG\SEC2\FINAL\RP_085-RP2.DWG