

INDEX OF SHEETS

SHEET NO.	DESCRIPTION
1	TITLE SHEET (TI-1)
2-3	TYPICAL SECTIONS (TS-1 - TS-2)
4	TYPICAL SECTIONS AND ROADWAY DETAILS (TS-3)
5-7	PLAN SHEETS (PS-1 - PS-3)
8-10	STORM DRAIN PROFILES (PP-1 - PP-3)
11	DRAINAGE DETAILS (DD-1)
12-13	EROSION AND SEDIMENT CONTROL NOTES AND DETAILS (ED-1 - ED-2)
14-16	EROSION AND SEDIMENT CONTROL PLANS (EP-1 - EP-3)
17	MAINTENANCE OF TRAFFIC AND DETOUR PLAN (TP-1)

GENERAL NOTES

- ALL INFORMATION AND DETAILS ON THESE DRAWINGS SHALL BE CONSTRUCTED AS PER THE PLANS OR AS DIRECTED BY THE HOWARD COUNTY ENGINEER.
- ALL STATIONING AND DIMENSIONING ARE TO BE FIELD VERIFIED BY THE CONTRACTOR
- STORM DRAINAGE SLOPES ARE TO BE AS SHOWN ON THE PLANS OR AS DIRECTED BY THE HOWARD COUNTY ENGINEER
- APPROXIMATE LOCATIONS OF EXISTING UTILITIES ARE SHOWN. THESE LOCATIONS ARE FOR INFORMATIONAL PURPOSES ONLY AND ARE NOT GUARANTEED TO BE ACCURATE OR ALL INCLUSIVE. THE CONTRACTOR SHALL TAKE ALL NECESSARY PRECAUTIONS TO PROTECT EXISTING UTILITIES AND TO MAINTAIN UNINTERRUPTED SERVICE. ANY DAMAGE INCURRED SHALL BE REPAIRED IMMEDIATELY TO THE SATISFACTION OF THE ENGINEER BY THE CONTRACTOR AT THE CONTRACTOR'S EXPENSE. THE CONTRACTOR SHALL NOTIFY THE FOLLOWING UTILITIES OR AGENCIES AT LEAST FIVE (5) DAYS BEFORE STARTING WORK SHOWN ON THESE PLANS.

AT&T .....	1-800-252-1133
COMCAST .....	410-461-1362
BC&E (CONTRACTOR SERVICES) .....	410-850-4620
BC&E (UNDERGROUND DRAINAGE CONTROL) .....	410-787-9068
MISS UTILITY .....	1-800-257-7777
HOWARD COUNTY BUREAU OF UTILITIES .....	410-313-4900
HOWARD COUNTY DIVISION OF CONSTRUCTION INSPECTION .....	410-313-1880
VERIZON .....	1-800-743-0033/410-224-9210

THE CONTRACTOR SHALL CONTACT THE HOWARD COUNTY CONSTRUCTION INSPECTION DIVISION OF ENGINEERING FOR VERIFICATION AND/OR INFORMATION REGARDING:

- PROPOSED/EXISTING RIGHT-OF-WAY.
- UTILITY RELOCATION.
- MAINTENANCE OF TRAFFIC DURING CONSTRUCTION.
- EROSION/SEDIMENT CONTROL CERTIFICATION AND PERMIT.
- HORIZONTAL/VERTICAL SURVEY CONTROL.
- GRADING PERMIT.

- SEE HOWARD COUNTY STANDARD DETAILS NO'S G-1.01 AND G-1.02 FOR STANDARD SYMBOLS.
- HORIZONTAL COORDINATES ARE BASED ON MD NAD 83/91 DATUM AND VERTICAL ELEVATIONS ARE BASED ON NAVD 1988 ELEVATIONS, TRANSFERRED FROM N.G.S. AND HOWARD COUNTY CONTROL STATIONS:

COUNTY MONUMENT 47GC (HORIZONTAL AND VERTICAL)  
 N 528,939.75  
 E 1,354,223.5  
 ELEV. 226.27

COUNTY MONUMENT 47GA (HORIZONTAL ONLY) PID NO. A18508  
 N 532,404.18  
 E 1,351,627.37

- A STAGING AND STOCKPILE AREA WILL BE DETERMINED BY THE CONTRACTOR AND APPROVED BY THE HOWARD COUNTY ENGINEER.
- TOPOGRAPHY SURVEY INFORMATION BASED ON FIELD SURVEY PERFORMED BY JOHNSON, MIRMIRAN & THOMPSON DATED MAY 2005.
- UTILITY TEST HOLES PERFORMED BY KCITECHNOLOGIES, FEBRUARY 2006.
- DRAINAGE STRUCTURE STAKEOUT LOCATIONS:
  - STATIONS FOR TYPE 'S' COMBINATION INLETS ARE GIVEN TO THE GEOMETRIC CENTER OF THE STRUCTURE. OFFSETS ARE GIVEN TO THE FACE OF THE INLET HEADPIECE (FLOWLINE OF MODIFIED COMBINATION CURB AND GUTTER). TOP OF CURB (T.C.) ELEVATIONS ARE GIVEN TO THE TOP OF THE INLET HEADPIECE.
  - STATIONS FOR PRECAST STD. TYPE A-5 INLETS ARE GIVEN TO THE GEOMETRIC CENTER OF THE STRUCTURE. OFFSETS ARE GIVEN TO THE FACE OF THE CURB. TOP ELEVATIONS ARE GIVEN TO THE TOP OF CURB (T.C.).
  - STATIONS AND OFFSETS FOR 48" DIA. PRECAST MANHOLES ARE GIVEN TO THE GEOMETRIC CENTER OF THE STRUCTURE. TOP ELEVATIONS ARE GIVEN TO THE TOP OF MANHOLE RIM (T.R.).
  - COORDINATES OF INLETS, MANHOLES AND END SECTIONS ARE INCLUDED IN THE CONTRACT INVITATION TO BID BOOK.

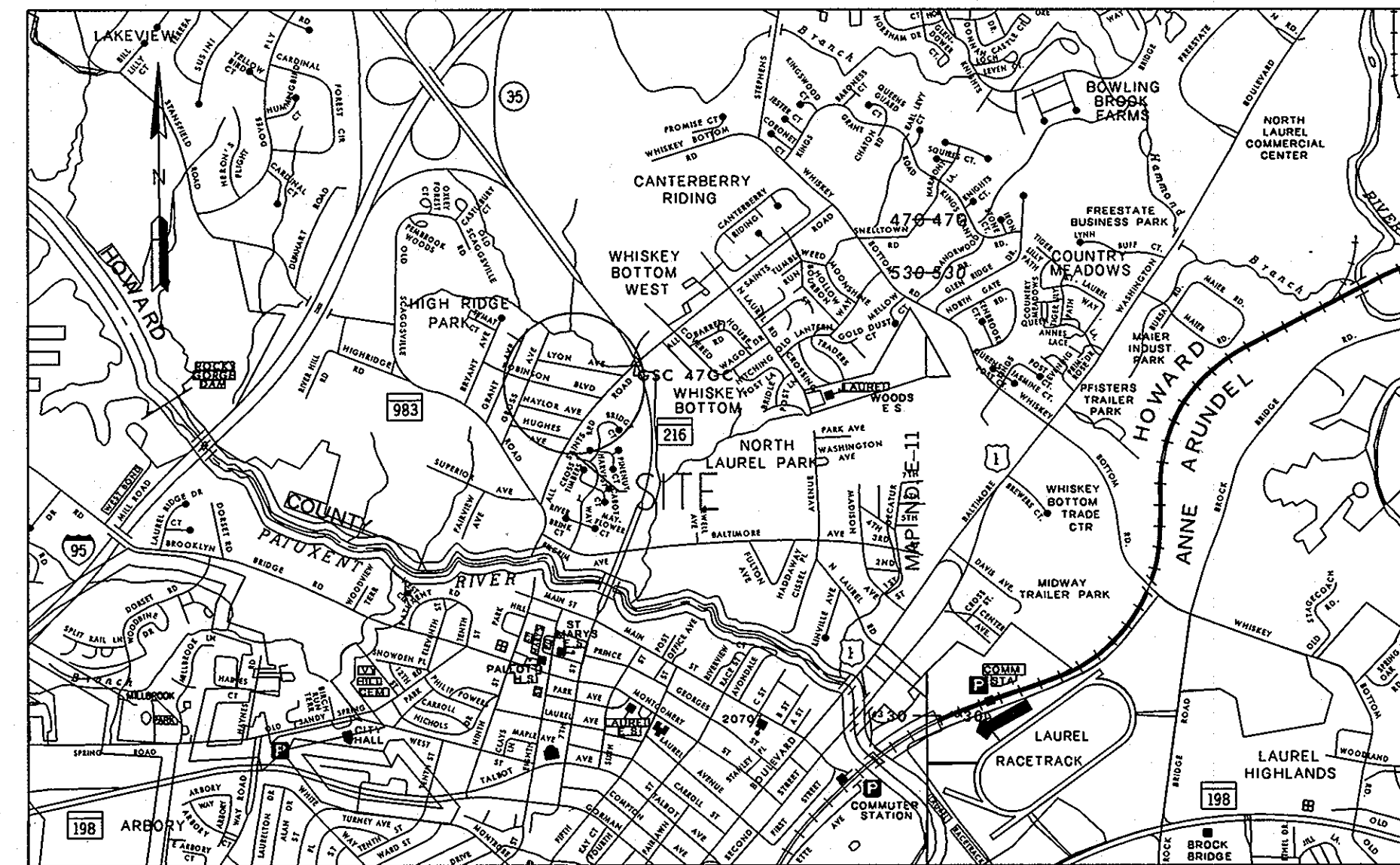

LOCATION MAP  
 SCALE 1" = 2000'

CAPITAL PROJECT NO. D-II43

# NAYLOR AVENUE AND ROBINSON BOULEVARD STORM DRAIN IMPROVEMENTS

HOWARD COUNTY, MARYLAND  
 DEPARTMENT OF PUBLIC WORKS

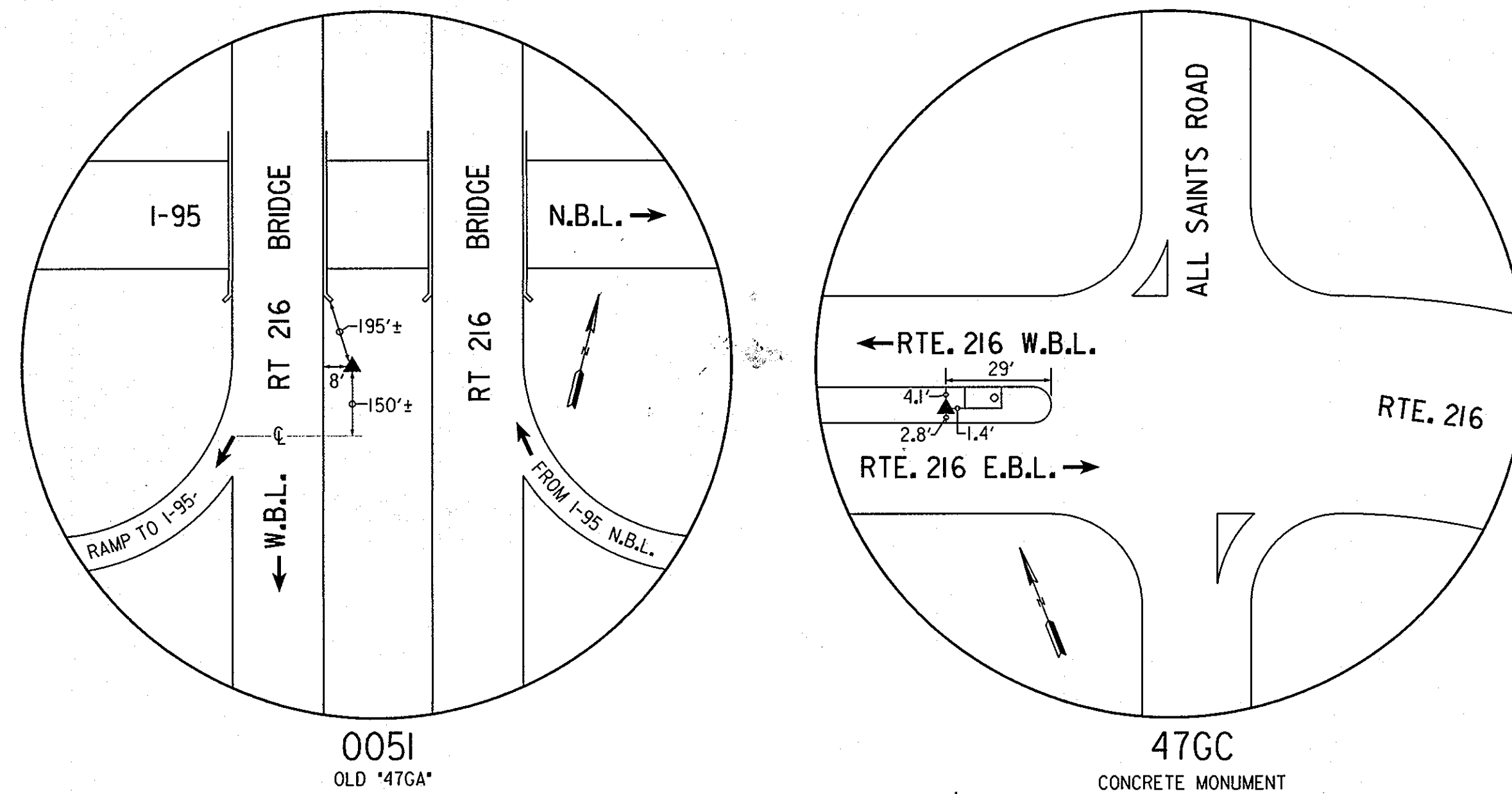

0051  
 OLD '47GA'

47GC  
 CONCRETE MONUMENT

HOWARD COUNTY SURVEY CONTROL

"PROFESSIONAL CERTIFICATION. I HEREBY CERTIFY THAT THESE DOCUMENTS WERE PREPARED OR APPROVED BY ME, AND THAT I AM A DULY LICENSED PROFESSIONAL ENGINEER UNDER THE LAWS OF THE STATE OF MARYLAND, LICENSE NO. 15446 EXPIRATION DATE: 07/15/09"

APPROVED: FOR STORM DRAINAGE SYSTEMS AND PUBLIC ROADS, HOWARD COUNTY DEPARTMENT OF PUBLIC WORKS  
*Steve Shanar* 3/11/08  
 CHIEF, DIVISION OF TRANSPORTATION AND SPECIAL PROJECTS DATE

THIS DEVELOPMENT IS APPROVED FOR EROSION AND SEDIMENT CONTROL BY THE HOWARD SOIL CONSERVATION DISTRICT.  
*John R. Kistner* 3/11/08  
 Howard Soil Conservation District DATE

FILE: G:\SNO\30662\_2840\proj\HOWARD\OR\_03062.dgn  
 DATE: 3/5/2008 10:30:23 AM

DEPARTMENT OF PUBLIC WORKS  
 HOWARD COUNTY, MARYLAND

*Steve Shanar* 3/11/08  
 DIRECTOR OF PUBLIC WORKS

*William S. Hall* 3-10-08  
 CHIEF, BUREAU OF HIGHWAYS

**JMPT**  
 JOHNSON, MIRMIRAN & THOMPSON  
 Engineering A Brighter Future  
 72 Loveton Circle, Baltimore, Maryland 21152-0949

STATE OF MARYLAND  
 PROFESSIONAL ENGINEER  
 JOHN M. THOMPSON  
 LICENSE NO. 15446 EXPIRES 07/15/09

DES:	SAM				
DRN:	JMB				
CHK:	PFC				
DATE:	MAR. 2008	BY	NO.		DATE

TITLE SHEET  
 NAYLOR AVENUE & ROBINSON BOULEVARD  
 - STORM DRAIN IMPROVEMENTS

CAPITAL PROJECT No. D-II43

SCALE: AS SHOWN  
 SHEET 1 OF 17

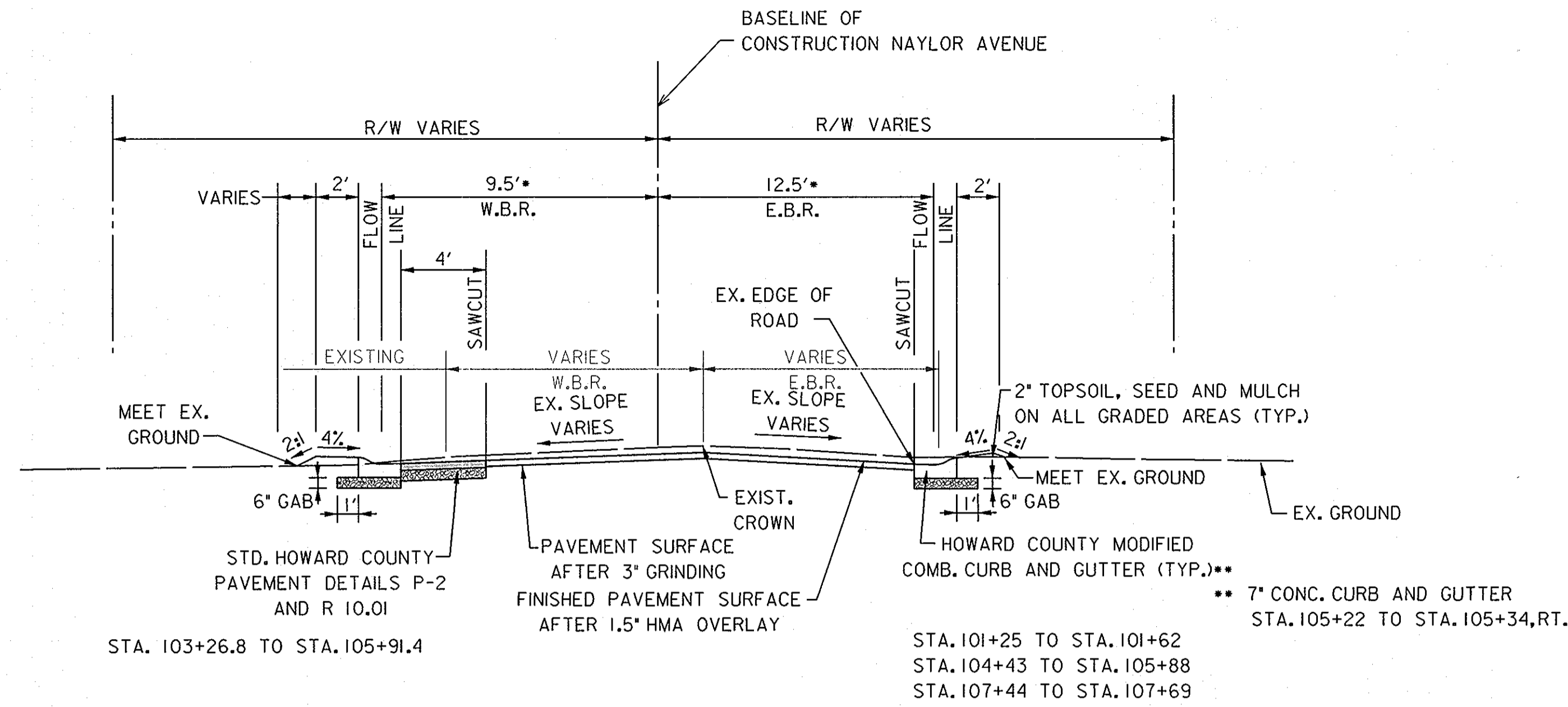

\*UNLESS SHOWN OTHERWISE ON THE PLANS AND IN CURB GEOMETRY SCHEDULE

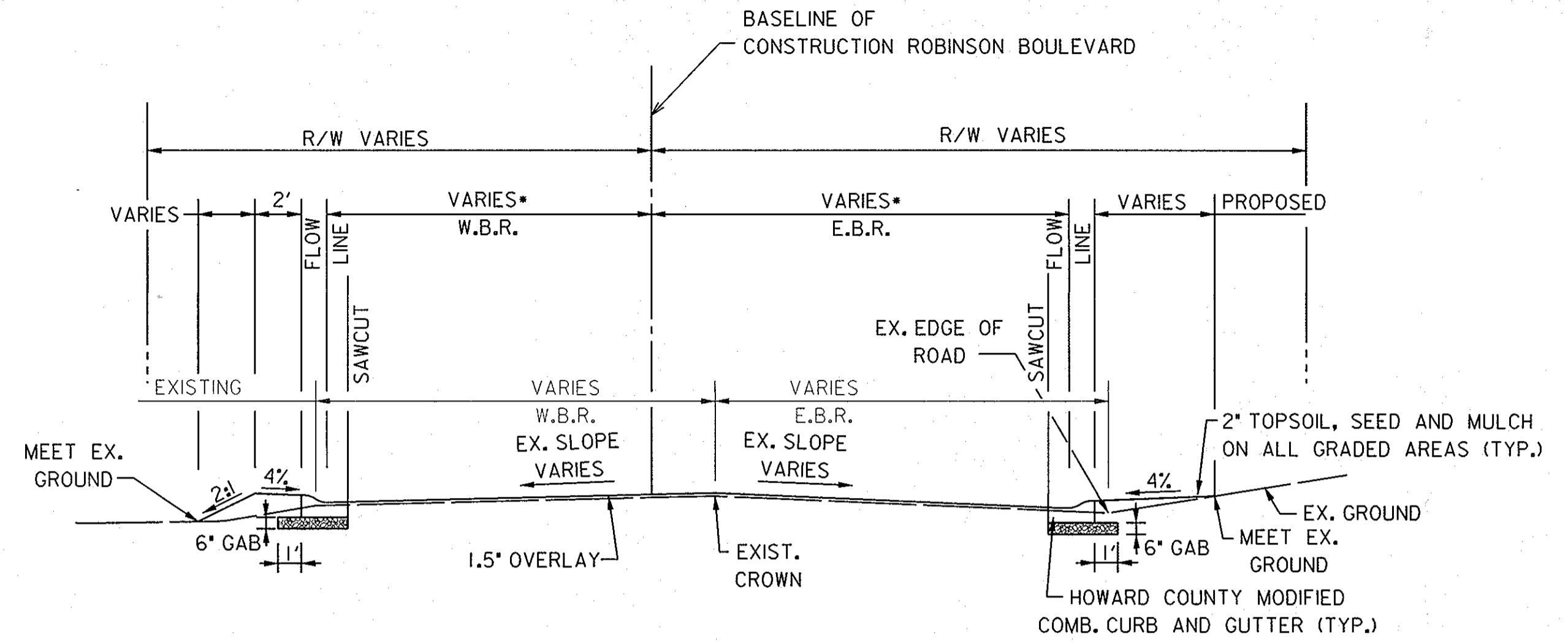

STA. 200+18.1 TO STA. 202+09  
STA. 207+56 TO STA. 210+05

STA. 200+05 TO STA. 201+03  
STA. 202+36 TO STA. 209+00  
STA. 209+75 TO STA. 210+05

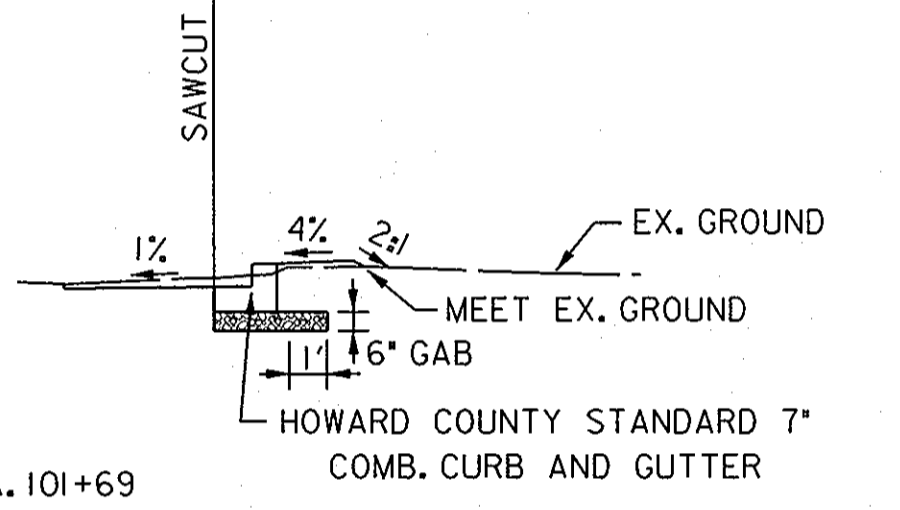

7" CURB AS SHOWN ON PS-1 - STA. 105+22 TO STA. 105+34  
- STA. 108+57 TO STA. 108+69

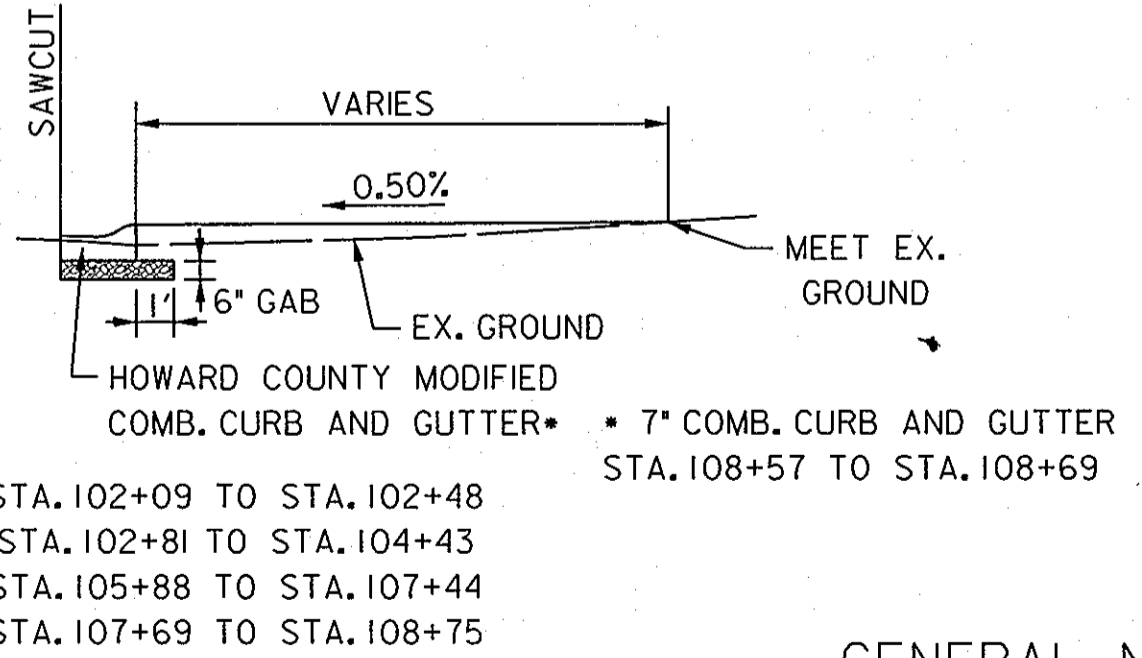
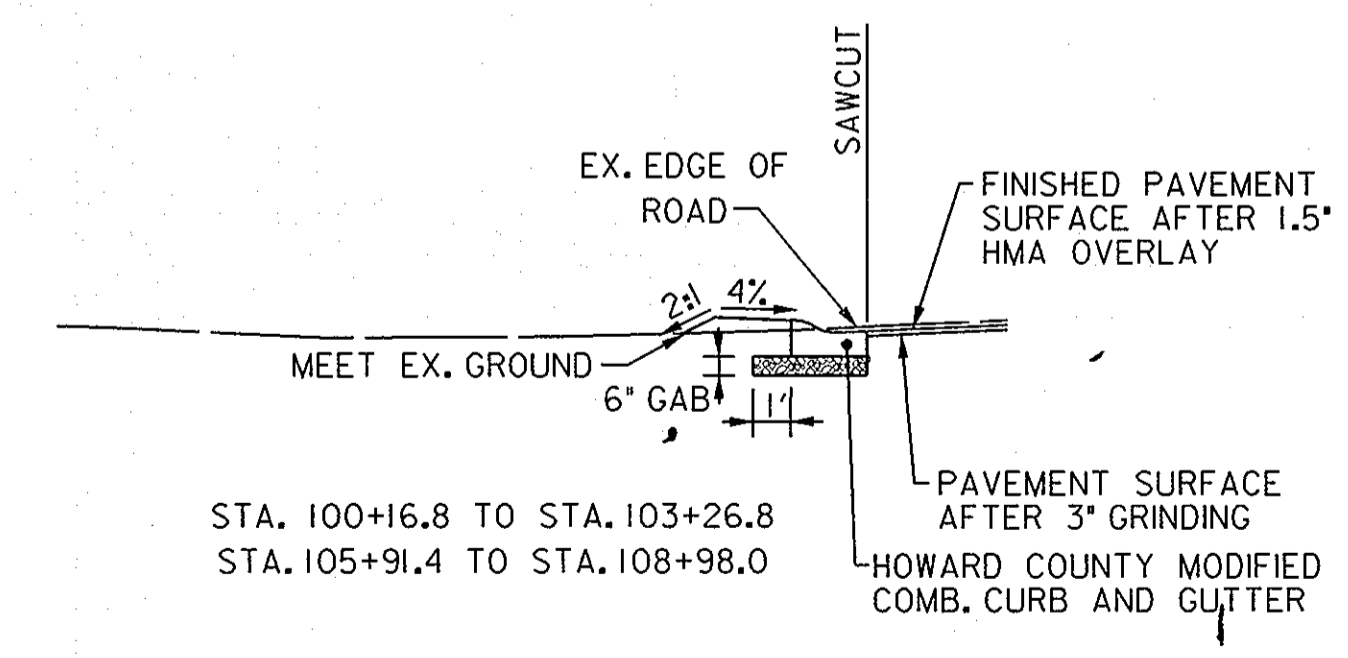
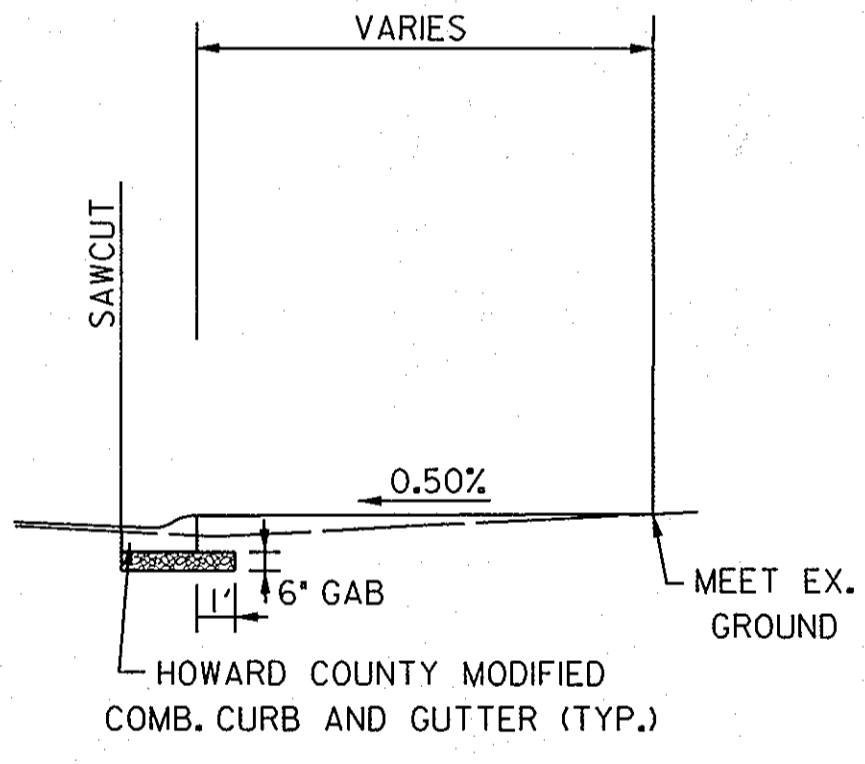
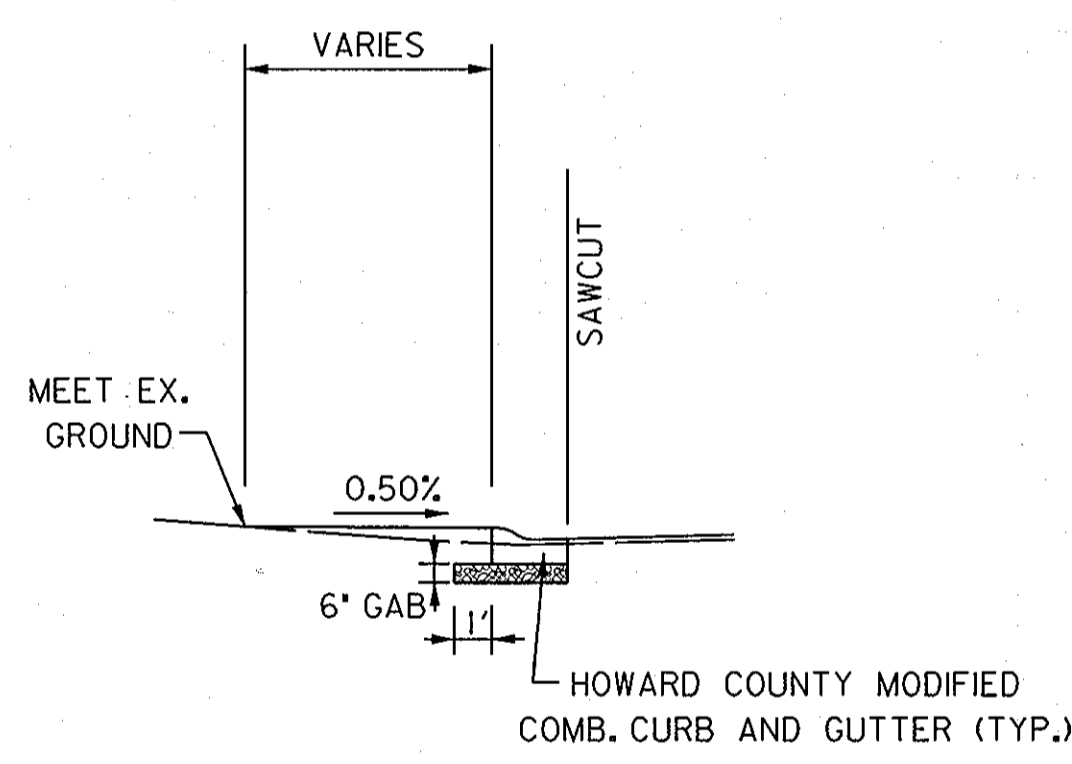
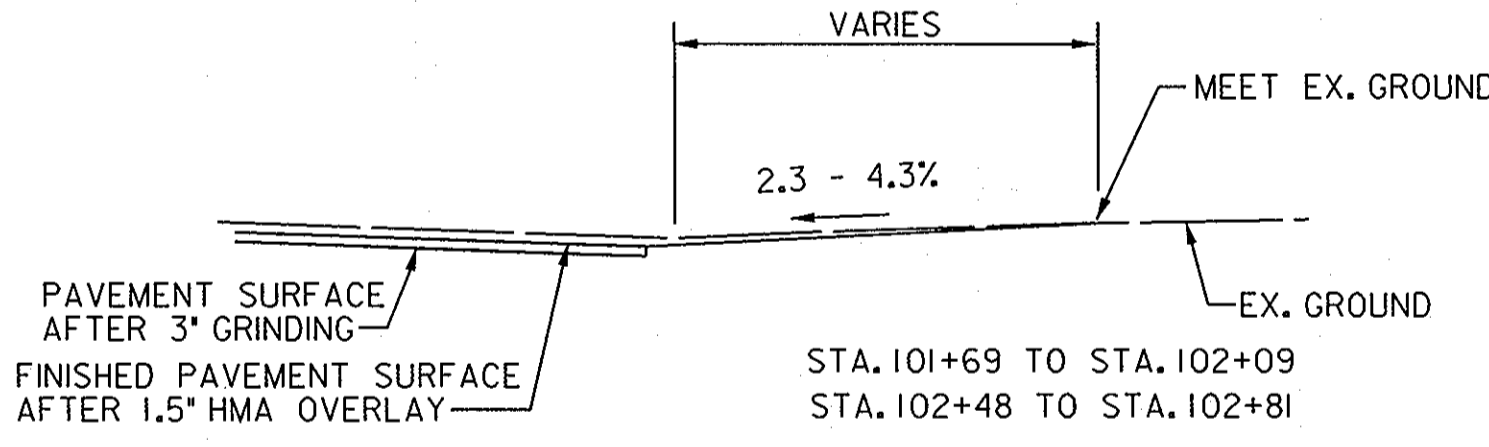
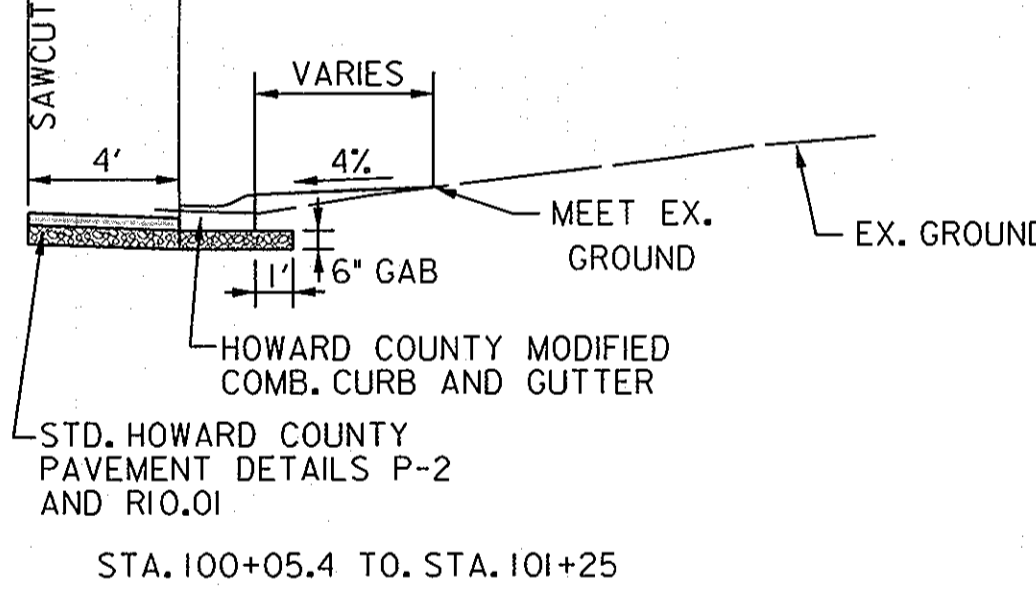

**NAYLOR AVENUE TYPICAL SECTION**

STA. 100+05 TO STA. 108+98

**ROBINSON BOULEVARD TYPICAL SECTION**

STA. 200+05 TO STA. 210+32

\*W.B.R. WIDTH VARIES FROM STA. 200+18.10 TO STA. 200+38.23 AND FROM STA. 207+01.60 TO STA. 207+36.05 AND FROM STA. 210+17.31 TO STA. 210+31.86, SEE CURB GEOMETRY ON PS-2 AND PS-3.  
W.B.R. WIDTH = 14' FROM STA. 200+38.23 TO STA. 207+01.60  
W.B.R. WIDTH = 15' FROM STA. 207+36.05 TO STA. 210+17.31  
E.B.R. WIDTH VARIES FROM STA. 200+05.31 TO STA. 200+29.05 AND FROM STA. 206+38.85 TO STA. 206+66.77, SEE CURB GEOMETRY SCHEDULE ON PS-2 AND PS-3.  
E.B.R. WIDTH = 18' FROM STA. 200+29.05 TO STA. 206+38.85  
E.B.R. WIDTH = 15' FROM STA. 206+66.77 TO STA. 210+05.11.

**GENERAL NOTE:**  
FOR DRIVEWAY TYPICAL SECTIONS  
SEE DRAWING TS-2

FILE: 811001300663\_20010101\_0001\_Naylor.dgn DATE: 3/7/2008 8:58:20 AM

DEPARTMENT OF PUBLIC WORKS  
HOWARD COUNTY, MARYLAND

*Steve Sharan* 3/10/08  
DIRECTOR OF PUBLIC WORKS

*William R. Williams* 3-10-08  
CHIEF, BUREAU OF HIGHWAYS

*John P. ...* 3/10/08  
CHIEF, BUREAU OF ENGINEERING

PROJECTS DIVISION

**JMT**  
JOHNSON, MIRMIRAN & THOMPSON  
Engineering A Brighter Future  
72 Loveton Circle Baltimore, Maryland 21152-0949

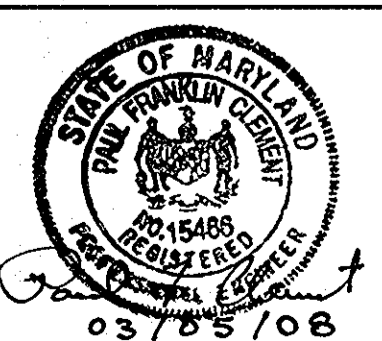

DES:	SAM				
DRN:	JMB				
CHK:	PFC				
DATE:	MAR. 2008	BY	NO.		DATE

TYPICAL SECTIONS  
**NAYLOR AVENUE & ROBINSON BOULEVARD**  
- STORM DRAIN IMPROVEMENTS

CAPITAL PROJECT No. D-1143

TS-1  
SCALE NONE  
SHEET 2 OF 17

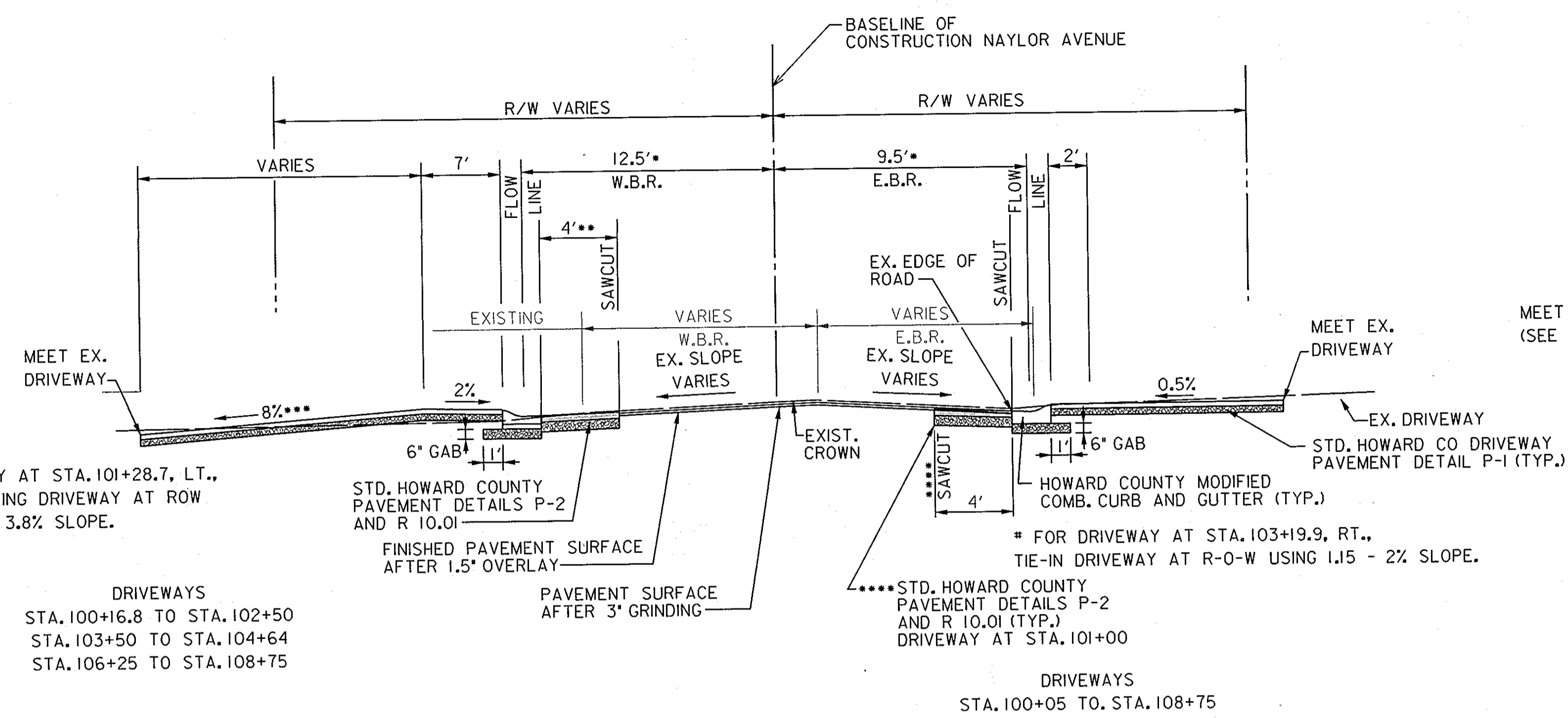

\*\*\* FOR DRIVEWAY AT STA.101+28.7, LT., TIE-IN TO EXISTING DRIVEWAY AT ROW USING 3.8% SLOPE.

DRIVEWAYS  
STA.100+16.8 TO STA.102+50  
STA.103+50 TO STA.104+64  
STA.106+25 TO STA.108+75

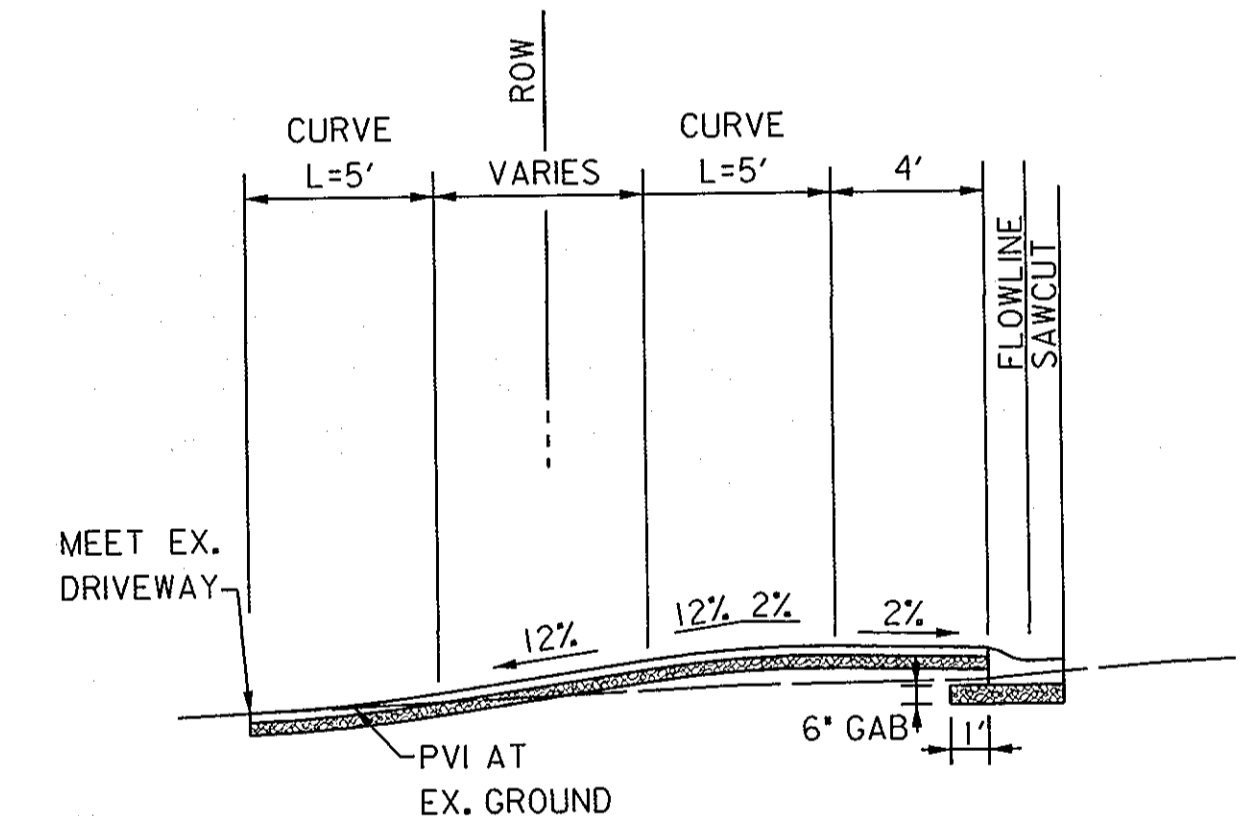

DRIVEWAYS  
STA.102+50 TO STA.103+50  
STA.104+64 TO STA.106+25

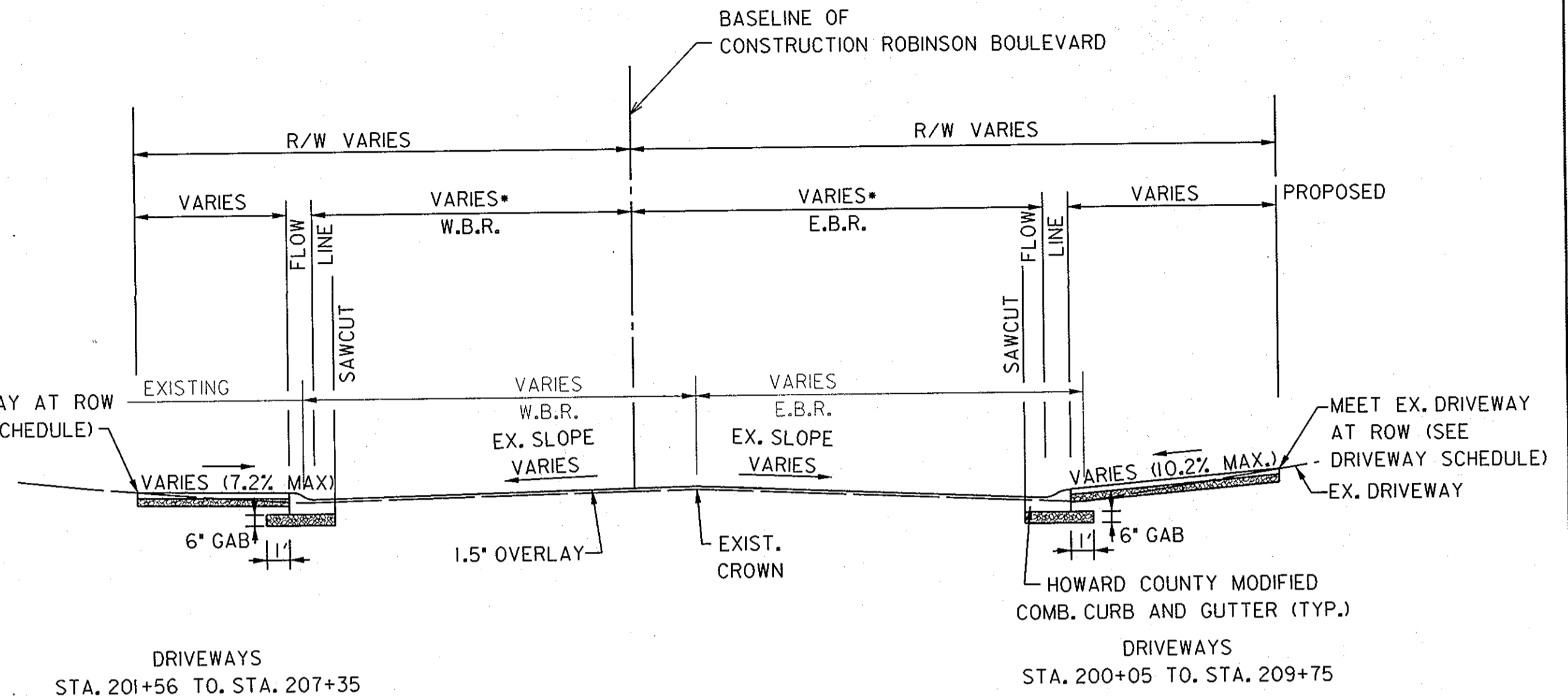

DRIVEWAYS  
STA.201+56 TO STA.207+35

DRIVEWAYS  
STA.200+05 TO STA.209+75

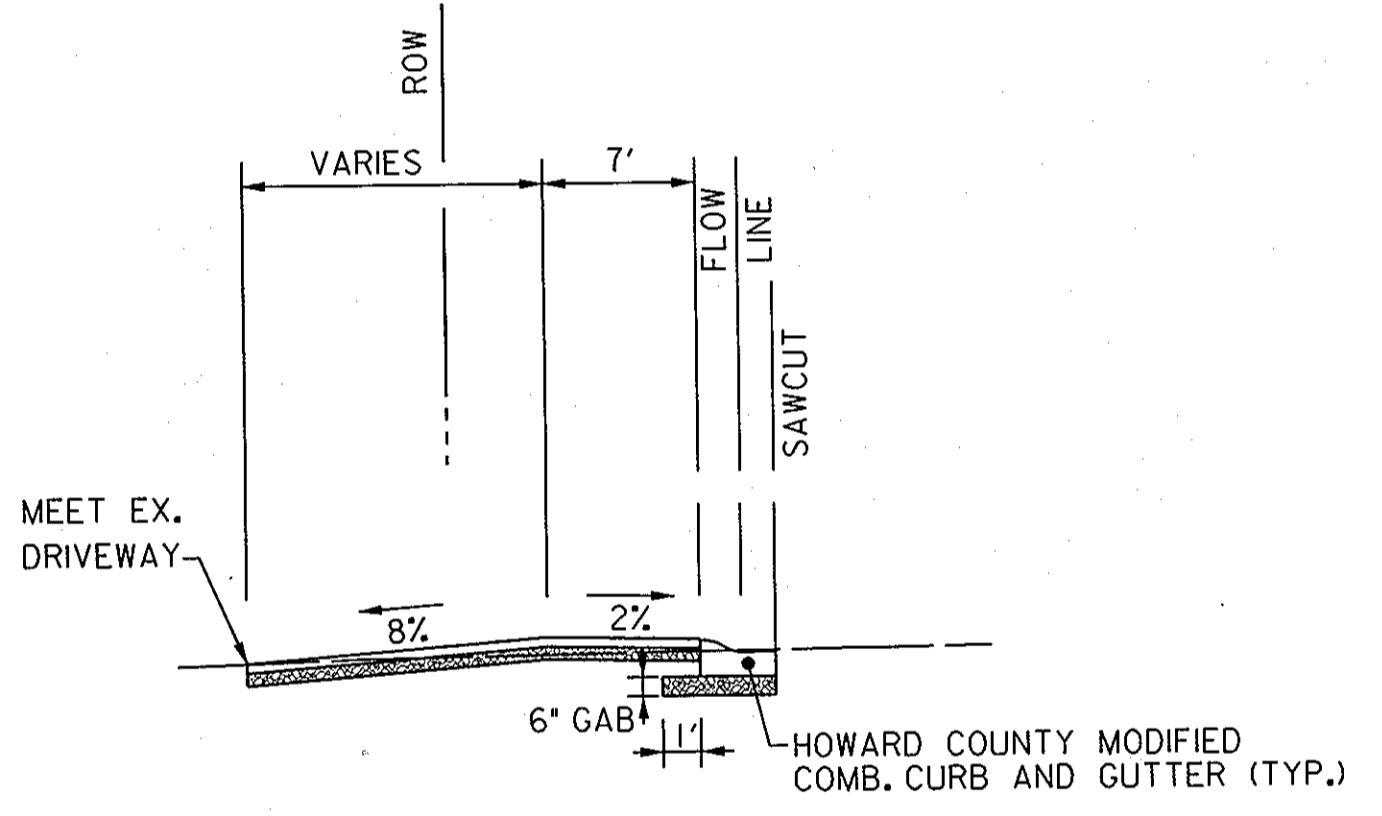

DRIVEWAYS  
STA.200+18.1 TO STA.201+56  
STA.207+35 TO STA.210+05

### NAYLOR AVENUE AT DRIVEWAYS TYPICAL SECTION

### ROBINSON BOULEVARD AT DRIVEWAYS TYPICAL SECTION

- UNLESS SHOWN OTHERWISE ON THE PLANS AND IN CURB GEOMETRY SCHEDULE
- FOR CONCRETE DRIVEWAYS, SEE STD. DETAIL R-6.03

- W.B.R. WIDTH VARIES FROM STA.200+18.10 TO STA.200+38.23 AND FROM STA.207+01.60 TO STA.207+36.05 AND FROM STA.210+17.31 TO STA.210+31.86, SEE CURB GEOMETRY ON PS-2 AND PS-3.
- W.B.R. WIDTH = 14' FROM STA.200+38.23 TO STA.207+01.60
- W.B.R. WIDTH = 15' FROM STA.207+36.05 TO STA.210+17.31
- E.B.R. WIDTH VARIES FROM STA.200+05.31 TO STA.200+29.05 AND FROM STA.206+38.85 TO STA.206+66.77, SEE CURB GEOMETRY SCHEDULE ON PS-2 AND PS-3.
- E.B.R. WIDTH = 18' FROM STA.200+29.05 TO STA.206+38.85
- E.B.R. WIDTH = 15' FROM STA.206+66.77 TO STA.210+05.11.

**PAVING LEGEND**

- FULL DEPTH HMA PAVEMENT
- GRADED AGGREGATE BASE

DEPARTMENT OF PUBLIC WORKS  
HOWARD COUNTY, MARYLAND

*Steve Shanar* 3/10/08  
DIRECTOR OF PUBLIC WORKS

*Charles J. O'Connell* 3/10/08  
CHIEF, BUREAU OF ENGINEERING

*William J. McNeil* 3-10-08  
CHIEF, BUREAU OF HIGHWAYS

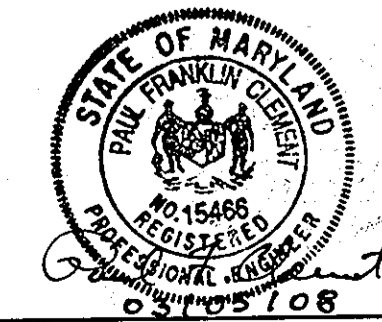

DES:	SAM	
DRN:	JMB	
CHK:	PFC	
DATE:	MAR. 2008	BY NO. DATE

TYPICAL SECTION  
**NAYLOR AVENUE & ROBINSON BOULEVARD  
- STORM DRAIN IMPROVEMENTS**

CAPITAL PROJECT No. D-1143

FILE: 910063.28.dwg PLOT: 3/27/08 2:14 PM

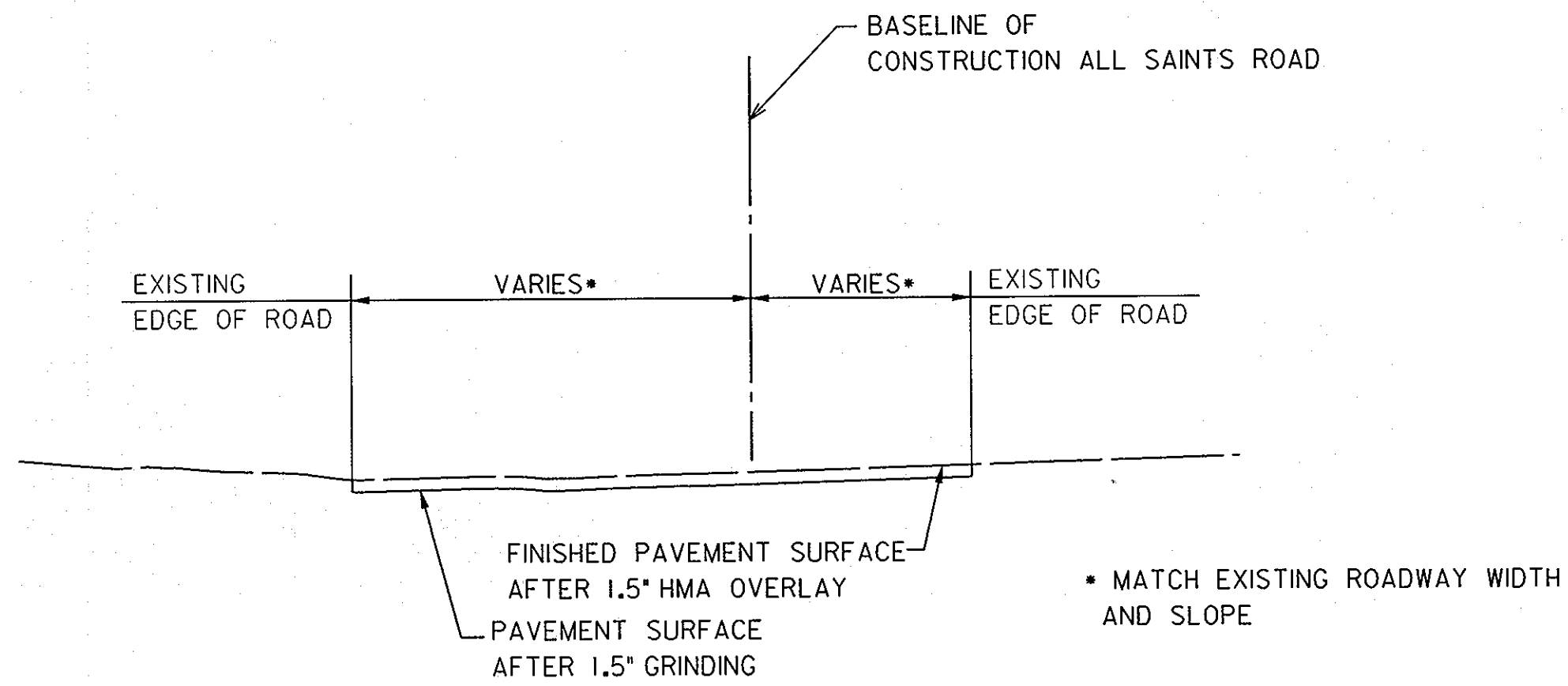

### ALL SAINTS ROAD TYPICAL SECTION

STA. 299+73 TO STA. 308+25  
NOT TO SCALE

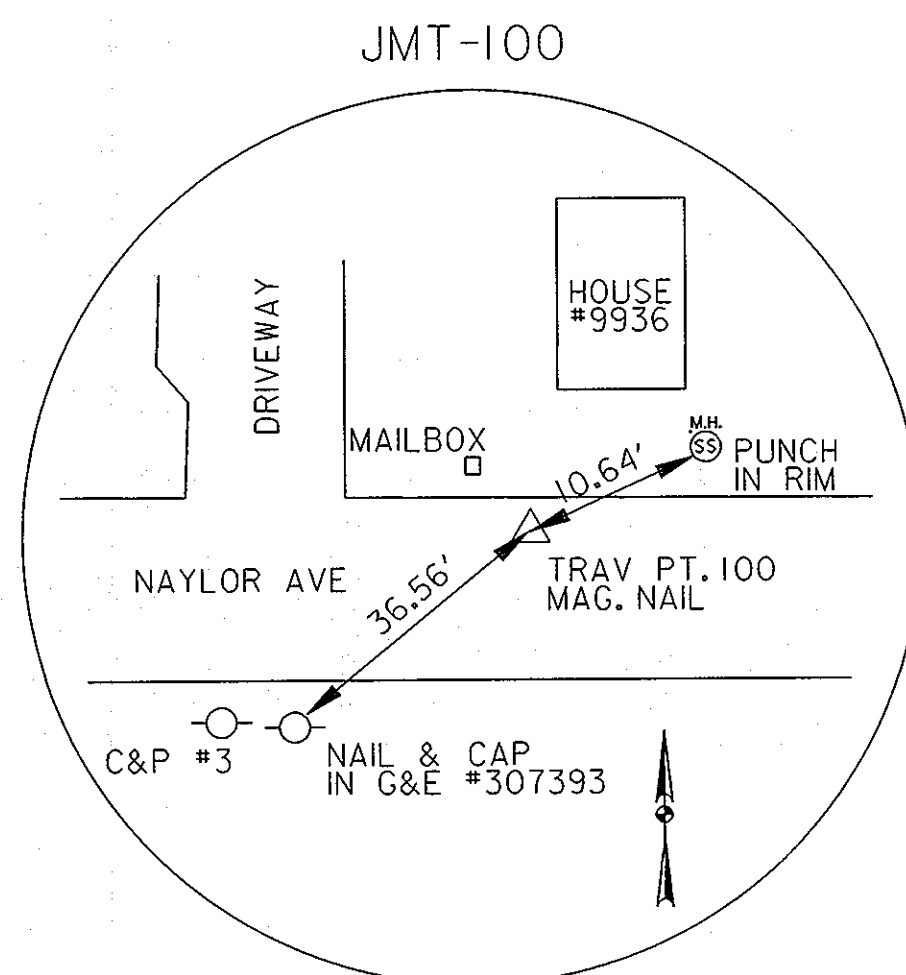
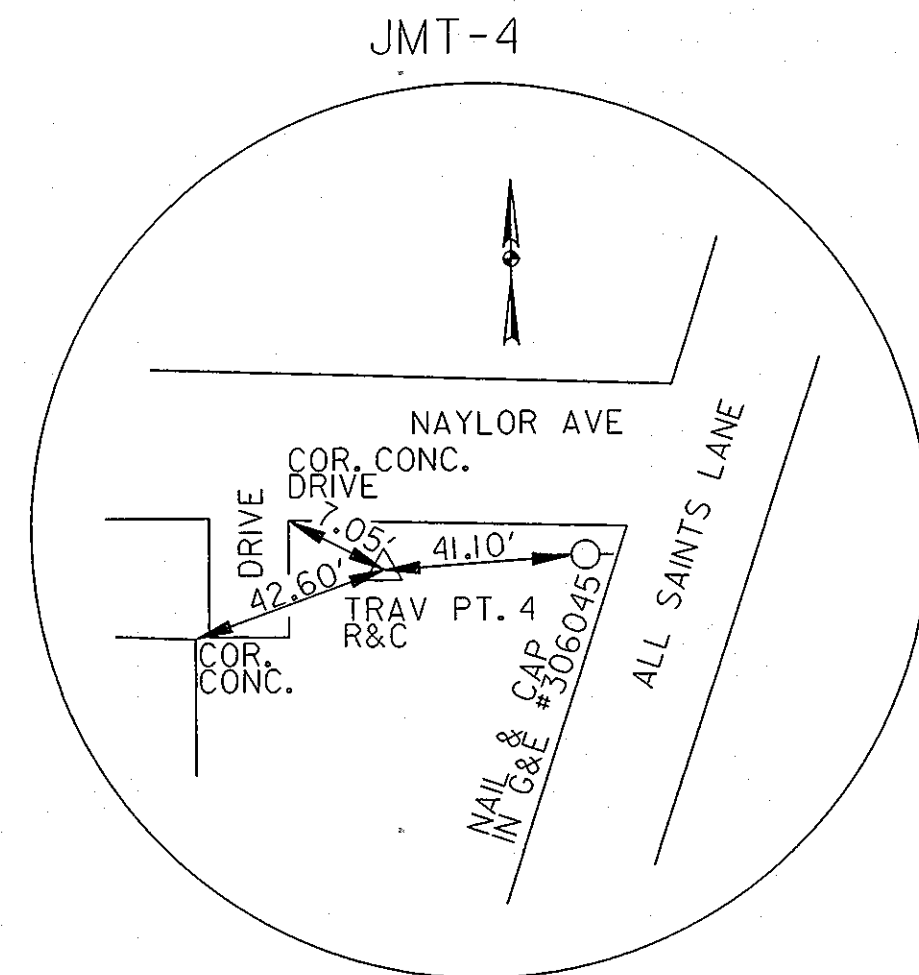
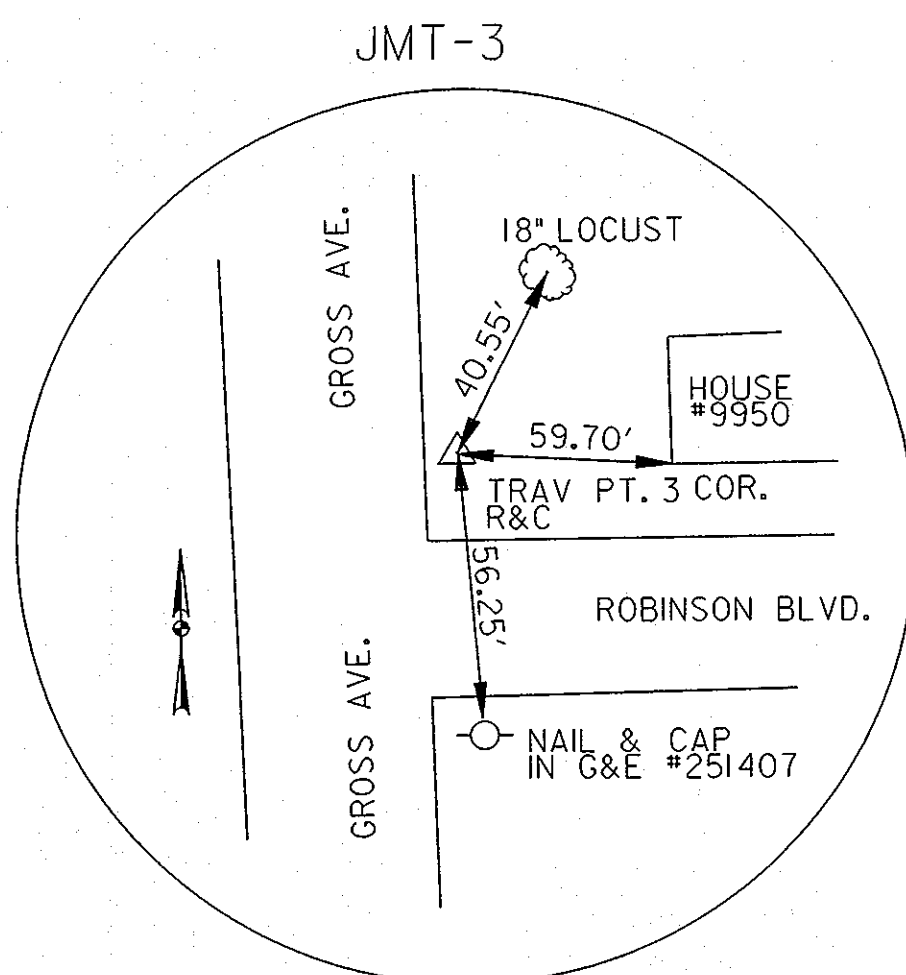

### SURVEY CONTROL POINTS (PS-1)

NOT TO SCALE

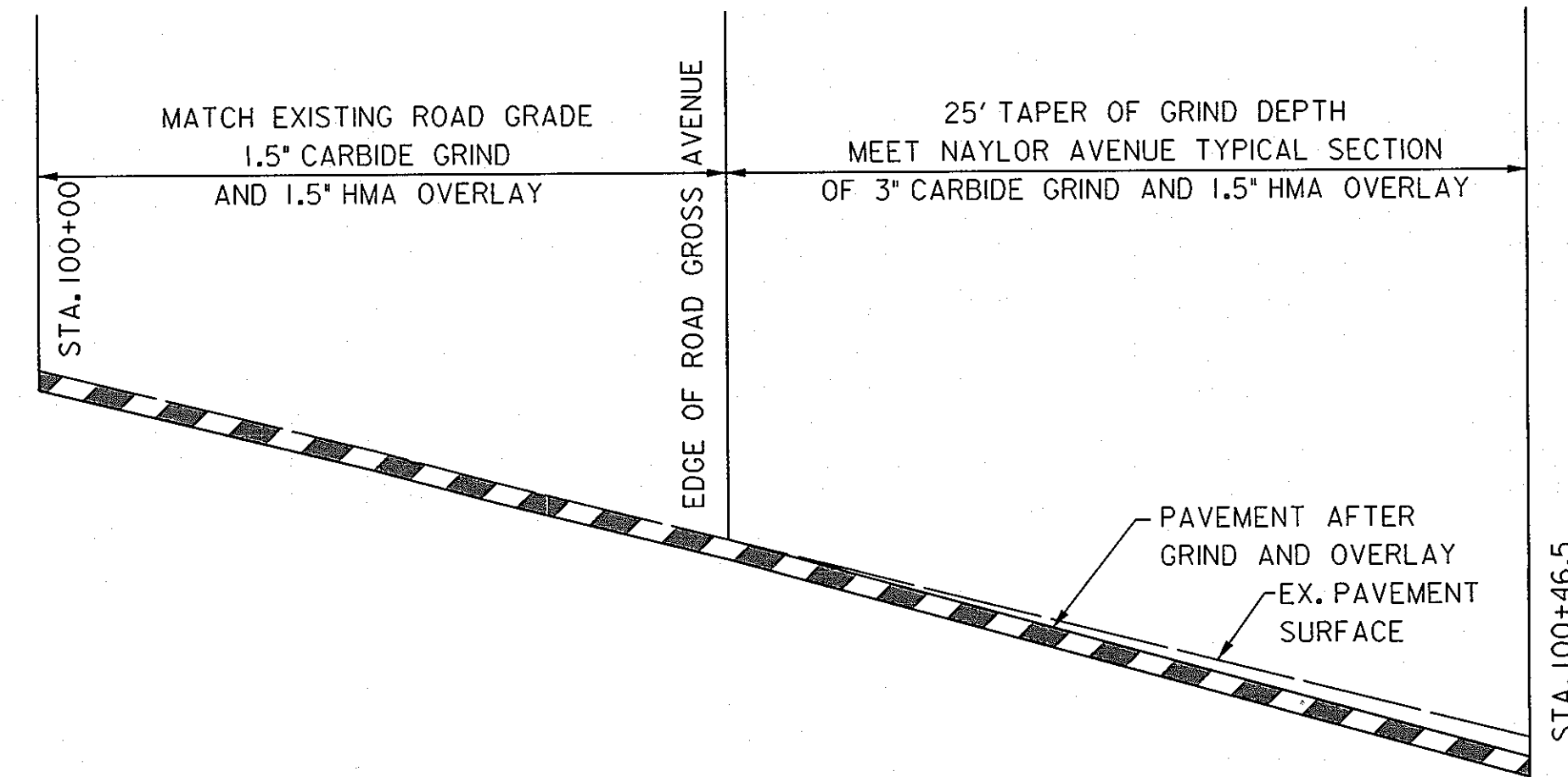

### NAYLOR AVENUE HEEL-IN DETAIL AT GROSS AVENUE

STA. 100+00 TO STA. 100+46.5  
NOT TO SCALE

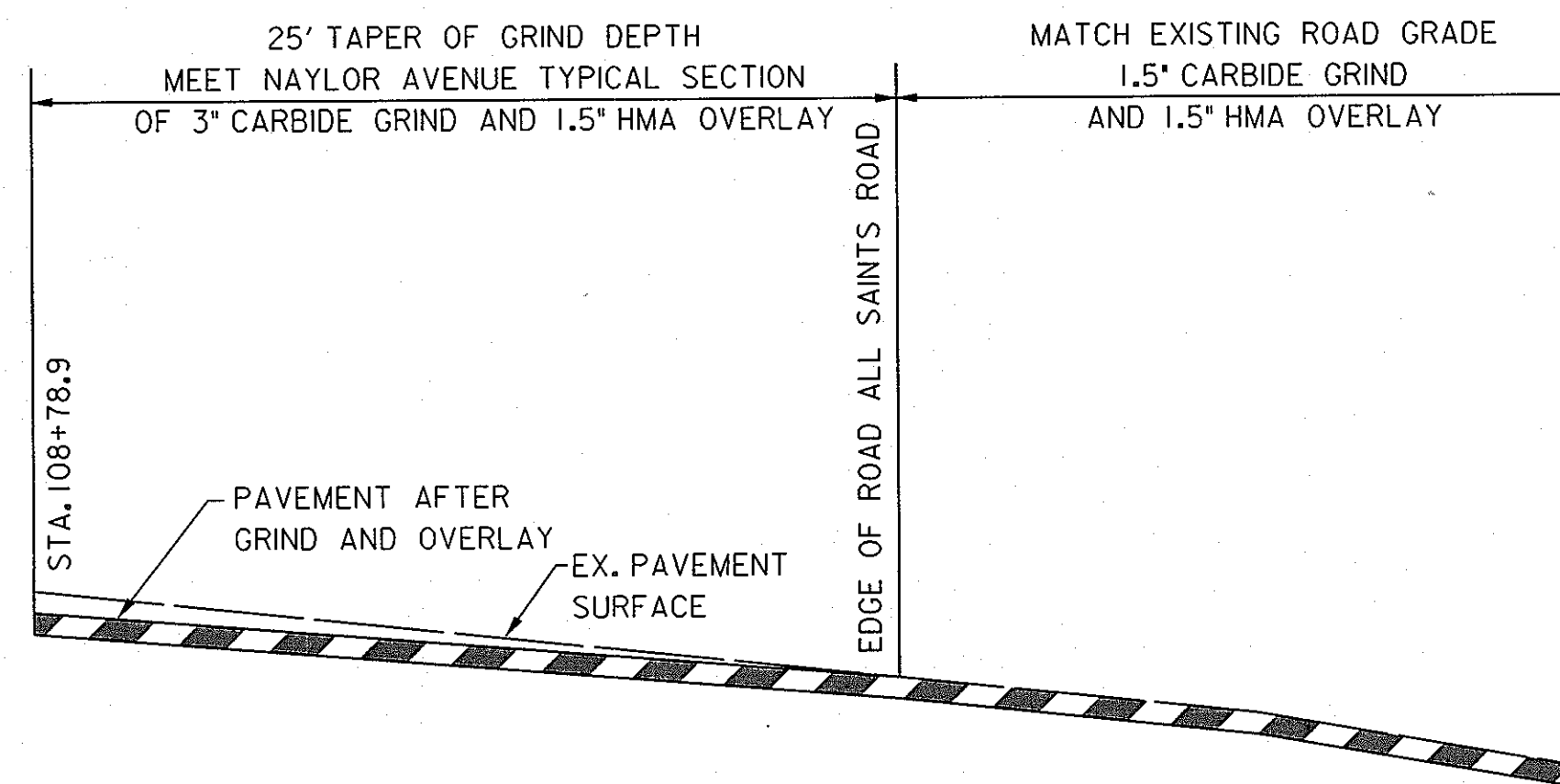

### NAYLOR AVENUE HEEL-IN DETAIL AT ALL SAINTS ROAD

STA. 108+78.9 TO ALL SAINTS ROAD  
NOT TO SCALE

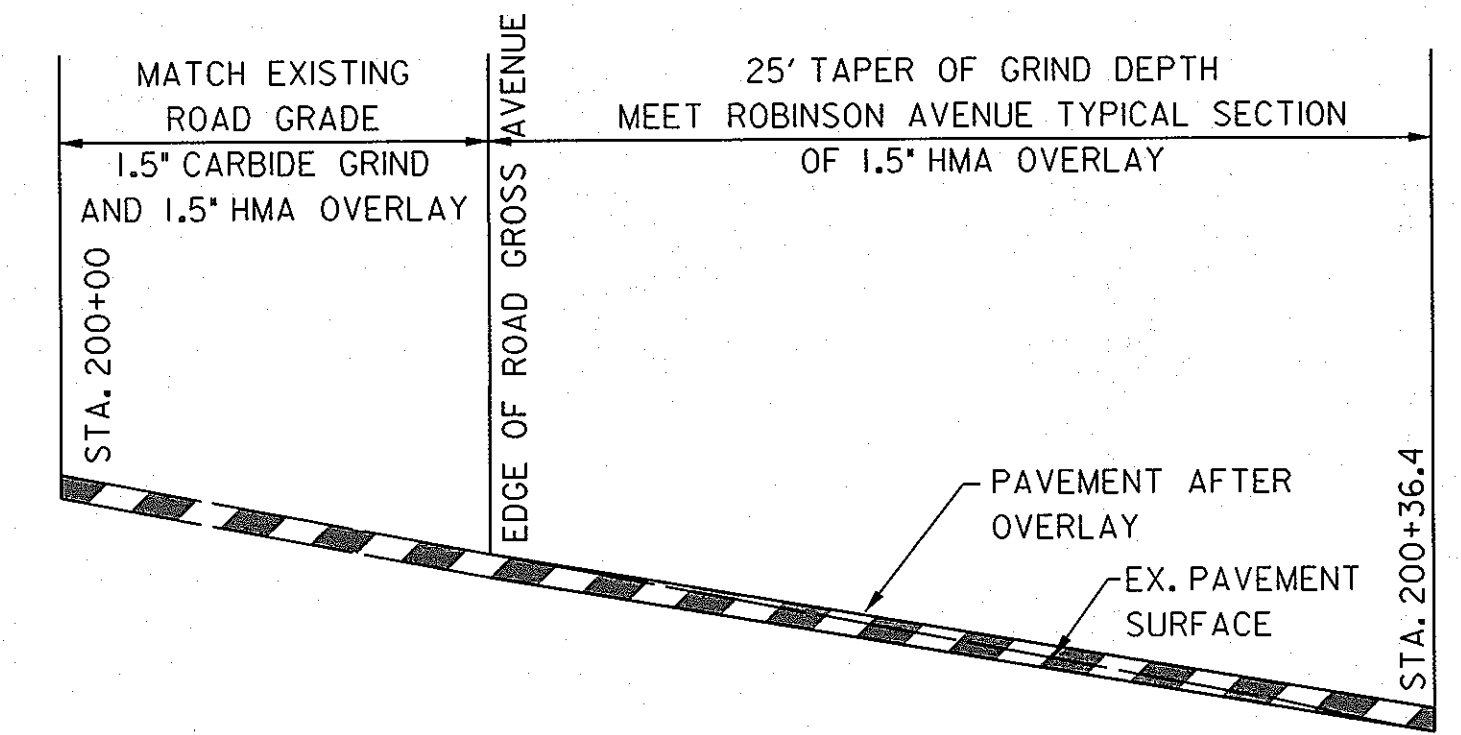

### ROBINSON BOULEVARD HEEL-IN DETAIL AT GROSS AVENUE

STA. 200+00 TO STA. 200+36.4  
NOT TO SCALE

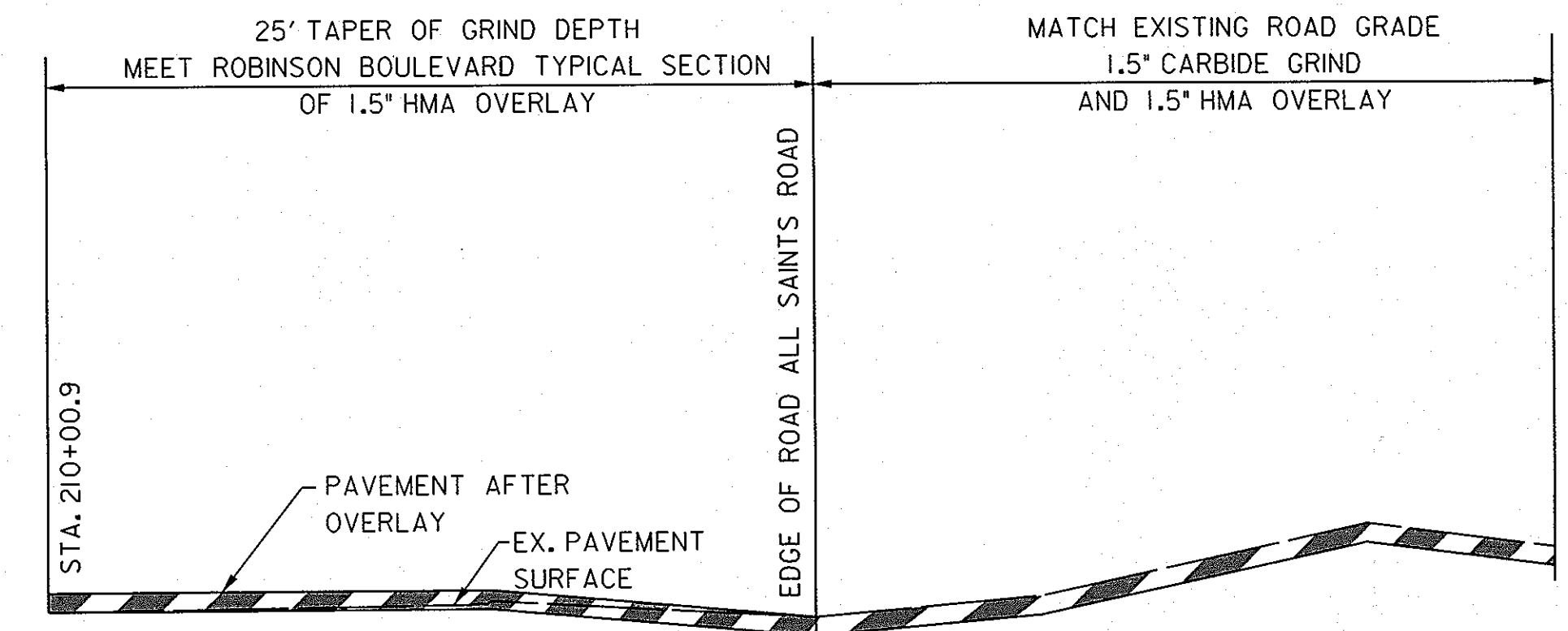

### ROBINSON BOULEVARD HEEL-IN DETAIL AT ALL SAINTS ROAD

STA. 210+00.9 TO ALL SAINTS ROAD  
NOT TO SCALE

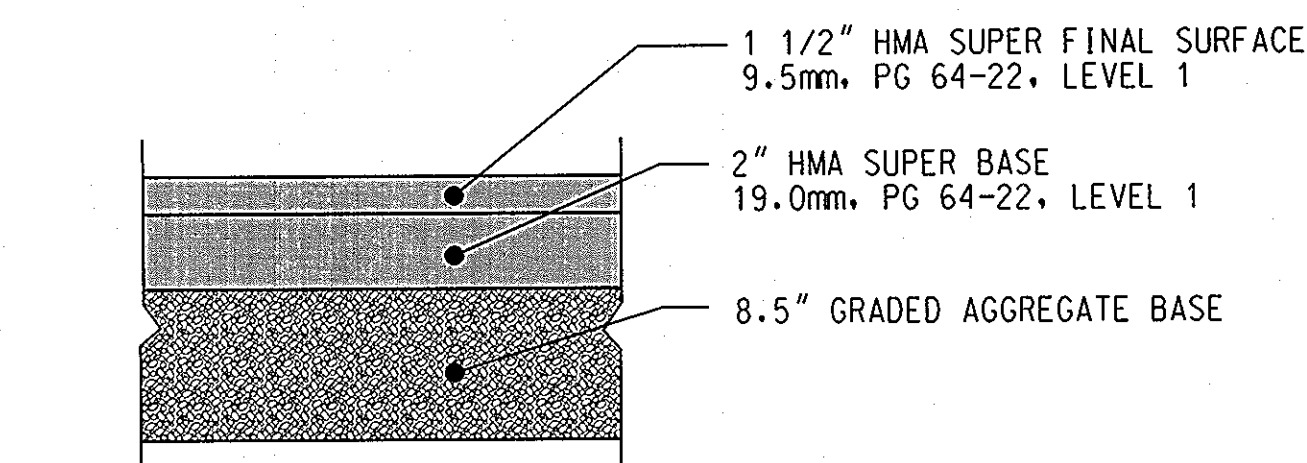

PAVEMENT DETAIL P-1

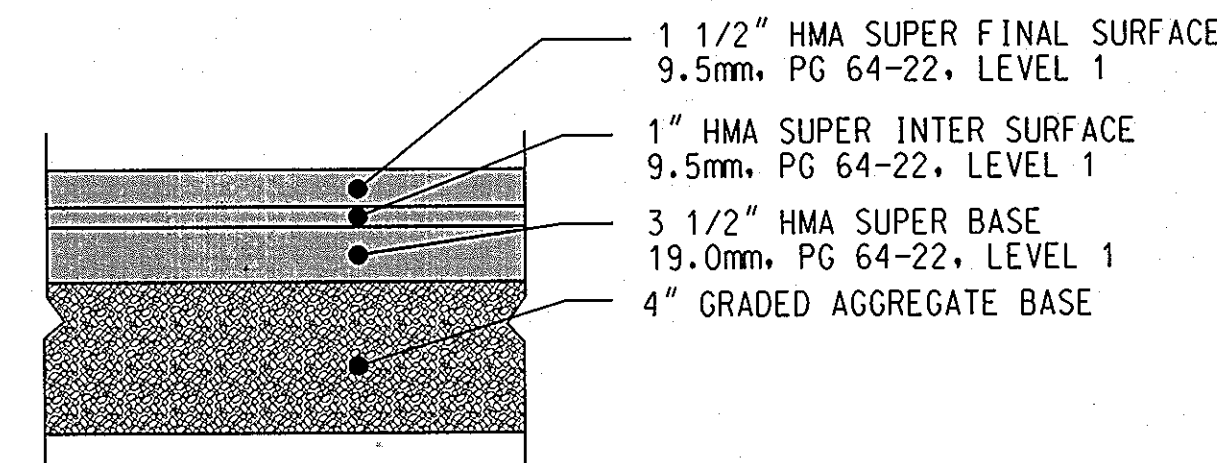

PAVEMENT DETAIL P-2

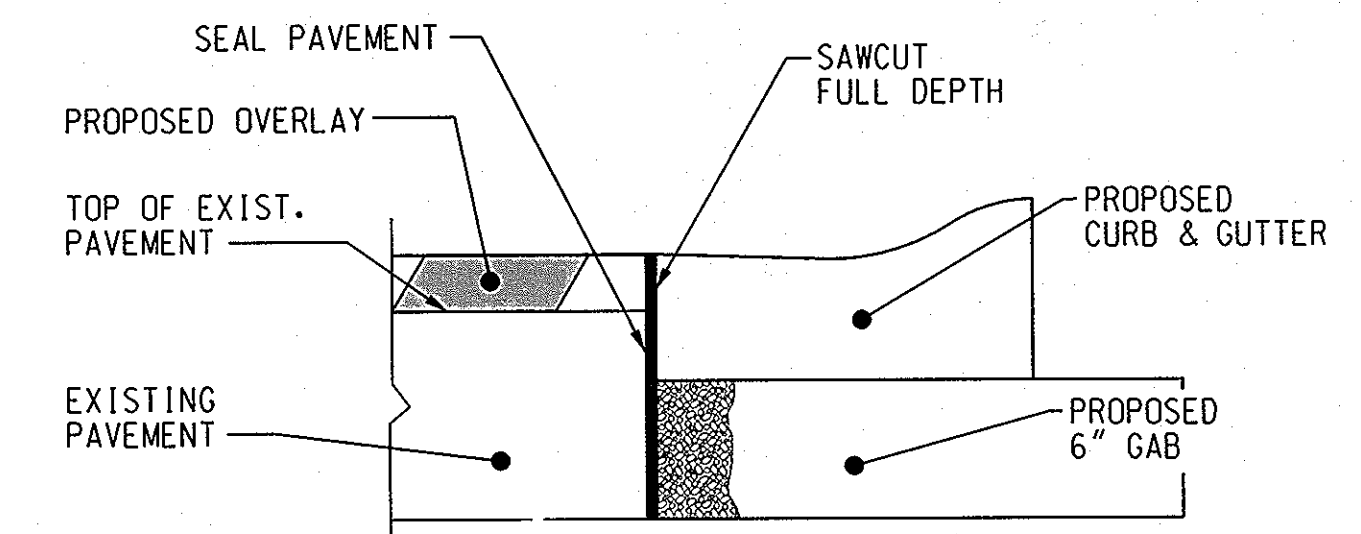

TYPICAL PAVEMENT JOINT B  
(ADJACENT TO NEW CURB)

### PAVEMENT DETAILS

DEPARTMENT OF PUBLIC WORKS  
HOWARD COUNTY, MARYLAND

*Steve Shaner* 3/10/08  
DIRECTOR OF PUBLIC WORKS  
PROJECTS DIVISION

*Paul J. Shaner* 3/10/08  
CHIEF, BUREAU OF ENGINEERING

*William J. Shaner* 3-10-08  
CHIEF, BUREAU OF HIGHWAYS

**JMT**  
JOHNSON, MIRMIRAN & THOMPSON  
Engineering. A Brighter Future  
72 Lovston Circle, Baltimore, Maryland 21152-0949

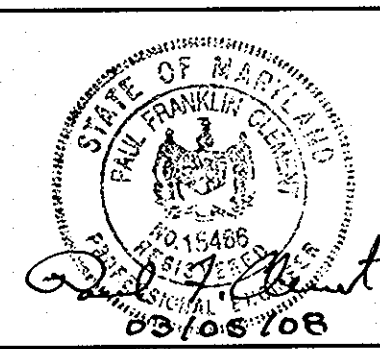

DES:	SAM			
DRN:	JMB			
CHK:	PFC			
DATE:	MAR. 2008	BY:	NO.	DATE:

TYPICAL SECTIONS AND ROADWAY DETAILS  
NAYLOR AVENUE & ROBINSON BOULEVARD  
- STORM DRAIN IMPROVEMENTS  
CAPITAL PROJECT No. D-1143

TS-3

SCALE  
NONE

SHEET

4 OF 17

PIPE SCHEDULE			
FROM	TO	TYPE	LENGTH
I-4	M-1	15" RCP, CL IV	2 L.F.
I-1	M-1	15" RCP, CL IV	11 L.F.
M-1	M-2	18" RCP, CL IV	238 L.F.
I-5	M-2	18" RCP, CL IV	2 L.F.
I-2	M-2	15" RCP, CL IV	19 L.F.
M-2	M-3	18" RCP, CL IV	330 L.F.
I-3	M-3	15" RCP, CL IV	14 L.F.
I-6	M-3	15" RCP, CL IV	4 L.F.
M-3	M-4	18" RCP, CL IV	45 L.F.
M-4	M-5	18" RCP, CL IV	197 L.F.

DRAINAGE STRUCTURE SCHEDULE					
NO.	STATION	OFFSET	TYPE	SD NO.	DEPTH
I-1	102+86.0	12.5, RT.	TYPE S COMB. INLET	SD 4.32	3.47'
I-2	105+28.0	17.1, RT.	PRECAST STD. TYPE A-5 INLET	SD 4.40	4.24'
I-3	108+63.0	12.1, RT.	PRECAST STD. TYPE A-5 INLET	SD 4.40	4.06'
I-4	102+86.0	9.5, LT.	TYPE S COMB. INLET	SD 4.32	3.60'
I-5	105+28.0	9.5, LT.	TYPE S COMB. INLET	SD 4.32	3.91'
I-6	108+61.0	11.3, LT.	TYPE S COMB. INLET	SD 4.32	3.59'
M-1	102+86.0	3.0, LT.	48" DIA. SHALLOW PRECAST MANHOLE	G 5.12	4.00'
M-2	105+28.0	3.2, LT.	48" DIA. SHALLOW PRECAST MANHOLE	G 5.12	4.23'
M-3	108+61.6	3.1, LT.	48" DIA. SHALLOW PRECAST MANHOLE	G 5.12	3.83'
M-4	300+02.0	5.5, LT.	48" DIA. STANDARD PRECAST MANHOLE	G 5.12	5.67'

BASELINE CONTROL COORDINATES			
LOCATION	STATION	EASTING	NORTHING
BASELINE OF CONSTRUCTION	POT STA. 100+00.00	1,352,631.54	528,246.86
NAYLOR AVENUE	POT STA. 109+13.94	1,353,526.01	528,059.19
BASELINE OF CONSTRUCTION	POT STA. 299+50.00	1,353,492.31	528,022.26
ALL SAINTS ROAD	POT STA. 308+50.00	1,354,098.88	528,687.14

SURVEY CONTROL POINTS (SEE SKETCHES ON DWG. TS-3)				
NO.	EASTING	NORTHING	ELEV.	DESC.
JMT-3	1,352,666.21	528,278.91	262.57	R&C (GPS)
JMT-4	1,353,453.56	528,053.96	250.76	R&C (GPS)
JMT-100	1,353,117.84	528,152.25	253.53	MAG. NAIL

CURB GEOMETRY SCHEDULE							
POINT NO.	FROM		TO		CURVE RADIUS	LENGTH	
	LOCATION	POINT NO.	LOCATION	POINT NO.			
C1	100+05.44	28.85' RT.	C2	100+06.65	23.93' RT.	---	5.1'
C2	100+06.65	23.93' RT.	C3	100+21.22	12.50' RT.	15'	20.0'
C3	100+21.22	12.50' RT.	C11	101+62.25	12.94' RT.	---	141.0'
C12	102+09.16	19.1' RT.	C13	102+48.34	19.1' RT.	---	39.2'
C14	102+80.78	12.50' RT.	C4	108+19.97	12.50' RT.	---	543.6'
C4	108+19.97	12.50' RT.	C5	108+75.32	11.47' RT.	---	55.4'
C6	100+16.78	34.18' LT.	C7	100+37.61	9.5' LT.	21'	36.9'
C7	100+37.61	9.5' LT.	C8	108+19.45	9.5' LT.	---	781.8'
C8	108+19.45	9.5' LT.	C9	108+76.71	12.12' LT.	---	57.3'
C9	108+76.71	12.12' LT.	C10	108+97.97	17.70' LT.	60'	22.1'

UTILITY TEST PIT SCHEDULE			
NO.	LOCATION	UTILITY	DEPTH
TP 1-1	STA. 102+54, 14J RT.	6" WATER	3.98'
TP 1-2	STA. 105+59, 14.3 RT.	6" WATER	3.91'
TP 1-3	STA. 108+65, 22.6 RT.	1 3/4" GAS	3.00'
TP 1-4	STA. 108+64, 11.8 RT.	6" WATER	4.70'
TP 1-5	STA. 108+97, 6.2 LT.	6" ELECTRIC	3.71'
TP 1-6	STA. 104+61, 2.4 LT.	3/4" ELECTRIC	3.49'

- NOTES:**
- LOCATIONS AND LENGTHS ARE GIVEN ALONG MODIFIED COMBINATION CURB AND GUTTER AT FLOW LINE.
  - SEE DETAIL ON PP-3 FOR CURB LAYOUT AT PROPOSED INLET I-2.
  - SEE STD. DETAIL R-3.06 FOR TRANSITION TO STD. 7" COMBINATION CURB AND GUTTER AT TYPE 'A-5' INLETS.

**TREE NOTE:**  
ALL TREES AND SHRUBS WITHIN THE LOD ARE TO REMAIN IN PLACE AND UNHARMED; UNLESS OTHERWISE DIRECTED BY THE COUNTY ENGINEER.

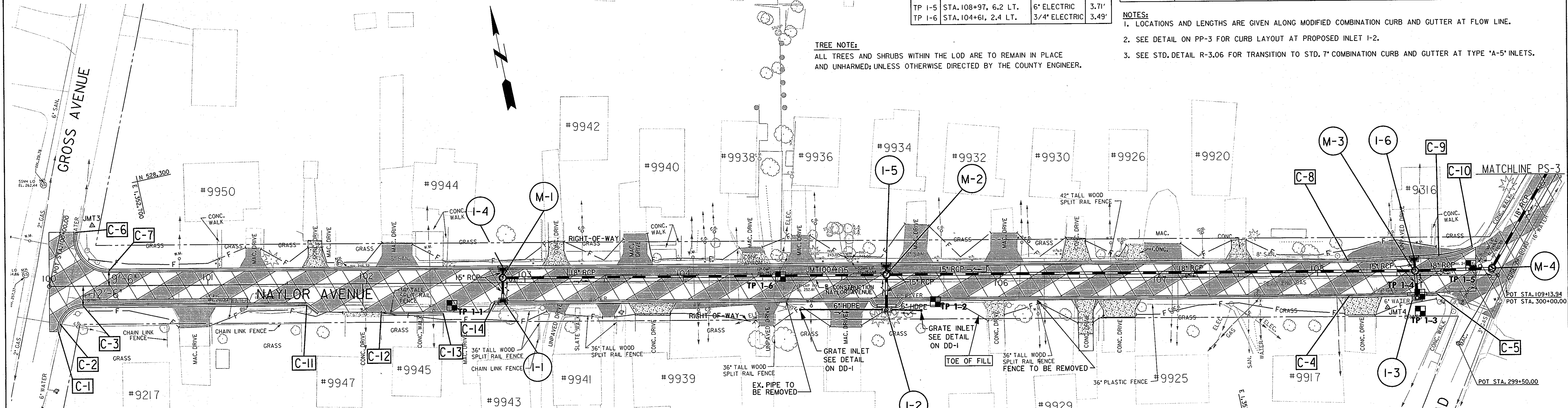

QUANTITY (S.Y.)	LOCATION	OFFSET @ TIE-IN	COMMENTS
20	101+67.81, LT.	27.5, LT.	HOUSE NO. 9950
7	101+97.62, RT.	20.8, RT.	HOUSE NO. 9947
20	103+19.93, LT.	26.0, LT.	HOUSE NO. 9942
23	103+80.40, RT.	21.5, RT.	HOUSE NO. 9939
14	104+44.37, LT.	17.6, LT.	HOUSE NO. 9938
17	105+95.85, RT.	26.5, RT.	HOUSE NO. 9931
25	106+47.61, LT.	25.4, LT.	HOUSE NO. 9930
26	106+53.68, RT.	35.4, RT.	HOUSE NO. 9929
28	106+74.88, RT.	25.0, RT.	HOUSE NO. 9925
15	106+85.66, LT.	21.2, LT.	HOUSE NO. 9926
16	107+50.51, LT.	23.5, LT.	HOUSE NO. 9920
29	108+26.98, RT.	24.7, RT.	HOUSE NO. 9917

LOCATION	OFFSET @ TIE-IN	COMMENTS
100+91.40, RT.	26.8, RT.	HOUSE NO. 9217
101+28.72, LT.	23.5, LT.	HOUSE NO. 9950
102+19.48, LT.	26.1, LT.	HOUSE NO. 9944
102+62.37, RT.	25.9, RT.	HOUSE NO. 9943
103+19.93, RT.	19.3, RT.	HOUSE NO. 9941
103+50.00, RT.	22.5, RT.	HOUSE NO. 9941
103+69.61, LT.	30.5, LT.	HOUSE NO. 9940
104+44.37, LT.	21.6, LT.	HOUSE NO. 9938
104+52.26, RT.	29.0, RT.	HOUSE NO. 9933
104+73.75, LT.	28.6, LT.	HOUSE NO. 9936
105+02.83, RT.	30.0, RT.	HOUSE NO. 9933
105+46.26, LT.	34.9, LT.	HOUSE NO. 9934
106+02.32, LT.	28.9, LT.	HOUSE NO. 9932
107+00.00, LT.	13.2, LT.	HOUSE NO. 9926

PIPE SCHEDULE FOR GRATE INLETS	
STA. 105+50, 19.7' RT. TO STA. 105+31, 19.1' RT.	6" HDPE 18 L.F.
STA. 104+74, 18.6' RT. TO STA. 105+26, 19.0' RT.	6" HDPE 52 L.F.

GRATE INLET SCHEDULE	
STA. 105+50, 19.7' RT. - SEE DETAIL ON DD-1	
STA. 104+74, 18.6' RT. - SEE DETAIL ON DD-1	

**GRINDING EXISTING ASPHALT PAVEMENT - 3 INCH DEPTH**  
1956 S.Y. - STA. 100+00 TO STA. 109+00, RT. & LT.

**GRINDING EXISTING ASPHALT PAVEMENT - 0 INCH TO 2 INCH DEPTH**  
250 S.Y. - STA. 299+73 TO STA. 300+74, RT. & LT.

**LEGEND**

[Pattern]	PROPOSED CARBIDE GRIND AND OVERLAY
[Pattern]	PROPOSED 1 1/2" HMA PAVEMENT RESURFACING
[Pattern]	PROPOSED BASE WIDENING HMA PAVEMENT OR HMA DRIVEWAY
[Pattern]	CONCRETE DRIVEWAY OR SIDEWALK RECONSTRUCTION

NOTE: SEE TYPICAL SECTIONS FOR DRIVEWAY SLOPES.

NOTE: SEE TYPICAL SECTIONS FOR DRIVEWAY SLOPES.

4 INCH CONCRETE SIDEWALK (STD. NO. R-3.05)	
FROM	TO
II S.F. - STA. 102+33.61, RT.	STA. 102+09, RT.
18 S.F. - STA. 101+07.47, LT.	STA. 102+81, RT.
9 S.F. - STA. 102+49.65, LT.	STA. 105+34, RT.
II S.F. - STA. 103+88.03, LT.	STA. 108+69, RT.

MOD. COMBINATION CURB AND GUTTER (STD. NO. R-3.01)			
FROM	TO	LENGTH (L.F.)	REMARKS
STA. 100+05, RT.	STA. 101+42, RT.	146	MEET EXISTING CURB AT 100+05
STA. 102+09, RT.	STA. 102+48, RT.	39	SPILL CUTTER; NOSE DOWN AT BOTH ENDS
STA. 102+81, RT.	STA. 105+22, RT.	243	NOSE DOWN AT 102+81
STA. 105+34, RT.	STA. 108+57, RT.	325	TRANSITION TO STD. CURB AT BOTH ENDS
STA. 108+69, RT.	STA. 108+75, RT.	7	MEET EXISTING CURB AT BOTH ENDS
STA. 100+17, LT.	STA. 108+98, LT.	896	MEET EXISTING CURB AT BOTH ENDS

STD. 7" COMBINATION CURB AND GUTTER (STD. NO. R-3.01)			
FROM	TO	LENGTH (L.F.)	REMARKS
STA. 101+42, RT.	STA. 101+69, RT.	29	TRANSITION FROM MODIFIED CURB FROM 101+42 TO 101+62.
STA. 105+22, RT.	STA. 105+34, RT.	12	PROPOSED CURB MEETS EXISTING AT STATION 101+69, RT.
STA. 108+57, RT.	STA. 108+69, RT.	12	

**NOTE:**  
CONTRACTOR SHALL REMOVE AND RESET MAILBOXES AND FENCES IMPACTED BY CURB CONSTRUCTION AND GRADING OPERATIONS AS DIRECTED BY THE COUNTY ENGINEER. COST SHALL BE INCIDENTAL TO THE CONTRACT LUMP SUM COST FOR CLEARING AND GRUBBING.

HOUSE DRAIN SCHEDULE		
HOUSE NO.	LOCATION	REMARKS
9217	STA. 101+23.8, 15.5' RT.	EXTEND 4" PVC AND OUTFALL THROUGH 7" CURB - 44 L.F.
9939	STA. 104+05, RT.	ADJUST 3" SUMP PUMP DRAIN TO ENSURE POSITIVE FLOW TO CURB LINE - 20 L.F.

**DEPARTMENT OF PUBLIC WORKS**  
HOWARD COUNTY, MARYLAND

*Steve Sharan* 3/10/08  
DIRECTOR OF PUBLIC WORKS

*Walter J. Hall* 3-10-08  
CHIEF, BUREAU OF HIGHWAYS

**JMT**  
JOHNSON, MIRMIRAN & THOMPSON  
Engineering A Brighter Future

72 Loveton Circle, Baltimore, Maryland 21152-0949

STATE OF MARYLAND  
Professional Engineer  
No. 15468  
Expiration Date 12/31/08

DES:	SAM	DATE:	MAR. 2008
DRN:	JMB	BY:	NO.
CHK:	PFC	DATE:	

**ROADWAY PLAN**  
**NAYLOR AVENUE & ROBINSON BOULEVARD**  
**- STORM DRAIN IMPROVEMENTS**

CAPITAL PROJECT No. D-1143

SCALE  
1" = 30'

SHEET  
5 OF 17



CURB GEOMETRY SCHEDULE					
POINT NO.	FROM LOCATION	POINT NO.	TO LOCATION	CURVE RADIUS	LENGTH
C13	206+38.85, 18.0' RT.	C14	206+66.77, 15.0' RT.	---	28.1'
C14	206+66.77, 15.0' RT.	C15	210+05.11, 15.0' RT.	---	338.3'
C18	207+01.60, 14.0' LT.	C19	207+36.05, 15.0' LT.	---	34.5'
C19	207+36.05, 15.0' LT.	C20	210+17.31, 15.0' LT.	---	281.3'
C20	210+17.31, 15.0' LT.	C21	210+31.86, 17.7' LT.	41'	14.9'

NOTES:  
 1. LOCATIONS AND LENGTHS ARE GIVEN ALONG MODIFIED COMBINATION CURB AND GUTTER AT FLOW LINE.  
 2. SEE STD. DETAIL R-3.06 FOR TRANSITION TO STD. 7" COMBINATION CURB AND GUTTER AT TYPE 'A-5' INLETS.

**TREE NOTE:**  
 ALL TREES AND SHRUBS WITHIN THE LOD ARE TO REMAIN IN PLACE AND UNHARMED; UNLESS OTHERWISE DIRECTED BY THE COUNTY ENGINEER.

BOTTOM CUTOFF WALL SCHEDULE			
LOCATION	RIPRAP CLASS	LENGTH (FT)	
HW-1	II	10	

\*DIMENSIONS OF CUTOFF WALL AS SHOWN ON PIPE PROFILE.

4 INCH CONCRETE SIDEWALK (STD. NO. R-3.05)	
25 S.F.	- STA. 308+19, LT.

\* REPLACE EXISTING SIDEWALK DISTURBED BY STORM DRAIN CONSTRUCTION.

DRAINAGE STRUCTURE SCHEDULE					
NO.	STATION	OFFSET	TYPE	SD NO.	DEPTH
I-11	206+42.0	17.7', RT.	TYPE S COMB. INLET	SD 4.32	2.94'
I-12	209+00.0	15.0', RT.	TYPE S COMB. INLET	SD 4.32	4.50'
I-16	209+00.0	15.0', LT.	TYPE S COMB. INLET	SD 4.32	7.51'
M-5	302+03.0	5.7', LT.	48" DIA. STANDARD PRECAST MANHOLE	G 5J2	6.70'
M-6	304+17.0	4.1', LT.	48" DIA. STANDARD PRECAST MANHOLE	G 5J2	10.15'
M-7	304+41.0	3.9', RT.	48" DIA. STANDARD PRECAST MANHOLE	G 5J2	10.12'
M-8	306+44.0	4.6', RT.	48" DIA. STANDARD PRECAST MANHOLE	G 5J2	6.92'
M-9	308+16.0	10.7', RT.	48" DIA. STANDARD PRECAST MANHOLE	G 5J2	4.77'
M-10	308+22.0	29.7', LT.	48" DIA. STANDARD PRECAST MANHOLE	G 5J2	11.63'
HW-1	308+52.1	53.9', LT.	TYPE A HEADWALL FOR 24" RCP	SD 5.11	---

GRINDING EXISTING ASPHALT PAVEMENT - 0 INCH TO 2 INCH DEPTH  
 1657 S.Y. - STA. 300+74 TO STA. 308+25, LT. & RT.

7 INCH PORTLAND CEMENT CONCRETE PAVEMENT FOR DRIVEWAY, MIX 6 (STD. NO. R-6.03)			
QUANTITY (S.Y.)	LOCATION	OFFSET TIE-IN	COMMENTS
16	206+46.73, LT.	26.5, LT.	HOUSE NO. 9820
19	208+72.22, RT.	24.7, RT.	HOUSE NO. 9801

NOTE: SEE TYPICAL SECTIONS FOR DRIVEWAY SLOPES.

BASELINE CONTROL COORDINATES			
LOCATION	STATION	EASTING	NORTHING
BASLINE OF ROBINSON BLVD.	POT STA. 210+43.62	1,353,798.04	528,578.23

ASPHALT PAVEMENT FOR DRIVEWAY (STD. NO. R-2.01 [SECTION P-1])		
LOCATION	OFFSET TIE-IN	COMMENTS
206+74.28, RT.	26.2, RT.	HOUSE NO. 9819
207+25.35, LT.	28.0, LT.	HOUSE NO. 9816
207+30.84, RT.	25.3, RT.	HOUSE NO. 9815
207+45.56, LT.	27.6, LT.	HOUSE NO. 9812
207+75.43, RT.	25.1, RT.	HOUSE NO. 9811
208+25.85, LT.	25.3, LT.	HOUSE NO. 9808
208+43.89, LT.	31.6, LT.	HOUSE NO. 9804
209+98.26, LT.	31.7, LT.	HOUSE NO. 9800

NOTE: SEE TYPICAL SECTIONS FOR DRIVEWAY SLOPES

PIPE SCHEDULE			
FROM	TO	TYPE	LENGTH
I-12	I-16	15" RCP, CL IV	27 L.F.
M-6	M-6	18" RCP, CL IV	143 L.F.
M-5	M-6	18" RCP, CL IV	210 L.F.
M-6	M-7	24" RCP, CL IV	22 L.F.
M-7	M-8	24" RCP, CL IV	199 L.F.
M-8	M-9	24" RCP, CL IV	168 L.F.
M-9	M-10	24" RCP, CL IV	37 L.F.
M-10	HW-1	24" RCP, CL IV	37 L.F.

ADJUST EXISTING UTILITIES			
LOCATION	UTILITY TYPE	EXIST. ELEV.	PROP. ELEV.
I EA. - STA. 206+45.9, 6.5' LT.	SAN. SEWER MANHOLE	238.41	238.54
I EA. - STA. 208+90.7, 19.7' RT.	WATER VALVE	240.03	240.14

HOUSE DRAIN SCHEDULE			REMARKS
HOUSE NO.	LOCATION		
9819	STA. 206+39, 19.1' RT.		EXTEND 4" PLASTIC PIPE AND TIE INTO INLET I-11 - 2 L.F.
9815	STA. 206+93, 17.6' RT.		STA. 207+39, 17.4' RT.
9815	STA. 207+39, 17.4' RT.		EXTEND 4" PVC AND TIE INTO INLET I-11 - 100 L.F.
9815	STA. 207+42, 17.3' RT.		EXTEND 4" HDPE AND TIE INTO INLET I-11 - 100 L.F.

STD. 7" COMBINATION CURB AND GUTTER (STD. NO. R-3.01)			
FROM	TO	LENGTH (L.F.)	REMARKS
STA. 308+16.8, LT.	STA. 308+21.8, LT.	5 L.F.	REPLACE EX. CURB AND GUTTER DISTURBED BY STORM DRAIN CONSTRUCTION

RIPRAP OUTLET PROTECTION SCHEDULE				
LOCATION	RIPRAP CLASS	LENGTH (FT)	WIDTH (FT)	QUANTITY (S.Y.)
HW-1	II	12.5	10	12.6

NOTE:  
 CONTRACTOR SHALL REMOVE AND RESET ANY MAILBOXES AND SIGNS AND FENCES IMPACTED BY CURB CONSTRUCTION AND GRADING OPERATIONS AS DIRECTED BY THE COUNTY ENGINEER. COST SHALL BE INCIDENTAL TO THE CONTRACT LUMP SUM COST FOR CLEARING AND GRUBBING.

SURVEY CONTROL POINTS			
NO.	EASTING	NORTHING	ELEV. DESC.
JMT-500	1,353,829.0892	528,426.1731	238.15 R&C
JMT-501	1,353,988.2952	528,590.7641	223.00 X-CUT

JMT-501

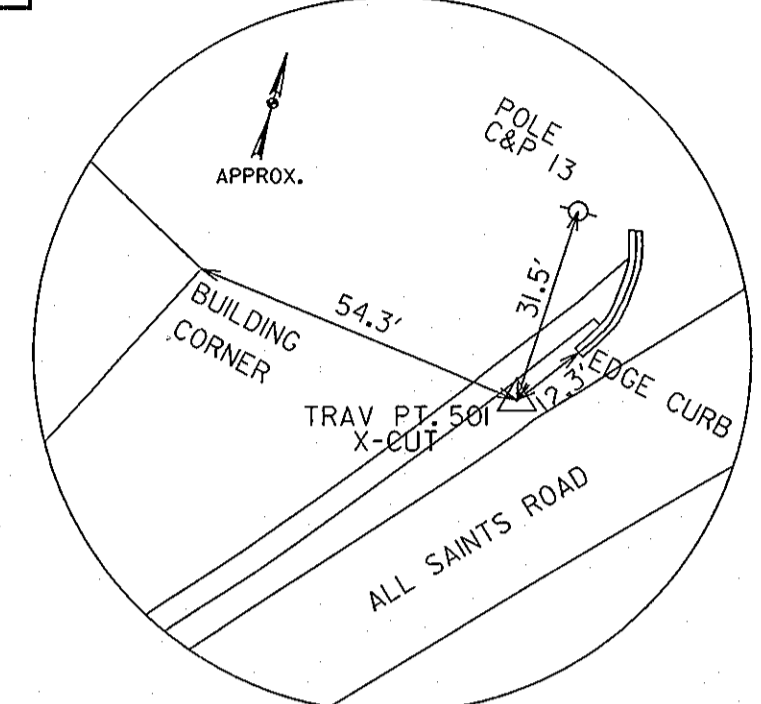

SURVEY CONTROL POINT NOT TO SCALE

JMT-500

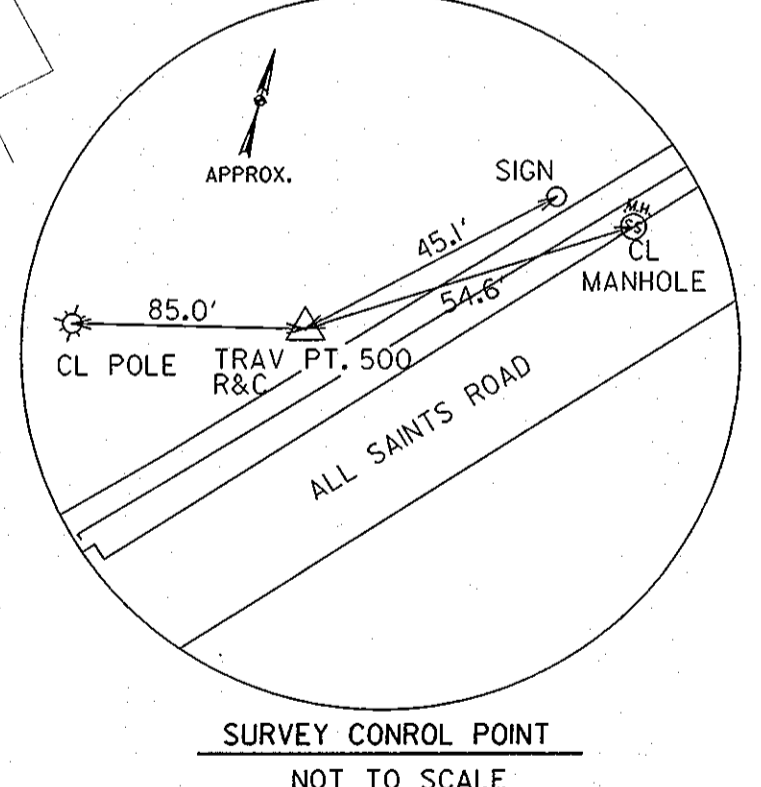

SURVEY CONTROL POINT NOT TO SCALE

UTILITY TEST PIT SCHEDULE			
NO.	LOCATION	UTILITY	DEPTH
TP 3-1	STA. 206+41, 13.5 RT.	6" WATER	4.20'
TP 3-2	STA. 206+41, 21.3 RT.	2" GAS	4.11'
TP 3-3	STA. 208+45, 19.1 LT.	12" WATER	4.74'
TP 3-4	STA. 208+45, 12.8 RT.	6" WATER	4.44'
TP 3-5	STA. 208+45, 19.6 RT.	2" GAS	3.92'
TP 3-6	STA. 301+15, 7.3 LT.	2-3/4" AND 1-1/4" ELEC.	1.88'
TP 3-7	STA. 301+44, 5.3 LT.	4" GAS	2.90'
TP 3-8	STA. 301+64, 5.8 LT.	2-1/2" ELEC.	3.23'
TP 3-9	STA. 301+80, 5.7 LT.	1/2" WATER	3.32'
TP 3-10	STA. 302+33, 5.3 LT.	1/2" WATER	3.60'
TP 3-11	STA. 302+89, 5.0 LT.	1/2" WATER	4.30'
TP 3-12	STA. 303+78, 3.8 LT.	6" WATER	5.23'
TP 3-13	STA. 210+25, 14.8 LT.	6" ELEC.	3.12'
TP 3-14	STA. 304+22, 0.8 LT.	12" WATER	5.01'
TP 3-15	STA. 305+41, 1.5 RT.	1/2" ELEC.	4.52'
TP 3-16	STA. 305+41, 4.4 RT.	3/4" ELEC.	4.50'
TP 3-17	STA. 306+69, 9.5 RT.	3/4" WATER	4.66'
TP 3-18	STA. 308+11, 10.4 RT.	8" WATER	8.25'
TP 3-19	STA. 308+21, 13.5 RT.	16" WATER	8.16'
TP 3-20	E 1,354,164.2585 N 528,761.6469	ELEC.	NOT FOUND
TP 3-21	E 1,354,167.38 N 528,743.10	16" WATER	5.52'
TP 3-25	STA. 206+99, 17.9 LT.	1/2" GAS	2.70
TP 3-26	STA. 209+44, 22.6 LT.	1/4" GAS	3.54'
TP 2-21	STA. 206+75, 12.4' LT.	3/8" GAS	2.57'
TP 2-22	STA. 207+00, 11.7' LT.	3/4" GAS	2.61'
TP 2-23	STA. 207+76, 13.1' LT.	3/4" GAS	3.07'
TP 2-24	STA. 207+98, 13.7' LT.	3/4" GAS	3.17'
TP 2-25	STA. 208+74, 13.3' LT.	1/2" GAS	3.30'
TP 2-26	STA. 209+43, 14.1' LT.	3/8" GAS	2.47'
TP 2-27	STA. 308+15, 2.7' LT.	3" GAS	7.19'
TP 2-28	STA. 308+18, 28.3' LT.	6" ELEC.	5.25'

LEGEND	
[Symbol]	PROPOSED CARBIDE GRIND AND OVERLAY
[Symbol]	PROPOSED 1 1/2" HMA PAVEMENT RESURFACING
[Symbol]	PROPOSED BASE WIDENING HMA PAVEMENT OR HMA DRIVEWAY
[Symbol]	CONCRETE DRIVEWAY OR SIDEWALK RECONSTRUCTION

DEPARTMENT OF PUBLIC WORKS  
 HOWARD COUNTY, MARYLAND  
 Director of Public Works: Steve Sharav  
 Chief, Bureau of Engineering: [Signature]  
 Chief, Bureau of Highways: [Signature]

JMT  
 JOHNSON, MIRMIRAN & THOMPSON  
 Engineering A Brighter Future  
 72 Lovett Circle, Baltimore, Maryland 21152-0949  
 State of Maryland Professional Engineer Seal  
 Date: MAR. 2008

DES: SAM			
DRN: JMB			
CHK: PFC			
DATE: MAR. 2008	BY	NO.	DATE

ROADWAY PLAN  
 NAYLOR AVENUE & ROBINSON BOULEVARD  
 - STORM DRAIN IMPROVEMENTS  
 CAPITAL PROJECT No. D-1143  
 SCALE: 1" = 30'  
 SHEET: 7 OF 17

FILE: S:\proj\300683\_2\proj\w\cadd\p520\dwg\108.dwg  
 DATE: 3/7/2008

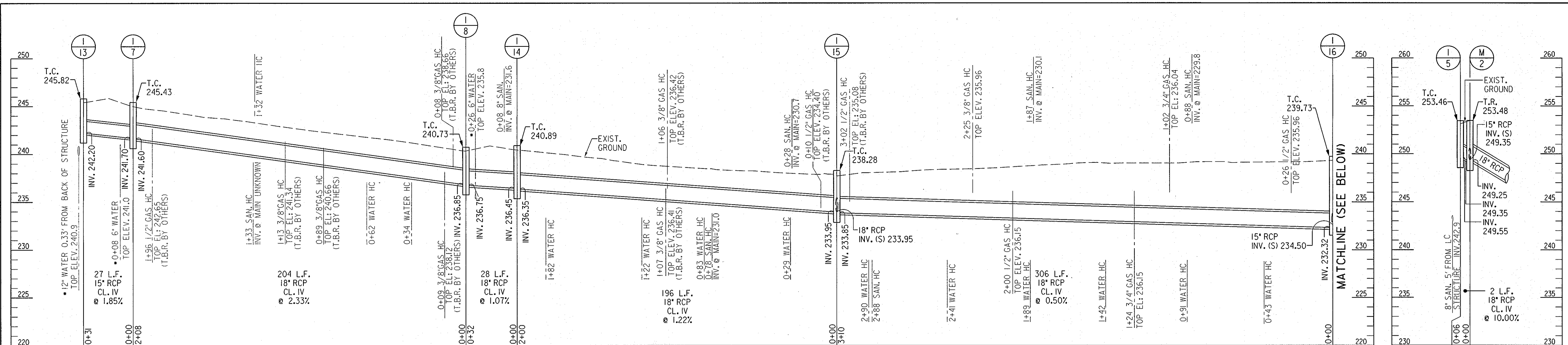

STA. 201+81, LT. TO STA. 208+47, LT. - ROBINSON BOULEVARD

STA. 105+57, LT. - NAYLOR AVENUE

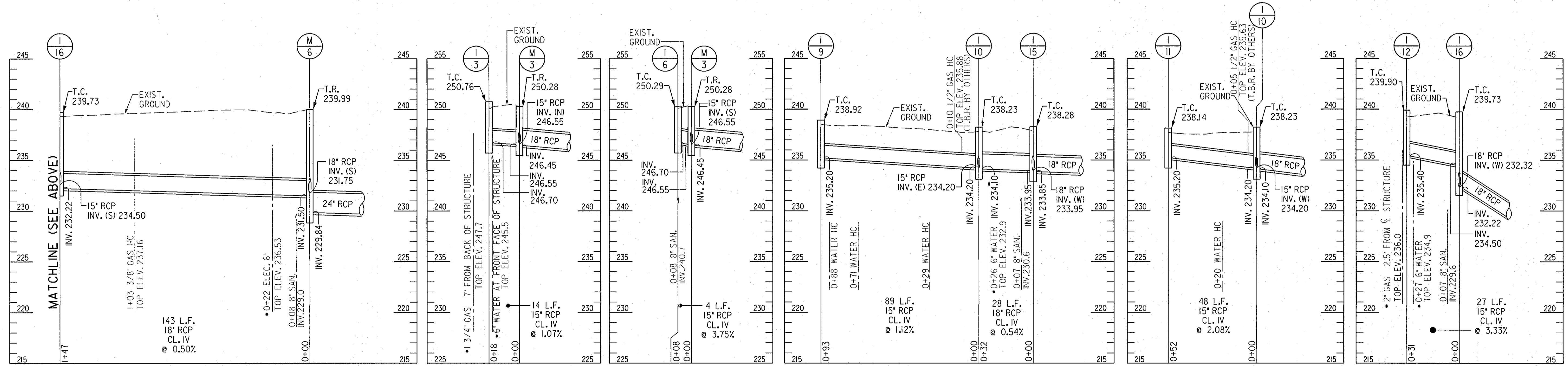

STA. 208+47, LT. - ROBINSON BOULEVARD TO STA. 304+17, LT. - ALL SAINTS ROAD

STA. 108+61, RT. TO STA. 108+62, LT. - NAYLOR AVENUE  
 STA. 108+61, LT. TO STA. 108+62, LT. - NAYLOR AVENUE

STA. 208+97, RT. TO STA. 205+90, LT. - ROBINSON BOULEVARD

STA. 206+42, RT. TO STA. 205+90, RT. - ROBINSON BOULEVARD

STA. 208+47, RT. TO STA. 208+47, LT. - ROBINSON BOULEVARD

NOTE: UTILITY TOP ELEVATIONS AND LOCATIONS ARE BASED ON TEST HOLE REPORTS PREPARED BY KCI TECHNOLOGIES. EXACT LOCATION AND EXISTING GROUND ELEVATIONS AT TEST HOLES HAVE NOT BEEN SURVEYED.

FILE: g:\m\10063\_2\env\pwr\_vw\cad\pp\pp\main\106.dwg DATE: 3/7/2008 8:59 AM

DEPARTMENT OF PUBLIC WORKS  
 HOWARD COUNTY, MARYLAND

*Steve Slaver* 3/10/08  
 DIRECTOR OF PUBLIC WORKS

*Walter Z. ...* 3-10-08  
 CHIEF, BUREAU OF HIGHWAYS

PROJECTS DIVISION

**JMT**  
 JOHNSON, MIRMIRAN & THOMPSON  
 Engineering, A Brighter Future  
 72 Loveton Circle, Baltimore, Maryland 21152-0949

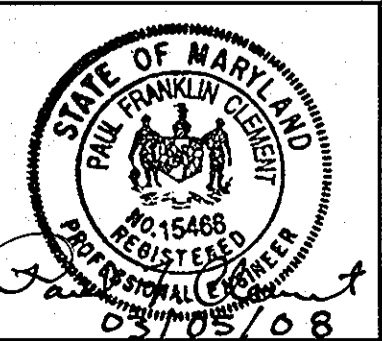

DES:	SAM		
DRN:	JMB		
CHK:	PFC		
DATE:	MAR. 2008	BY	NO.

STORM DRAIN PROFILES  
**NAYLOR AVENUE & ROBINSON BOULEVARD**  
 - STORM DRAIN IMPROVEMENTS

CAPITAL PROJECT No. D-1143



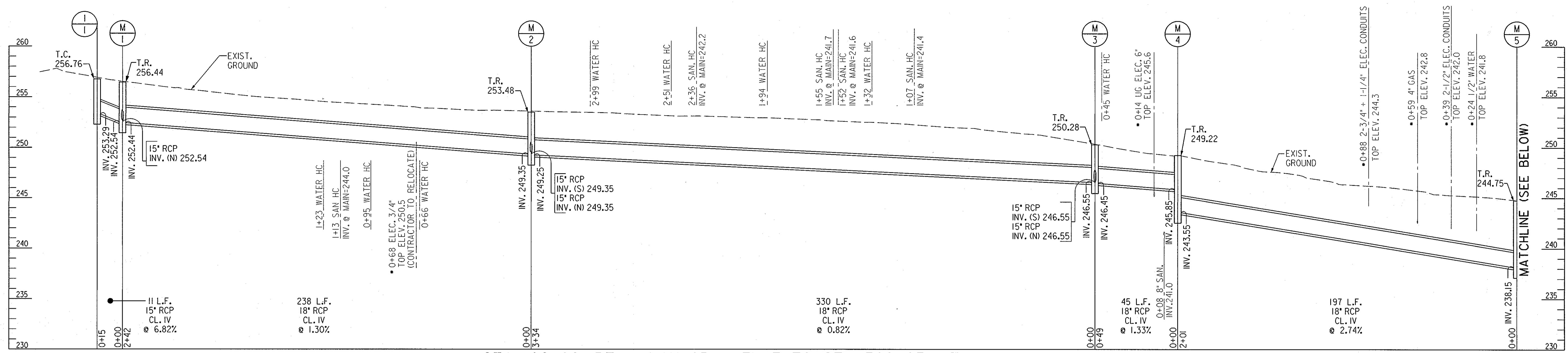

STA. 102+86, RT. - NAYLOR AVENUE TO STA. 302+03, LT. - ALL SAINTS ROAD

NOTE: UTILITY TOP ELEVATIONS AND LOCATIONS ARE BASED ON TEST HOLE REPORTS PREPARED BY KCI TECHNOLOGIES. EXACT LOCATION AND EXISTING GROUND ELEVATIONS AT TEST HOLES HAVE NOT BEEN SURVEYED.

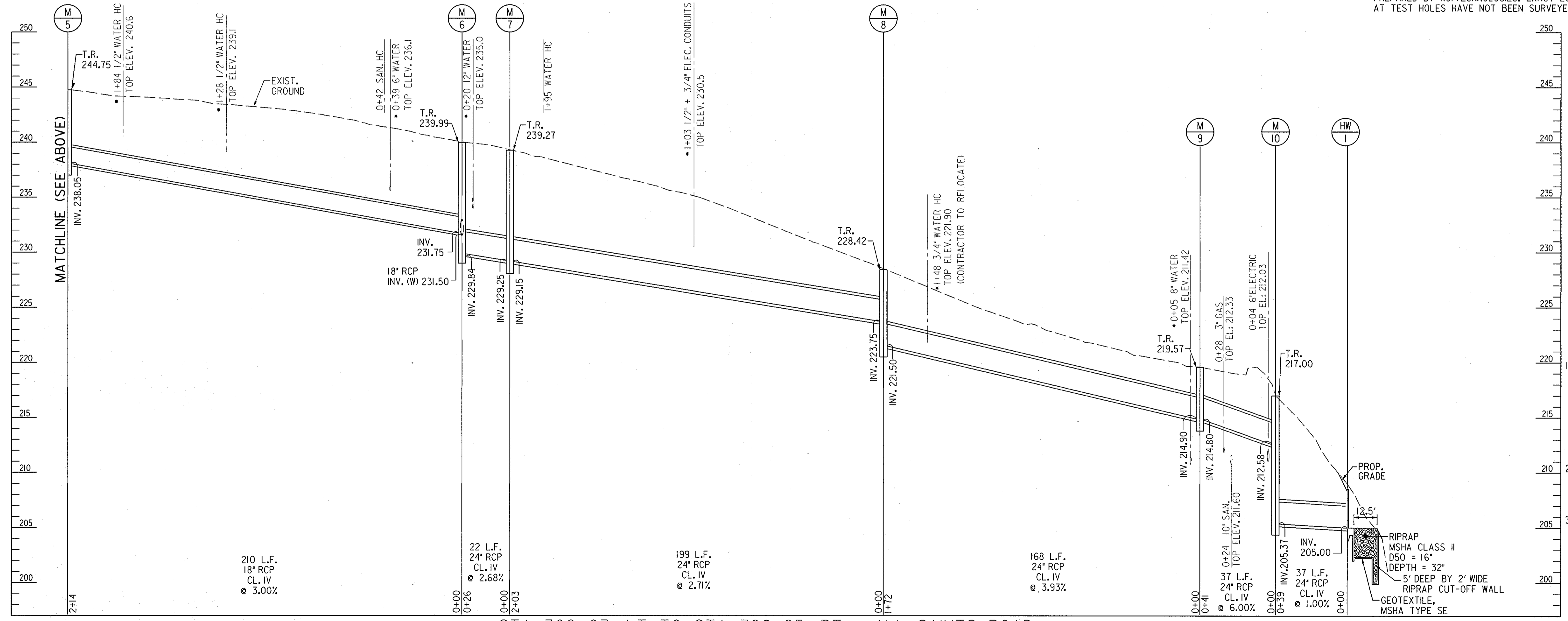

STA. 302+03, LT. TO STA. 308+25, RT. - ALL SAINTS ROAD

- GENERAL PIPE PROFILE NOTES (PP-1 TO PP-3):
1. WATER HOUSE CONNECTIONS (HC) REQUIRED TO BE RELOCATED HAVE BEEN IDENTIFIED FOR ONLY THOSE UTILITIES FOR WHICH TEST PIT INFORMATION HAS BEEN PROVIDED. CONTRACTOR SHALL TEST PIT REMAINING WATER HOUSE CONNECTION CROSSINGS PER THE CONTRACT DOCUMENTS TO DETERMINE ADDITIONAL RELOCATIONS THAT WILL BE NECESSARY.
  2. WHERE NOTED, ELEVATIONS GIVEN AT SANITARY HOUSE CONNECTIONS REFERENCE ELEVATION OF SANITARY 8" MAIN AT LOCATION OF CONNECTION.
  3. CONTRACTOR SHALL COORDINATE W/BGE TO ENSURE THAT RELOCATION OF GAS HOUSE CONNECTIONS LABELED AS TO BE RELOCATED (T.B.R.) BY OTHERS HAVE BEEN COMPLETED PRIOR TO COMMENCING STORM DRAIN WORK.

FILE: 915001200851.dwg  
DATE: 3/10/08

DEPARTMENT OF PUBLIC WORKS  
HOWARD COUNTY, MARYLAND

*Steve Shanor* 3/10/08  
DIRECTOR OF PUBLIC WORKS

*Robert Segan* 3/10/08  
CHIEF, BUREAU OF ENGINEERING

*William J. Hall* 3-10-08  
CHIEF, BUREAU OF HIGHWAYS

PROJECTS DIVISION

**JMT**  
JOHNSON, MIRMIRAN & THOMPSON  
Engineering A Brighter Future  
72 Loveton Circle, Baltimore, Maryland 21152-0949

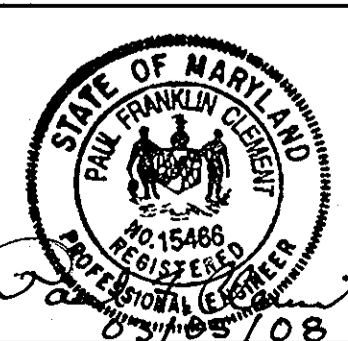

DES:	SAM				
DRN:	JMB				
CHK:	PFC				
DATE:	MAR. 2008	BY	NO.		DATE

STORM DRAIN PROFILES  
NAYLOR AVENUE & ROBINSON BOULEVARD  
- STORM DRAIN IMPROVEMENTS

CAPITAL PROJECT No. D-1143

PP-1  
SCALE  
HOR. 1"=30'  
VERT. 1"=5'  
SHEET  
8 OF 17

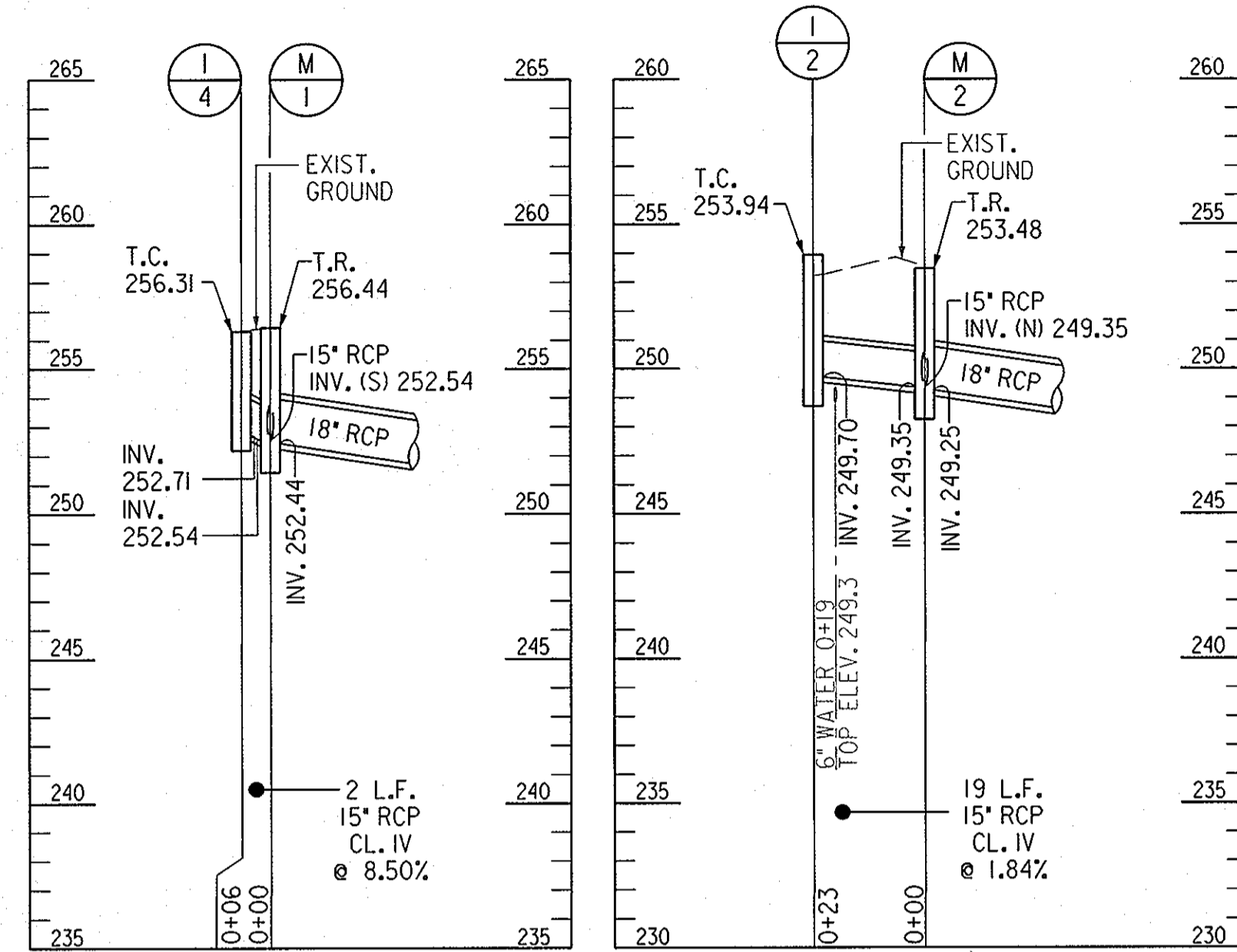

STA. 102+86, LT. TO  
- NAYLOR AVENUE

STA. 105+57, RT. TO  
STA. 105+57, LT.  
- NAYLOR AVENUE

**PIPE PROFILE**

SCALE:  
HOR. 1"=30'  
VERT. 1"=5'

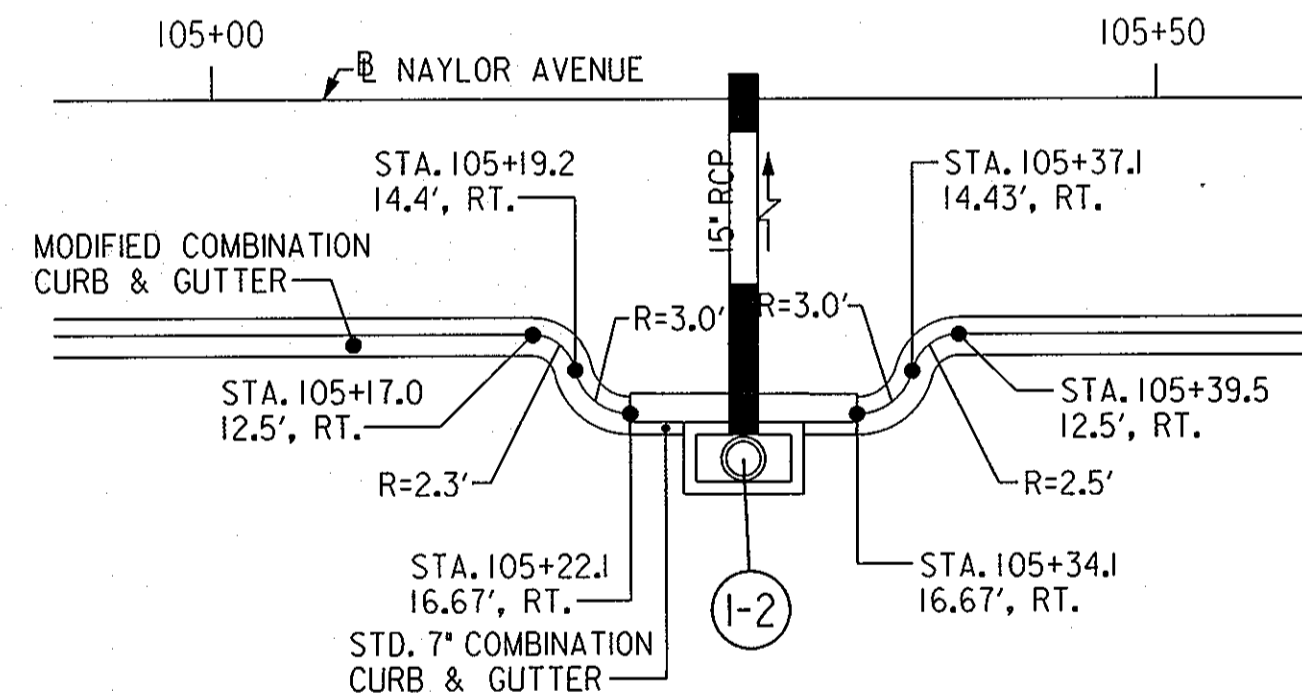

NOTE: DIMENSIONS GIVEN ALONG FLOW LINE.

**SPECIAL CURB LAYOUT  
AT INLET, I-2**

SCALE: 1"=10'

DIP		
PIPE DIA. (")	"V"	TRENCH PAYMENT WIDTH
4	12	28
6	11	28
8	10	28
10	9	28
12	8	28
14	8	30
16	8	32
18	8	34
20	8	36
24	12	48

RCP		
PIPE DIA. (")	"V"	TRENCH PAYMENT WIDTH
4	12	28
6	11	28
8	10	28
10	9	28
12	8	28
15	8	31
18	8	34
21	8	37
24	12	48
27	12	51
30	12	54
33	15	63
36	15	66
42	15	72
48	18	84
54	18	90
60	18	96
66	18	102
72	18	108
78	18	114
84	18	120
90	18	126
96	18	132
102	18	138
108	18	144

NOTES:

1. THE "V" DIMENSION SHALL BE USED TO CALCULATE MAXIMUM TRENCH PAY WIDTH.
2. FOR TRENCHES WHERE TRENCH BOX OR TRENCH SHEETING IS NOT REQUIRED, MEASUREMENT FOR CONTINGENT BORROW MATERIALS WILL BE BASED ON THE TRENCH WIDTH SHOWN.
3. FOR TRENCHES WHERE TRENCH BOX OR TRENCH SHEETING IS REQUIRED, MEASUREMENT FOR CONTINGENT BORROW MATERIALS WILL BE BASED ON THE TRENCH WIDTH SHOWN PLUS 24 INCHES.
4. THE MAXIMUM WIDTH OF THE TRENCH EXCAVATED ON-SITE FOR RCP, SHALL NOT EXCEED THE TRENCH PAYMENT WIDTH PLUS 12 INCHES.
5. MINIMUM SPACING BETWEEN PARALLEL CULVERT PIPES SHALL BE TWICE THE "V" DIMENSION.
6. SPECIAL DESIGN IS REQUIRED AND SHALL BE SPECIFIED OR DETAILED IN THE CONTRACT DOCUMENTS FOR THE FOLLOWING PIPES:  
RCP STORM DRAINS LARGER THAN 108 INCHES  
RCP GRANTY SANITARY SEWERS LARGER THAN 48 INCHES  
DIP LARGER THAN 24 INCHES  
STREAM CROSSINGS SEE S-3.11 AND S-3.12

ALL DIMENSIONS IN INCHES

Howard County, Maryland Department of Public Works	Pipe Trench DIP & RCP	Detail G-2.11
---	--------------------------	------------------

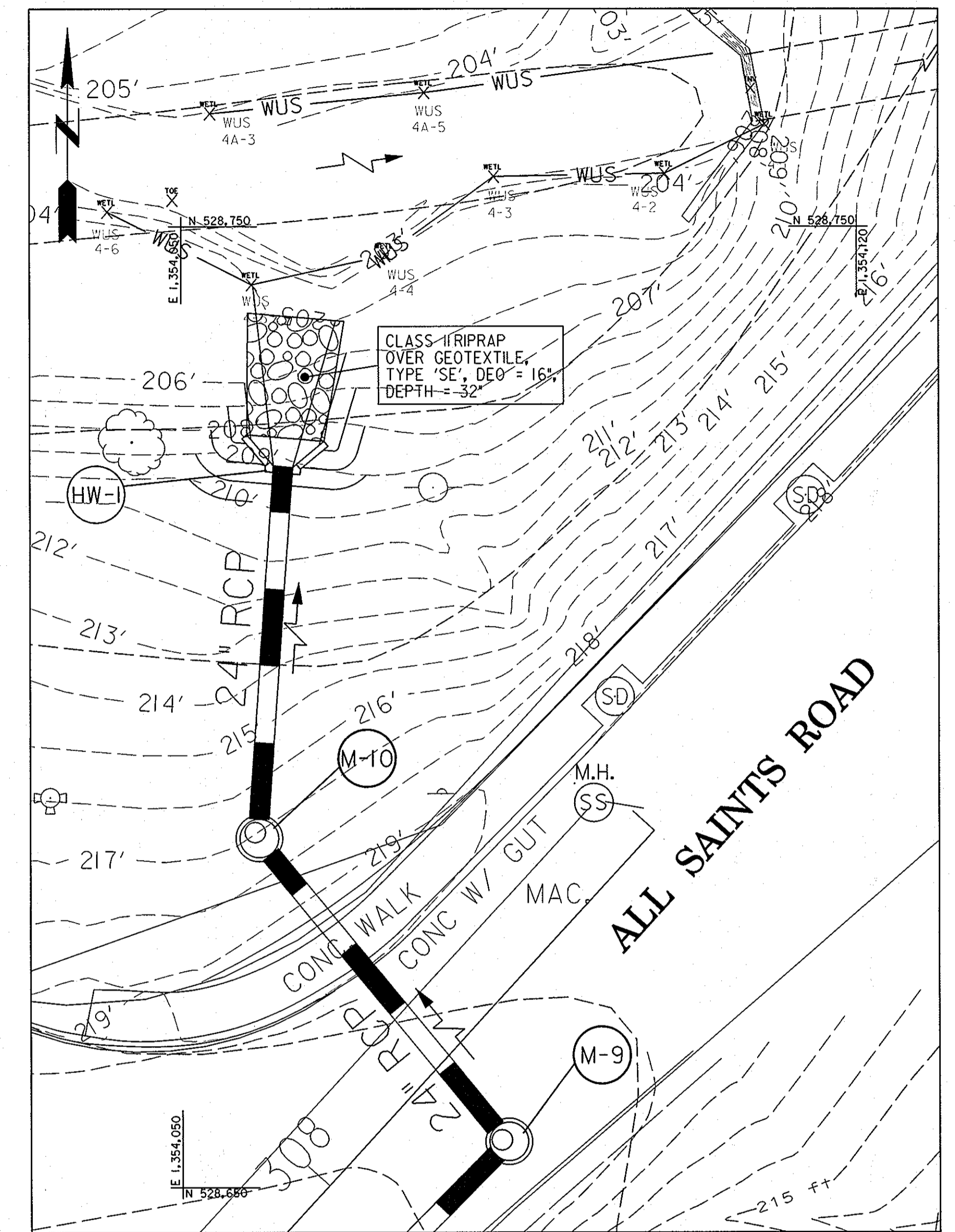

**GRADING PLAN**

HW-1

SCALE: 1"=10'

NOTE: UTILITY TOP ELEVATIONS AND LOCATIONS ARE BASED ON TEST HOLE REPORTS PREPARED BY KCI TECHNOLOGIES. EXACT LOCATION AND EXISTING GROUND ELEVATIONS AT TEST HOLES HAVE NOT BEEN SURVEYED.

FILE: G:\SMD\300662\_28\proj\01 - HW-1\DWG\PP3.DWG DATE: 3/5/2008 2:56:08 PM

DEPARTMENT OF PUBLIC WORKS  
HOWARD COUNTY, MARYLAND

*Steve Shanan* 3/10/08  
DIRECTOR OF PUBLIC WORKS

*Walter D. Wall* 3-10-08  
CHIEF, BUREAU OF HIGHWAYS

**JMT**  
JOHNSON, MIRMIRAN & THOMPSON  
Engineering A Brighter Future  
72 Lovston Circle, Baltimore, Maryland 21152-0949

STATE OF MARYLAND  
PUBLIC WORKS  
APPROVED  
03/10/08

DES:	SAM				
DRN:	JMB				
CHK:	PFC				
DATE:	MAR. 2008	BY	NO.		DATE

STORM DRAIN PROFILES  
NAYLOR AVENUE & ROBINSON BOULEVARD  
- STORM DRAIN IMPROVEMENTS  
CAPITAL PROJECT No. D-1143

PP-3  
SCALE  
AS SHOWN  
SHEET  
10 OF 17

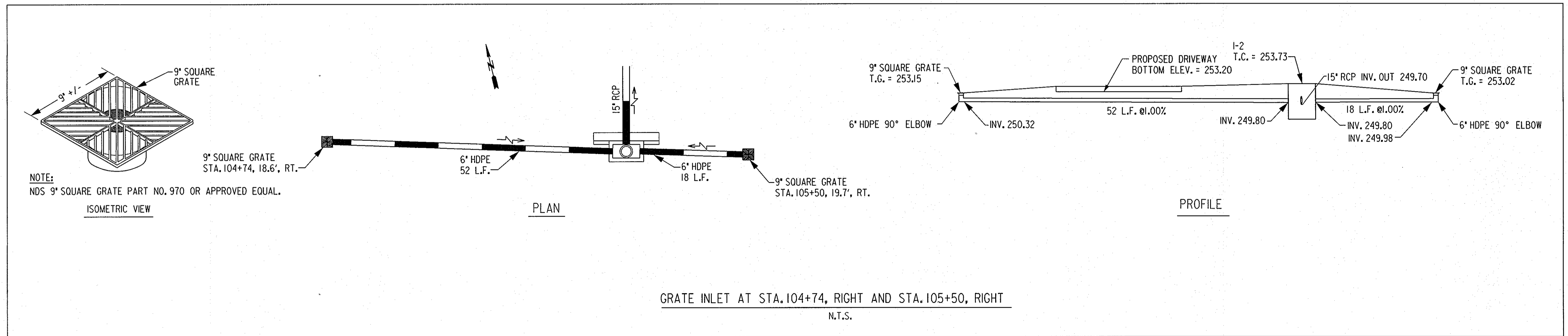
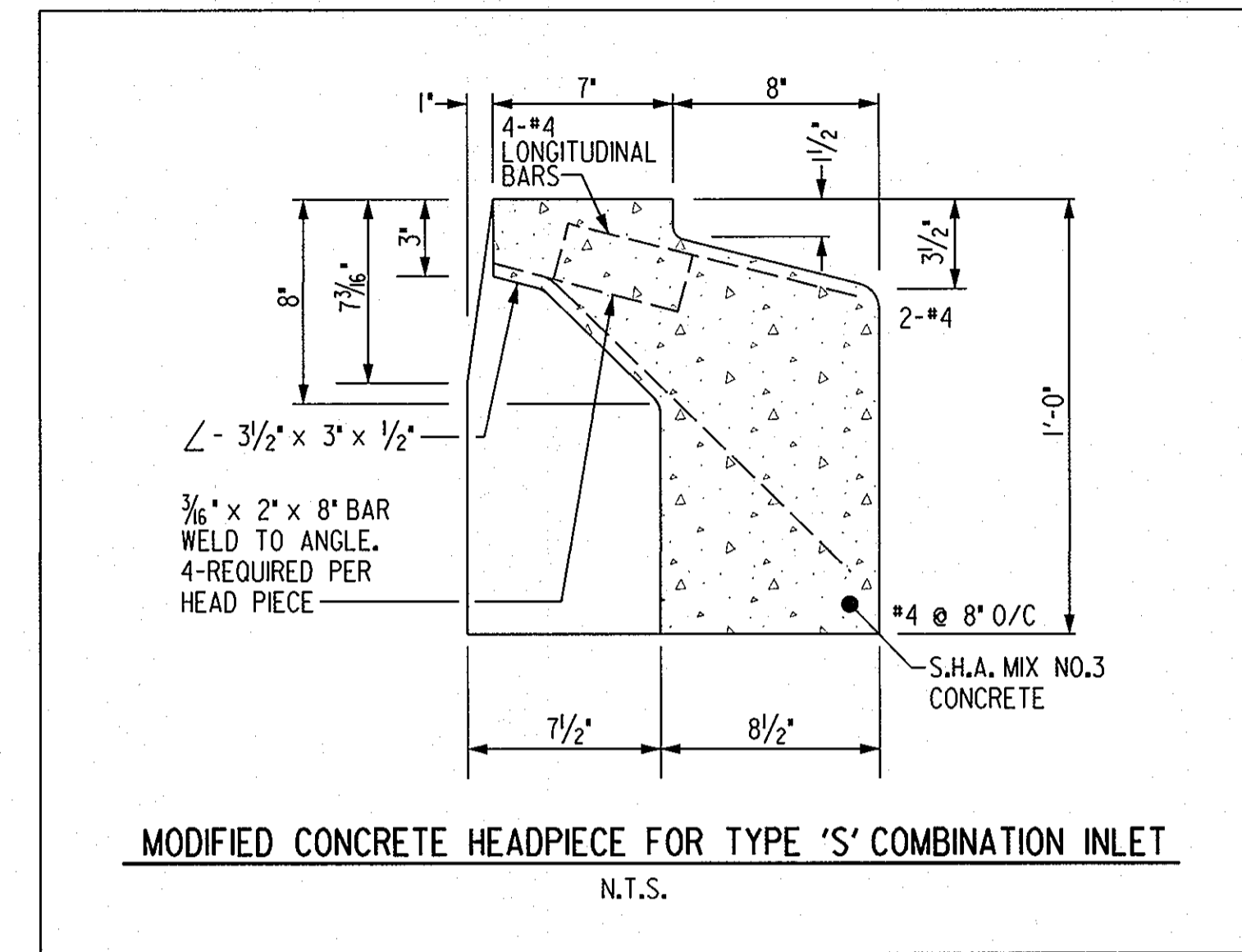
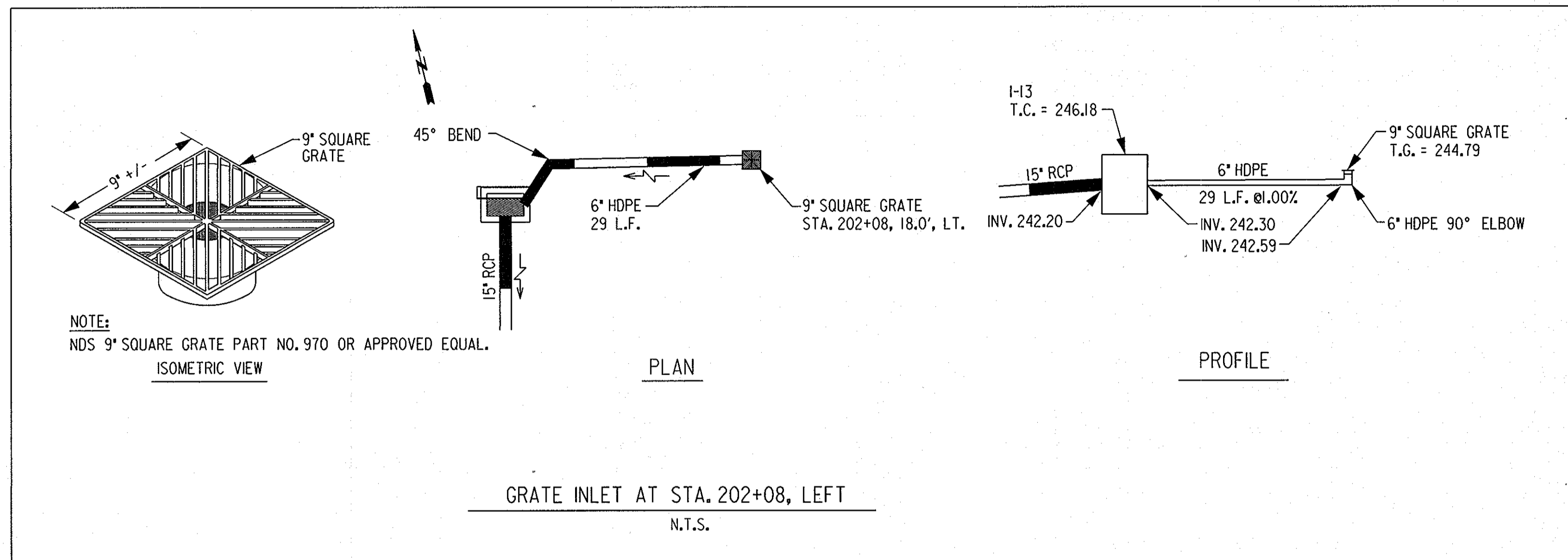

GENERAL NOTE:  
ALL FITTINGS (ELBOWS AND BENDS) SHALL BE INCIDENTAL TO THE COST OF THE 6" HDPE PIPE.

FILE: S:\Users\300683\_26\my\p\w\cad\add\NAYLOR\_0308.dgn  
DATE: 3/7/2008 8:55:08 AM

DEPARTMENT OF PUBLIC WORKS  
HOWARD COUNTY, MARYLAND

*Steve Shaner* 3/10/08  
DIRECTOR OF PUBLIC WORKS

*Will R. Abell* 3-10-07  
CHIEF, BUREAU OF HIGHWAYS

**JMT**  
JOHNSON, MIRMIRAN & THOMPSON  
Engineering A Better Future  
72 Loveton Circle, Baltimore, Maryland 21152-0949



DES:					
DRN:					
CHK:					
DATE:	BY	NO.			DATE

DRAINAGE DETAILS  
NAYLOR AVENUE & ROBINSON BOULEVARD  
- STORM DRAIN IMPROVEMENTS  
CAPITAL PROJECT No. D-II43

DD-1  
SCALE AS SHOWN  
SHEET 11 OF 17

**STANDARD SEDIMENT CONTROL NOTES**

- A minimum of 48 hours notice must be given to the Howard County Department of Inspections, Licenses and Permits, Sediment Control Division prior to the start of any construction (410) 313-1855.
- All vegetative and structural practices are to be installed according to the provisions of this plan and are to be in conformance with the most current MARYLAND STANDARDS AND SPECIFICATIONS FOR SOIL EROSION AND SEDIMENT CONTROL and revisions thereto.
- Following initial soil disturbance or re-disturbance, permanent or temporary stabilization shall be completed within a 7 calendar days for all perimeter sediment control structures, dikes, perimeter slopes and all slopes greater than 3:1, b) 14 days as to all other disturbed or graded areas on the project site.
- All sediment traps/basins shown must be fenced and warning signs posted around their perimeter in accordance with Vol. I, Chapter 12 of the HOWARD COUNTY DESIGN MANUAL, Storm Drainage.
- All disturbed areas must be stabilized within the time period specified above in accordance with the 1994 MARYLAND STANDARDS AND SPECIFICATIONS FOR SOIL EROSION AND SEDIMENT CONTROL for permanent seeding (Sec. 51), sod (Sec. 54), temporary seeding (Sec. 50) and mulching (Sec. 52). Temporary stabilization with mulch alone can only be done when recommended seeding dates do not allow for proper germination and establishment of grasses.
- All sediment control structures are to remain in place and are to be maintained in operative condition until permission for their removal has been obtained from the Howard County Sediment Control Inspector.
- Site Analysis: (NOT FOR BIDDING PURPOSES)
 

Total Area of Site	4.66 Acres
Area Disturbed	2.36 Acres
Area to be roofed or paved	1.77 Acres
Area to be vegetatively stabilized	0.59 Acres
Total Cut	0 Cu. Yds.
Total Fill	328 Cu. Yds.
Off-site waste/borrow area locations:	UNKNOWN
- Any sediment control practice which is disturbed by grading activity for placement of utilities must be repaired on the same day of disturbance.
- Additional sediment control must be provided, if deemed necessary by the Howard County Sediment Control Inspector.
- On all sites with disturbed areas in excess of 2 acres, approval of the inspection agency shall be requested upon completion of installation of perimeter erosion and sediment controls, but before proceeding with any other earth disturbance or grading. Other building or grading inspection approvals may not be authorized until this initial approval by the inspection agency is made.
- Trenches for the construction of utilities is limited to three pipe lengths or that which shall be back-filled and stabilized by the end of each work day, whichever is shorter.

**PERMANENT SEEDING NOTES**

Apply to graded or cleared areas not subject to immediate further disturbance where a permanent long-lived vegetative cover is needed.

Seedbed Preparation: Loosen upper three inches of soil by raking, disking or other acceptable means before seeding, if not previously loosened.

Soil Amendments: In lieu of soil test recommendations, use one of the following schedules:

- Preferred -- Apply 2 tons/acre dolomitic limestone (92 lbs/1000 sq. ft.) and 600 lbs/acre 10-10-10 fertilizer (14 lbs/1000 sq. ft.) before seeding. Harrow or disk into upper three inches of soil. At time of seeding, apply 400 lbs/acre 30-0-0 ureaform fertilizer (9 lbs/1000 sq. ft.).
- Acceptable -- Apply 2 tons/acre dolomitic limestone (92 lbs/1000 sq. ft.) and 1000 lbs/acre 10-10-10 fertilizer (23 lbs/1000 sq. ft.) before seeding. Harrow or disk into upper three inches of soil.

Seeding -- For the period March 1 -- April 30, and August 1 -- October 15, seed with 60 lbs/acre (1.4 lbs/1000 sq. ft.) of Kentucky 31 Tall Fescue. For the period May 1 -- July 31, seed with 60 lbs Kentucky 31 Tall Fescue per acre and 2 lbs/acre (.05 lbs/1000 sq. ft.) of weeping lovegrass. During the period of October 16 -- February 28, protect site by:  
 Option 1 -- Two tons per acre of well anchored straw mulch and seed as soon as possible in the spring.  
 Option 2 -- Use sod.  
 Option 3 -- Seed with 60 lbs/acre Kentucky 30 Tall Fescue and mulch with 2 tons/acre well anchored straw.

Mulching -- Apply 1-1/2 to 2 tons per acre (70 to 90 lbs/1000 sq. ft.) of unrotted small grain straw immediately after seeding. Anchor mulch immediately after application using mulch anchoring tool or 218 gallons per acre (5 gal/1000 sq. ft.) of emulsified asphalt on flat areas. On slopes 8 feet or higher, use 348 gallons per acre (8 gal/1000 sq. ft.) for anchoring.

Maintenance -- Inspect all seeding areas and make needed repairs, replacements and reseedings.

**TEMPORARY SEEDING NOTES**

Apply to graded or cleared areas likely to be re-disturbed where a short-term vegetative cover is needed.

Seedbed preparation: -- Loosen upper three inches of soil by raking, disking or other acceptable means before seeding, if not previously loosened.

Soil Amendments: -- Apply 600 lbs/acre 10-10-10 fertilizer (14 lbs/1000 sq. ft.).

Seeding: -- For periods March 1 -- April 30 and from August 15 -- October 15, seed with 2-1/2 bushels per acre of annual rye (3.2 lbs/1000 sq. ft.). For the period May 1 -- August 14, seed with 3 lbs/acre of weeping lovegrass (.07 lbs/1000 sq. ft.). For the period November 16 -- February 28, protect site by applying 2 tons/acre of well anchored straw mulch and seed as soon as possible in the spring, or use sod.

Mulching: -- Apply 1-1/2 to 2 tons/acre (70 to 90 lbs/1000 sq. ft.) of unrotted weed-free, small grain straw immediately after seeding. Anchor mulch immediately after application using mulch anchoring tool or 218 gallons per acre (5 gal/1000 sq. ft.) of emulsified asphalt on flat areas. On slopes 8 feet or higher, use 348 gallons per acre (8 gal/1000 sq. ft.) for anchoring.

Refer to the 1994 MARYLAND STANDARDS AND SPECIFICATIONS FOR SOIL EROSION AND SEDIMENT CONTROL for additional rates and methods not covered.

**SEQUENCE OF CONSTRUCTION**

- CONTRACTOR SHALL OBTAIN GRADING PERMIT FROM HOWARD COUNTY DEPARTMENT OF INSPECTION, LICENSES AND PERMITS PRIOR TO BEGINNING CONSTRUCTION.
- CONTRACTOR SHALL CONTACT HOWARD COUNTY DEPARTMENT OF INSPECTION, LICENSES, AND PERMITS AT (410) 313-2455 TO SCHEDULE A PRE-CONSTRUCTION MEETING AT LEAST 72 HOURS BEFORE CONSTRUCTION IS TO BEGIN.
- INSTALL STABILIZED CONSTRUCTION ENTRANCE AS SHOWN ON PLANS. EXACT LOCATION TO BE DETERMINED IN THE FIELD WITH THE APPROVAL OF THE C.J.D. INSPECTOR.
- INSTALL SANDBAG DIVERSION AS SHOWN ON THE PLANS FOR CONSTRUCTION OF HW-1 AND OUTFALL. ANY SEDIMENT LADEN WATER ENCOUNTERED DURING HEADWALL CONSTRUCTION SHALL BE PUMPED TO A PORTABLE SEDIMENT TANK PRIOR TO DISCHARGING TO A STABLE OUTFALL DOWNSTREAM OF THE WORK AREA.
- CONSTRUCT STORM DRAIN FROM FROM HW-1 TO M-10. ALL DISTURBED AREAS SHALL BE STABILIZED WITHIN 24 HOURS OF INITIAL DISTURBANCE.
- CONSTRUCT STORM DRAIN SYSTEM ALONG ALL SAINTS ROAD. UPON COMPLETION CONTINUE WITH STORM DRAIN SYSTEMS ALONG ROBINSON BOULEVARD AND NAYLOR AVENUE. ALL DISTURBED AREA UNDER ROADS SHALL BE STABILIZED WITH GAB AND/OR PAVEMENT WITHIN 24 HOURS OF INITIAL DISTURBANCE.
- INSTALL INLET PROTECTIONS AS EACH INLET IS BUILT. CIP AT COMBINATION INLETS SHALL BE MODIFIED PER THE DETAIL FOR AN AGIP TO PROTECT THE GRATE OF THE INLET.
- CONSTRUCT CONCRETE CURB AND GUTTER ALONG ROBINSON BOULEVARD AND NAYLOR AVENUE.
- PERFORM HMA OVERLAY ALONG ROBINSON BOULEVARD AND CARBIDE GRIND AND OVERLAY ALONG NAYLOR AVENUE AND ALL SAINTS ROAD.
- ONCE ALL DISTURBED AREAS HAVE BEEN STABILIZED AND WITH APPROVAL OF THE INSPECTOR, REMOVE INLET PROTECTIONS.

**DETAIL 24 - STABILIZED CONSTRUCTION ENTRANCE**

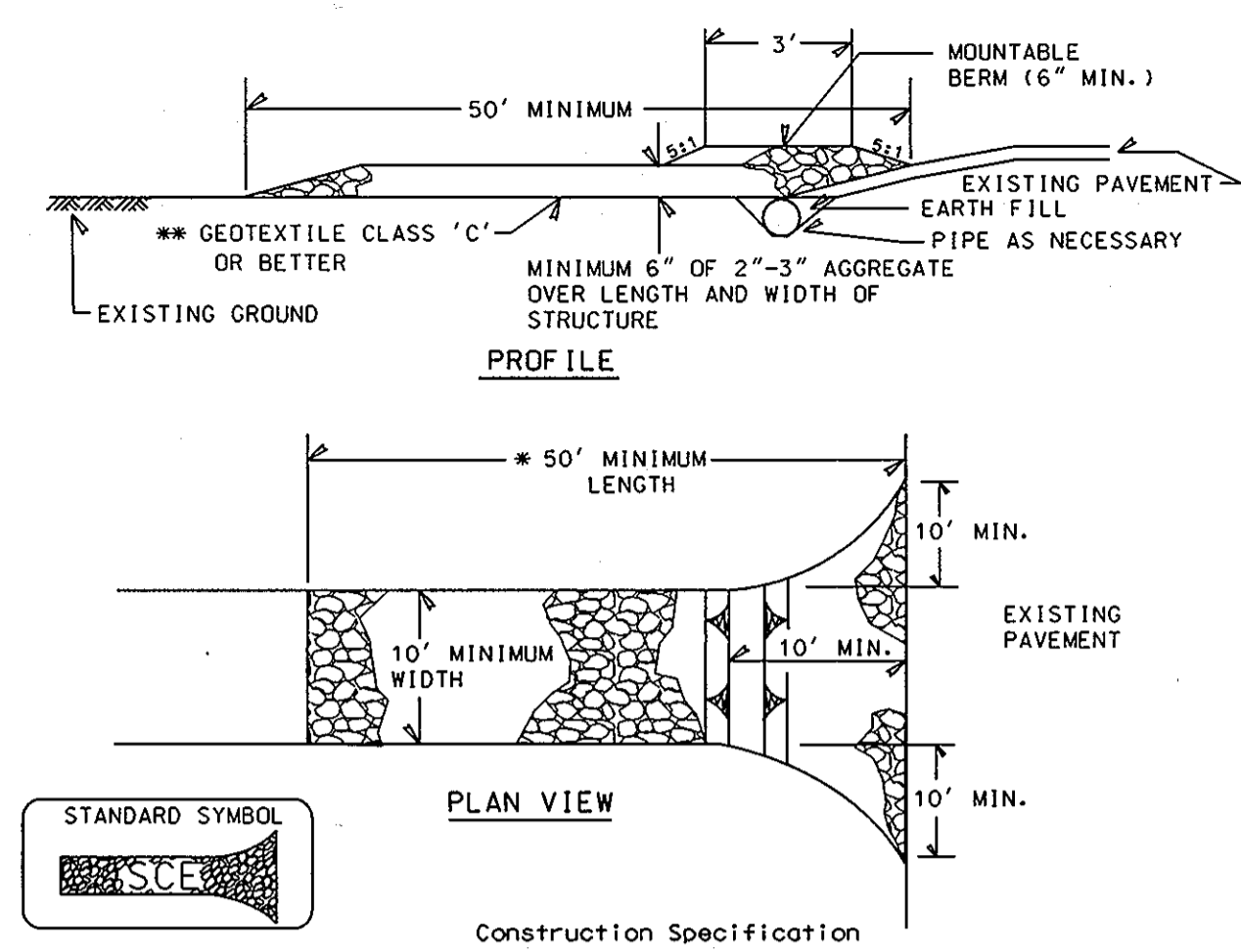

- Construction Specification**
- Length - minimum of 50' (#30' for single residence lot).
  - Width - 10' minimum, should be flared at the existing road to provide a turning radius.
  - Geotextile fabric (filter cloth) shall be placed over the existing ground prior to placing stone. \*\*The plan approval authority may not require single family residences to use geotextile.
  - Stone - crushed aggregate (2" to 3") or reclaimed or recycled concrete equivalent shall be placed at least 6" deep over the length and width of the entrance.
  - Surface Water - all surface water flowing to or diverted toward construction entrances shall be piped through the entrance, maintaining positive drainage. Pipe installed through the stabilized construction entrance shall be protected with a mounded berm with 5:1 slopes and a minimum of 6" of stone over the pipe. Pipe has to be sized according to the drainage. When the SCE is located at a high spot and has no drainage to convey a pipe will not be necessary. Pipe should be sized according to the amount of runoff to be conveyed. A 6" minimum will be required.
  - Location - A stabilized construction entrance shall be located at every point where construction traffic enters or leaves a construction site. Vehicles leaving the site must travel over the entire length of the stabilized construction entrance.

**DETAIL 23 - CURB INLET PROTECTION (COG OR COS INLETS)**

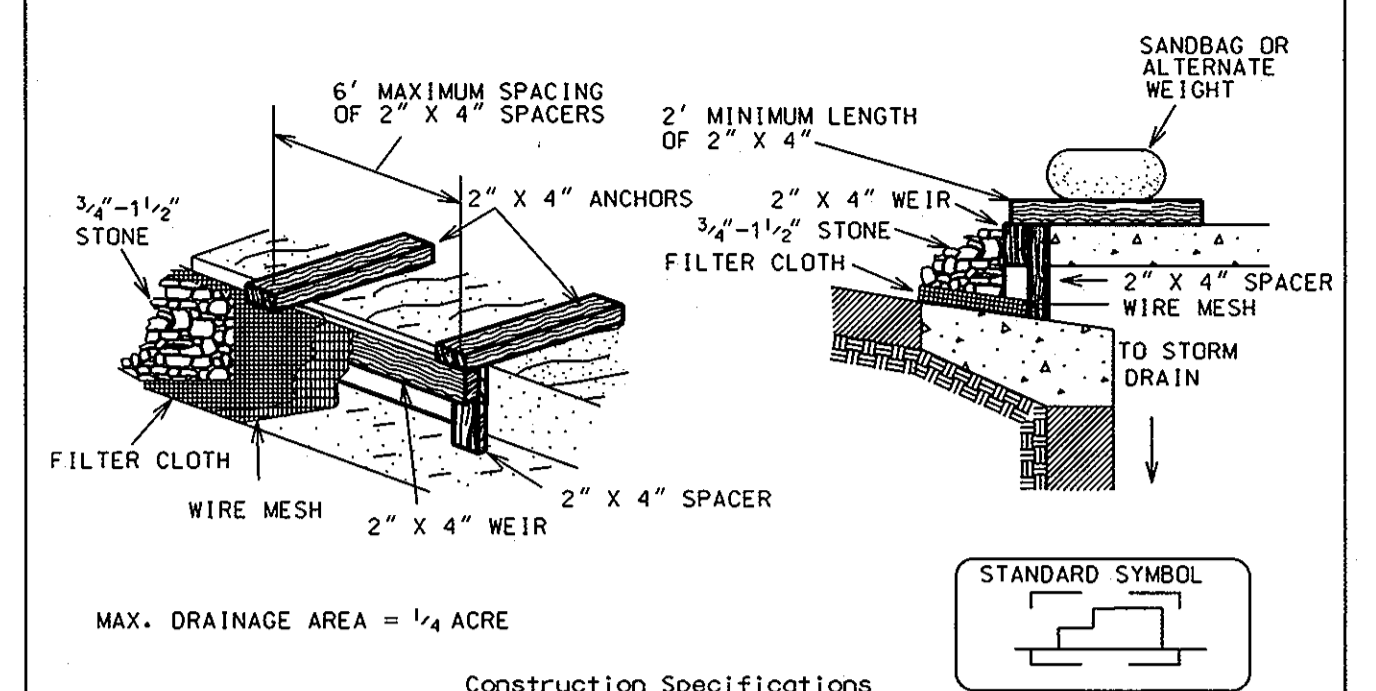

- Construction Specifications**
- Attach a continuous piece of wire mesh (30" minimum width by throat length, plus 4") to the 2" x 4" weir (measuring throat length plus 2") as shown on the standard drawing.
  - Place a continuous piece of Geotextile Class E the same as the wire mesh over the wire mesh and securely attach it to the 2" x 4" weir.
  - Securely nail the 2" x 4" weir to a 9" long vertical spacer to be located between the weir and the inlet face (max. 4' apart).
  - Place the assembly against the inlet throat and nail (minimum 2' lengths of 2" x 4" to the top of the weir at spacer locations). These 2" x 4" anchors shall extend across the inlet top and be held in place by sandbags or alternate weight.
  - The assembly shall be placed so that the end spacers are a minimum 1' beyond both ends of the throat opening.
  - Form the 1/2" x 1/2" wire mesh and the geotextile fabric to the concrete gutter and against the face of the curb on both sides of the inlet. Place clean 3/4" x 1/2" stone over the wire mesh and geotextile in such a manner to prevent water from entering the inlet under or around the geotextile.
  - This type of protection must be inspected frequently and the filter cloth and stone replaced when clogged with sediment.
  - Assure that storm flow does not bypass the inlet by installing a temporary earth or asphalt dike to direct the flow to the inlet.

**STORM DRAIN CONSTRUCTION NOTES:**

- INSTALLATION OF THE STORM DRAIN SHALL BE LIMITED TO THAT WHICH CAN BE BACKFILLED AND STABILIZED EACH WORKING DAY.
- SPOIL FROM THE TRENCHING OPERATION IS TO BE PLACED ON THE UPHILL SIDE OF CONSTRUCTION.

By the Engineer:

I certify that this plan for erosion and sediment control represents a practical and workable plan based on my personal knowledge of the site conditions and that it was prepared in accordance with the requirements of the Howard Soil Conservation District.

PAUL F. CLEMENT, P.E.      03/05/08  
 Date  
*Paul F. Clement*  
 Signature of Engineer  
 Print name below Signature

By the Developer:

I/we certify that all development and construction will be done according to this plan, and that any responsible personnel involved in the construction project will have a Certificate of Attendance at a Department of the Environment approved Training Program for the Control of Sediment and Erosion before beginning the project. I also authorize periodic on-site inspection by the Howard Soil Conservation District.

Ronald G. Lepson      3/10/08  
 Date  
*Ronald G. Lepson*  
 Signature of Developer  
 Print name below Signature

This development plan is approved for soil erosion and sediment control by the HOWARD SOIL CONSERVATION DISTRICT

John E. Rhea      3/11/08  
 Date  
 Howard SCD

FILE: G:\SW03\00683\_289w\csc\_WFCAD\wcdm\03\_03\_08.dwg 3/5/2008 8:58:07 AM

DEPARTMENT OF PUBLIC WORKS  
 HOWARD COUNTY, MARYLAND

*Steve Sharav* 3/10/08  
 DIRECTOR OF PUBLIC WORKS  
 PROJECTS DIVISION

*Paul G. Lepson* 3/10/08  
 CHIEF, BUREAU OF ENGINEERING

*Willa F. Wall* 3-10-08  
 CHIEF, BUREAU OF HIGHWAYS

**JMT**  
 JOHNSON, MIRMIRAN & THOMPSON  
 Engineering, A Brighter Future  
 72 Loveton Circle, Baltimore, Maryland 21152-0949

STATE OF MARYLAND  
 JOHN FRANKLIN CLEGG  
 REGISTERED PROFESSIONAL ENGINEER  
 03/08/08

DES:	
DRN:	
CHK:	
DATE:	BY NO. DATE

SEDIMENT AND EROSION CONTROL DETAILS AND NOTES  
 NAYLOR AVENUE & ROBINSON BOULEVARD  
 - STORM DRAIN IMPROVEMENTS

CAPITAL PROJECT No. D-1143

SCALE AS SHOWN  
 SHEET 12 OF 17

ED-1

**DETAIL 22 - SILT FENCE**

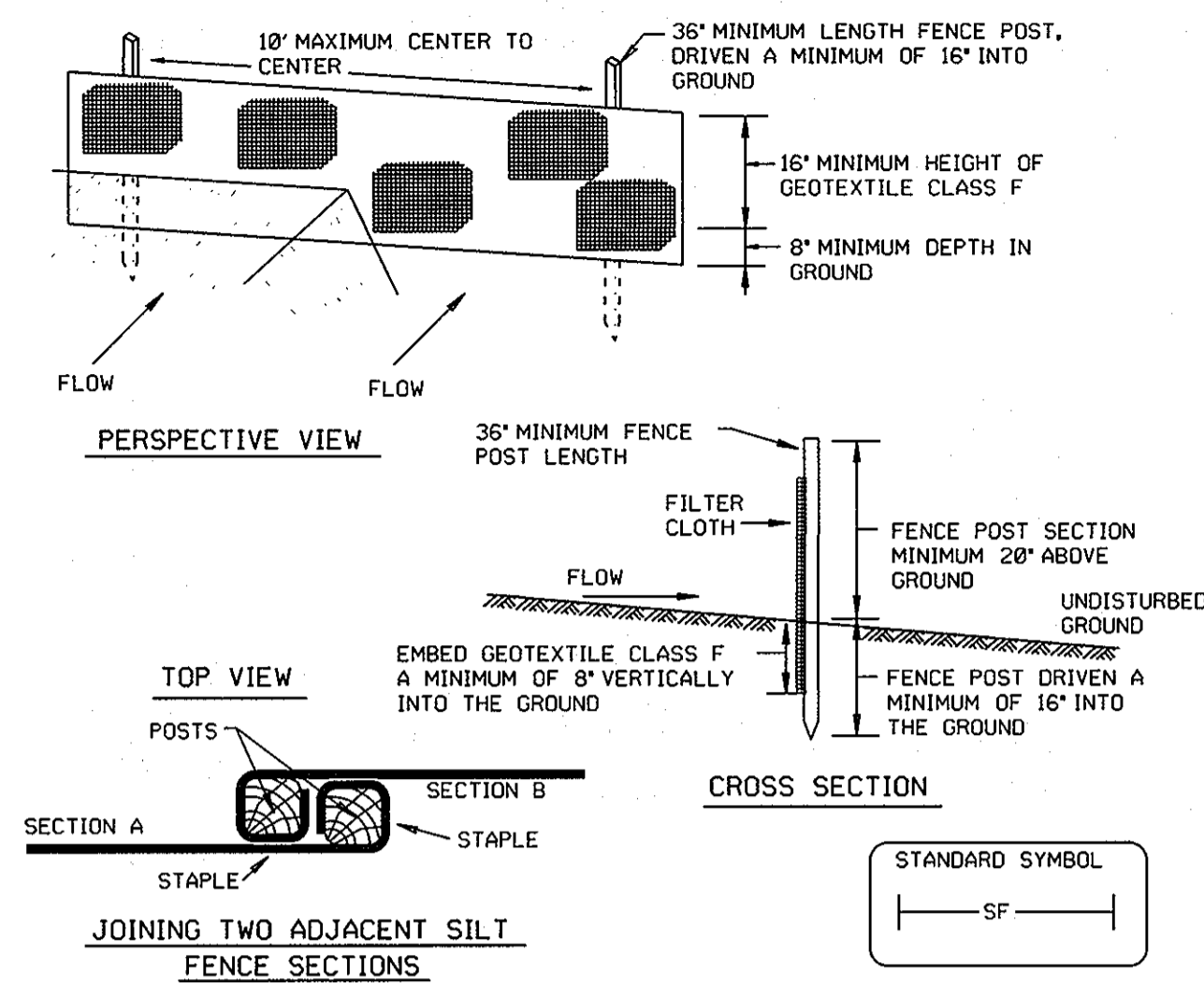

- Construction Specifications**
- Fence posts shall be a minimum of 36' long driven 16" minimum into the ground. Wood posts shall be 1 1/2" x 1 1/2" square (minimum cut) or 1 1/2" diameter (minimum) round and shall be of sound quality hardwood. Steel posts will be standard T or U section weighting not less than 1.00 pound per linear foot.
  - Geotextile shall be fastened securely to each fence post with wire ties or staples at top and mid-section and shall meet the following requirements for Geotextile Class F:
 

Tensile Strength	50 lbs/in (min.)	Test: MSMT 509
Tensile Modulus	20 lbs/in (min.)	Test: MSMT 509
Flow Rate	0.3 gal ft / minute (max.)	Test: MSMT 322
Filtering Efficiency	75% (min.)	Test: MSMT 322
  - Where ends of geotextile fabric come together, they shall be overlapped, folded and stapled to prevent sediment bypass.
  - Silt Fence shall be inspected after each rainfall event and maintained when bulges occur or when sediment accumulation reached 50% of the fabric height.

**DETAIL 23B - AT GRADE INLET PROTECTION**

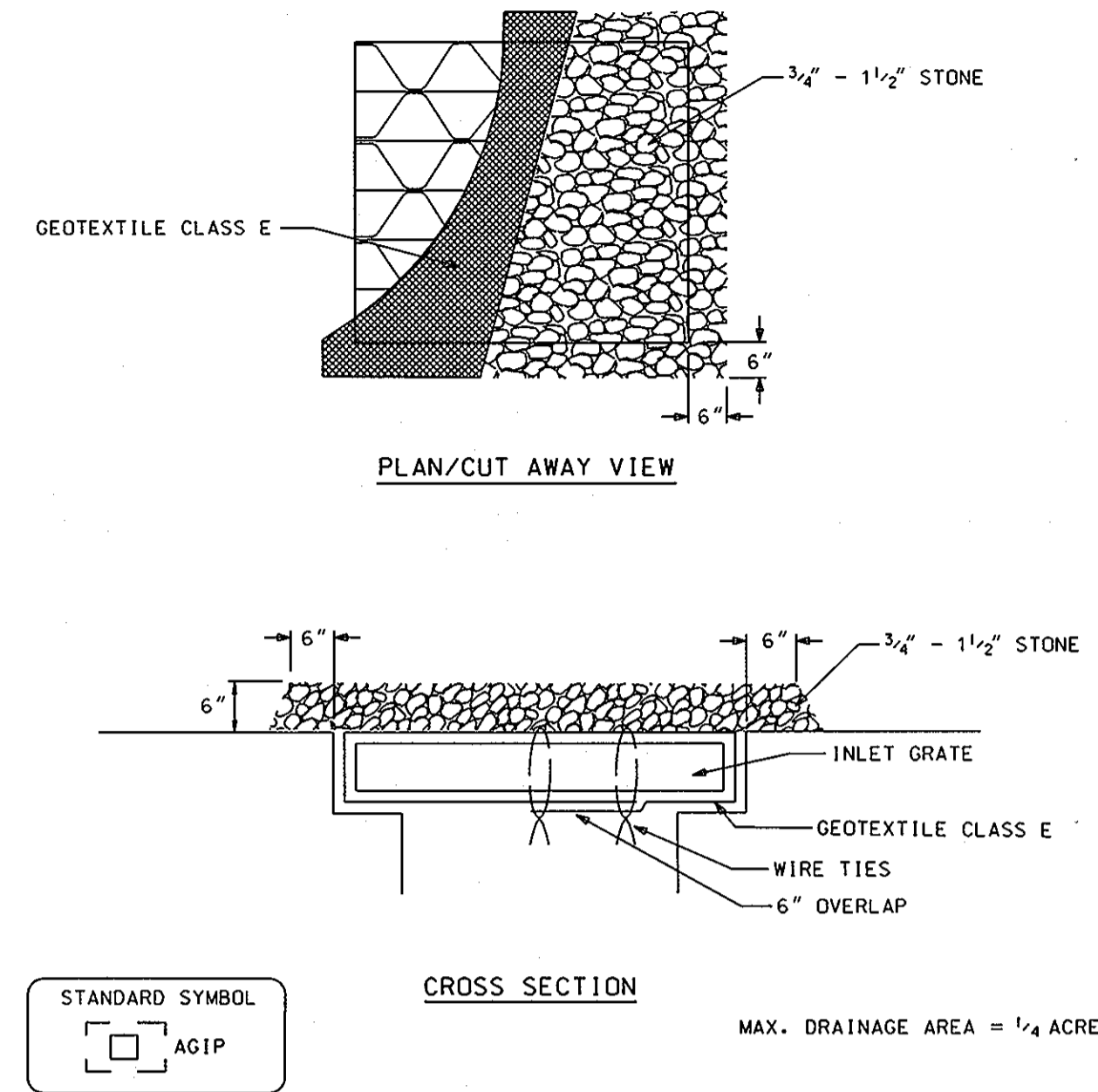

- Construction Specifications**
- Lift grate and wrap with Geotextile Class E to completely cover all openings, then set grate back in place.
  - Place 3/4" to 1 1/2" stone, 4"-5" thick on the grate to secure the fabric and provide additional filtration.

**DETAIL 1.5: SANDBAGSTONE DIVERSION**

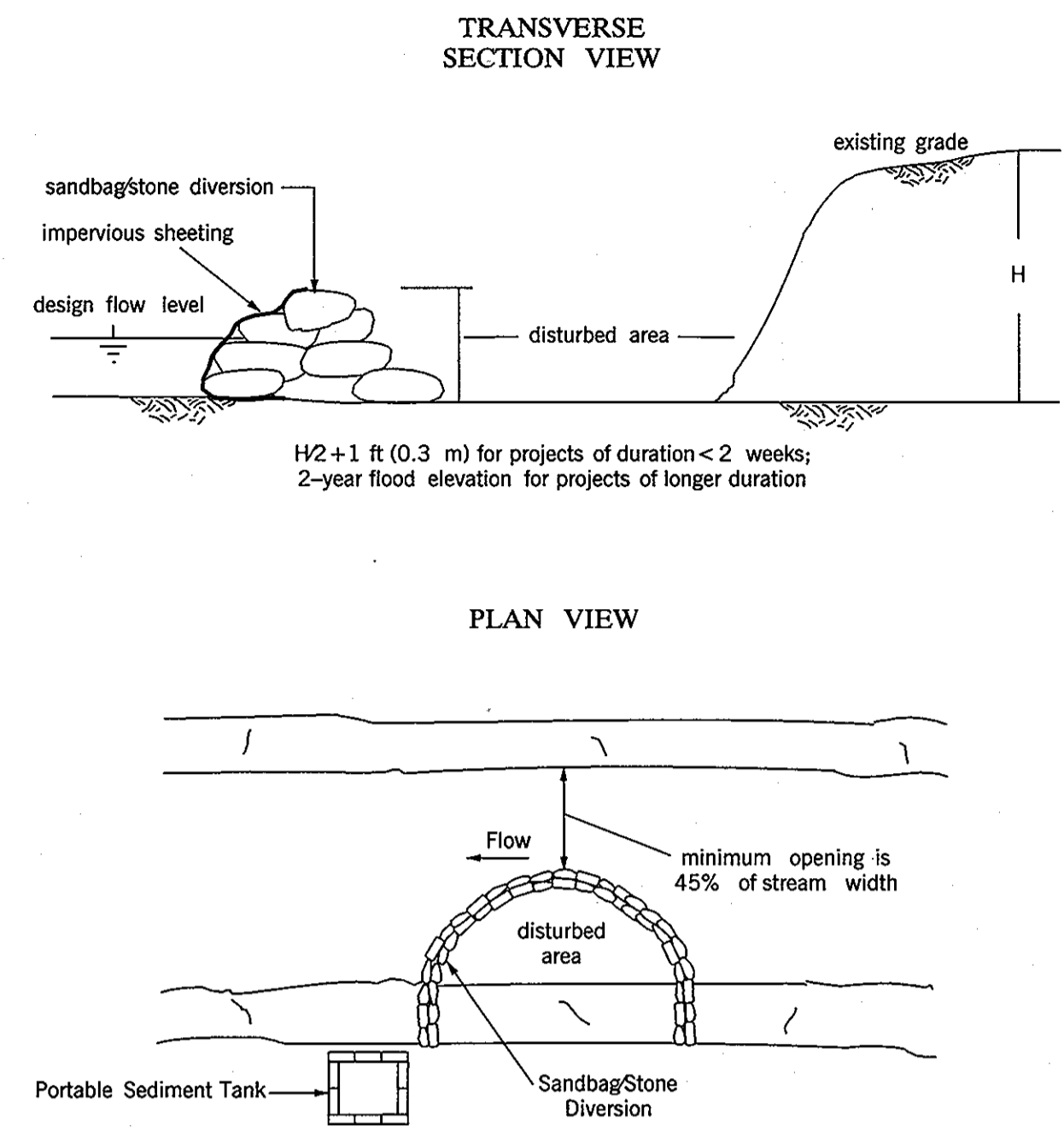

**FOR INFORMATION PURPOSES ONLY:**  
APPROXIMATE 2-YEAR FLOOD DEPTH IS 1.0 FEET. CONTRACTOR SHALL BE RESPONSIBLE FOR ACTUAL FIELD CONDITIONS AND SHALL SIZE THE DIVERSION TO HIS AND THE E&S INSPECTOR'S SATISFACTION.

FILE: S:\Users\300683...28\pwork\w\cad\dwg\DWG\106\_0208.dwg  
DATE: 3/7/2008 8:52 AM

DEPARTMENT OF PUBLIC WORKS  
HOWARD COUNTY, MARYLAND

<i>[Signature]</i> 3/10/08 DIRECTOR OF PUBLIC WORKS	<i>[Signature]</i> 3/10/08 CHIEF, BUREAU OF ENGINEERING
<i>[Signature]</i> 3/10/08 DIRECTOR OF PUBLIC WORKS	<i>[Signature]</i> 3-10-08 CHIEF, BUREAU OF HIGHWAYS

PROJECTS DIVISION

**JMT**  
JOHNSON, MIRMIRAN & THOMPSON  
Engineering A Brighter Future  
72 Loveton Circle, Baltimore, Maryland 21152-0949

STATE OF MARYLAND  
PUBLIC WORKS ADMINISTRATION  
PROFESSIONAL ENGINEER  
*[Signature]* 3/10/08

DES:				
DRN:				
CHK:				
DATE:	BY	NO.		DATE

SEDIMENT AND EROSION CONTROL DETAILS AND NOTES  
NAYLOR AVENUE & ROBINSON BOULEVARD  
- STORM DRAIN IMPROVEMENTS

CAPITAL PROJECT No. D-1143

ED-2  
SCALE AS SHOWN  
SHEET 13 OF 17

INLET PROTECTION (IP)	
IP-1	STA. 102+86, RT. - 1 EA. (D.A.=0.45 AC.)
IP-2	STA. 105+28, RT. - 1 EA. (D.A.=0.49 AC.)
IP-3	STA. 108+63, RT. - 1 EA. (D.A.=0.57 AC.)
IP-4	STA. 102+86, LT. - 1 EA. (D.A.=0.08 AC.)
IP-5	STA. 105+28, LT. - 1 EA. (D.A.=0.07 AC.)
IP-6	STA. 108+61, LT. - 1 EA. (D.A.=0.09 AC.)

CURB INLET PROTECTION AT COMINATION INLETS SHALL BE MODIFIED PER THE DETAIL FOR AT GRADE INLET PROTECTION TO PROTECT THE INLET GRATE. MODIFICATION OF INLET PROTECTION SHALL NOT BE MEASURED BUT SHALL BE INCLUDED IN THE CONTRACT UNIT PRICE FOR INLET PROTECTION.

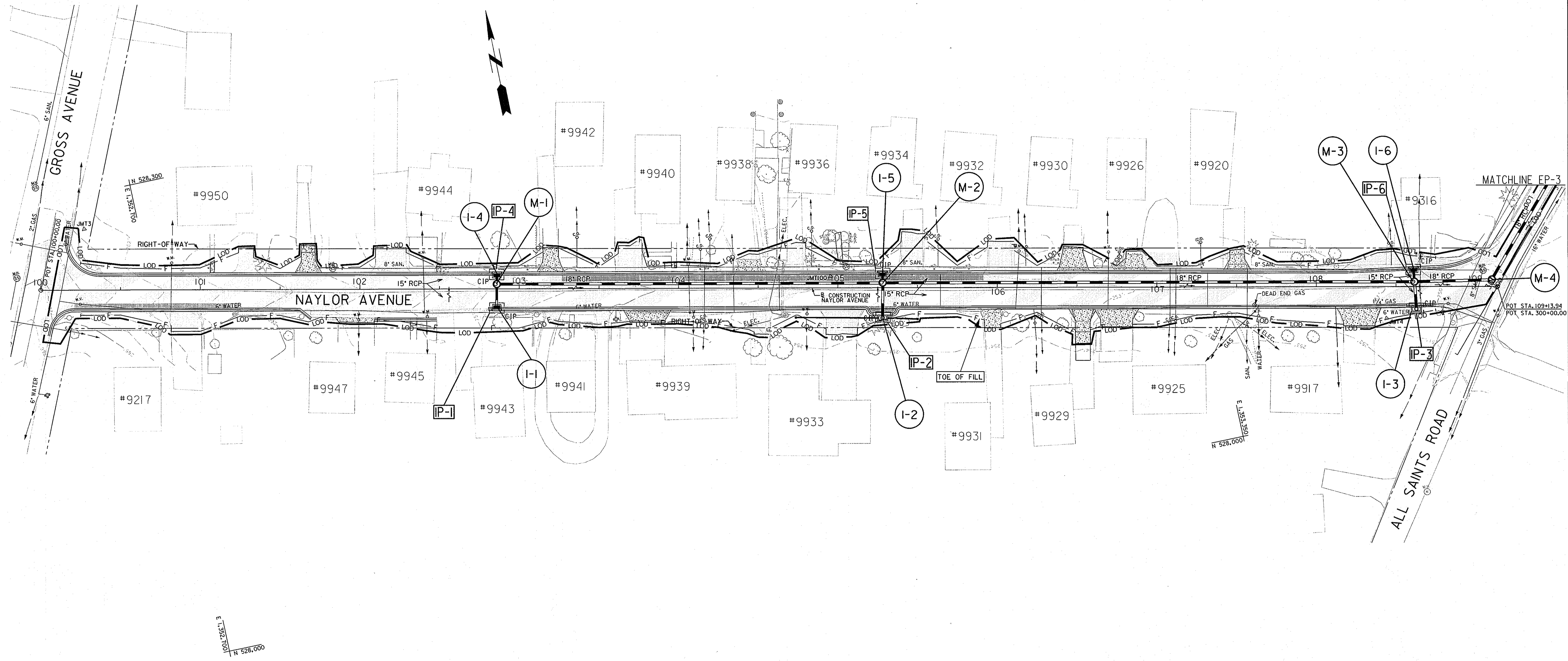

FILE: g:\plans\100663\_28\work\ep-w\cad\ep-w\ep-w\ep-w.dgn  
DATE: 3/17/2008

DEPARTMENT OF PUBLIC WORKS  
HOWARD COUNTY, MARYLAND

*Steve Shanan* 3/10/08  
DIRECTOR OF PUBLIC WORKS  
PROJECTS DIVISION

*John P. ...* 3/10/08  
CHIEF, BUREAU OF ENGINEERING

*William Z. ...* 3-10-08  
CHIEF, BUREAU OF HIGHWAYS

**JMT**  
JOHNSON, MIRMAN & THOMPSON  
Engineering A Brighter Future  
72 Loveton Circle, Baltimore, Maryland 21152-0949

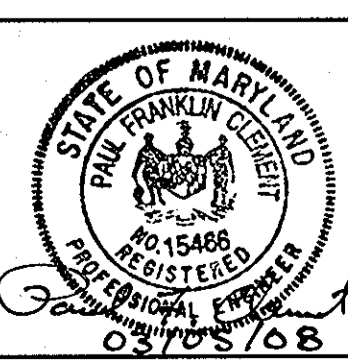

DES:	SAM				
DRN:	JMB				
CHK:	PFC				
DATE:	MAR. 2008	BY	NO.		DATE

EROSION AND SEDIMENT CONTROL PLAN  
NAYLOR AVENUE & ROBINSON BOULEVARD  
- STORM DRAIN IMPROVEMENTS

CAPITAL PROJECT No. D-1143

SCALE  
1" = 30'

SHEET  
14 OF 17

EP-1

INLET PROTECTION (IP)	
IP-7	STA. 201+82, RT. - 1 EA. (D.A.=0.91 AC.)
IP-8	STA. 203+90, RT. - 1 EA. (D.A.=1.68 AC.)
IP-9	STA. 204+97, RT. - 1 EA. (D.A.=1.61 AC.)
IP-10	STA. 205+90, RT. - 1 EA. (D.A.=0.93 AC.)
IP-13	STA. 201+82, LT. - 1 EA. (D.A.=0.29 AC.)
IP-14	STA. 203+90, LT. - 1 EA. (D.A.=0.44 AC.)
IP-15	STA. 205+90, LT. - 1 EA. (D.A.=0.94 AC.)

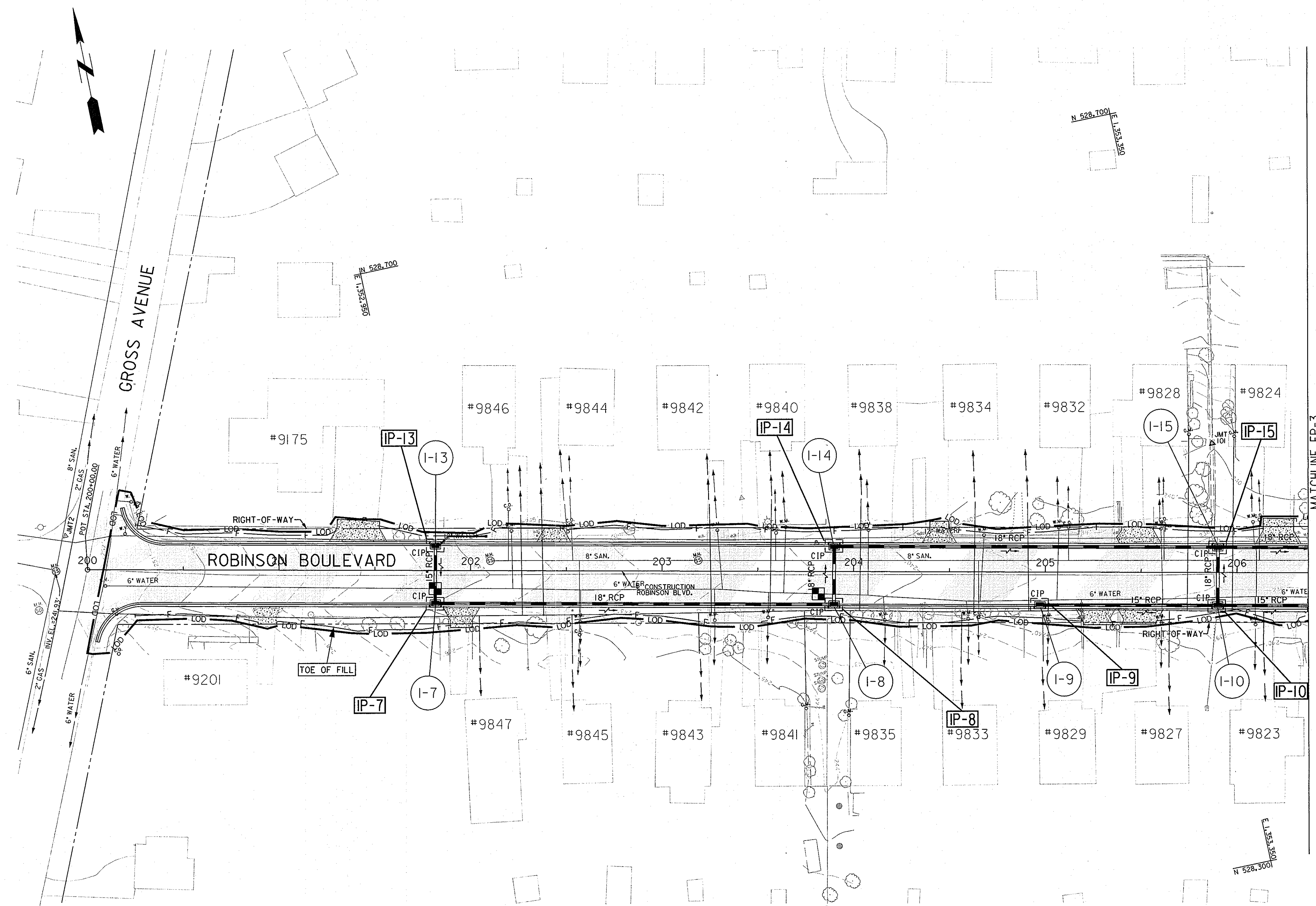

MATCHLINE EP-3

FILE: g:\u000631\_08\ep2.dwg DATE: 3/4/2008

DEPARTMENT OF PUBLIC WORKS  
HOWARD COUNTY, MARYLAND

*Steve Sharan* 3/10/08  
DIRECTOR OF PUBLIC WORKS

*William J. Hall* 3-10-08  
CHIEF, BUREAU OF HIGHWAYS

PROJECTS DIVISION

**JMPT**  
JOHNSON, MIRMIRAN & THOMPSON  
Engineering. A Brighter Future  
72 Lovston Circle Baltimore, Maryland 21152-0948

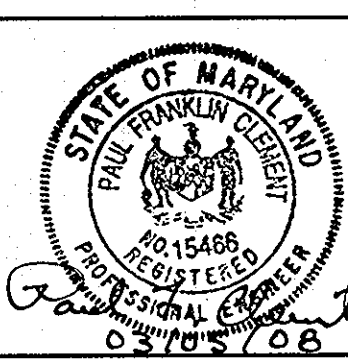

DES:	SAM				
DRN:	JMB				
CHK:	PFC				
DATE:	MAR. 2008	BY	NO.		DATE

EROSION AND SEDIMENT CONTROL PLAN  
NAYLOR AVENUE & ROBINSON BOULEVARD  
- STORM DRAIN IMPROVEMENTS

CAPITAL PROJECT No. D-1143

EP-2  
SCALE  
1" = 30'  
SHEET  
15 OF 17

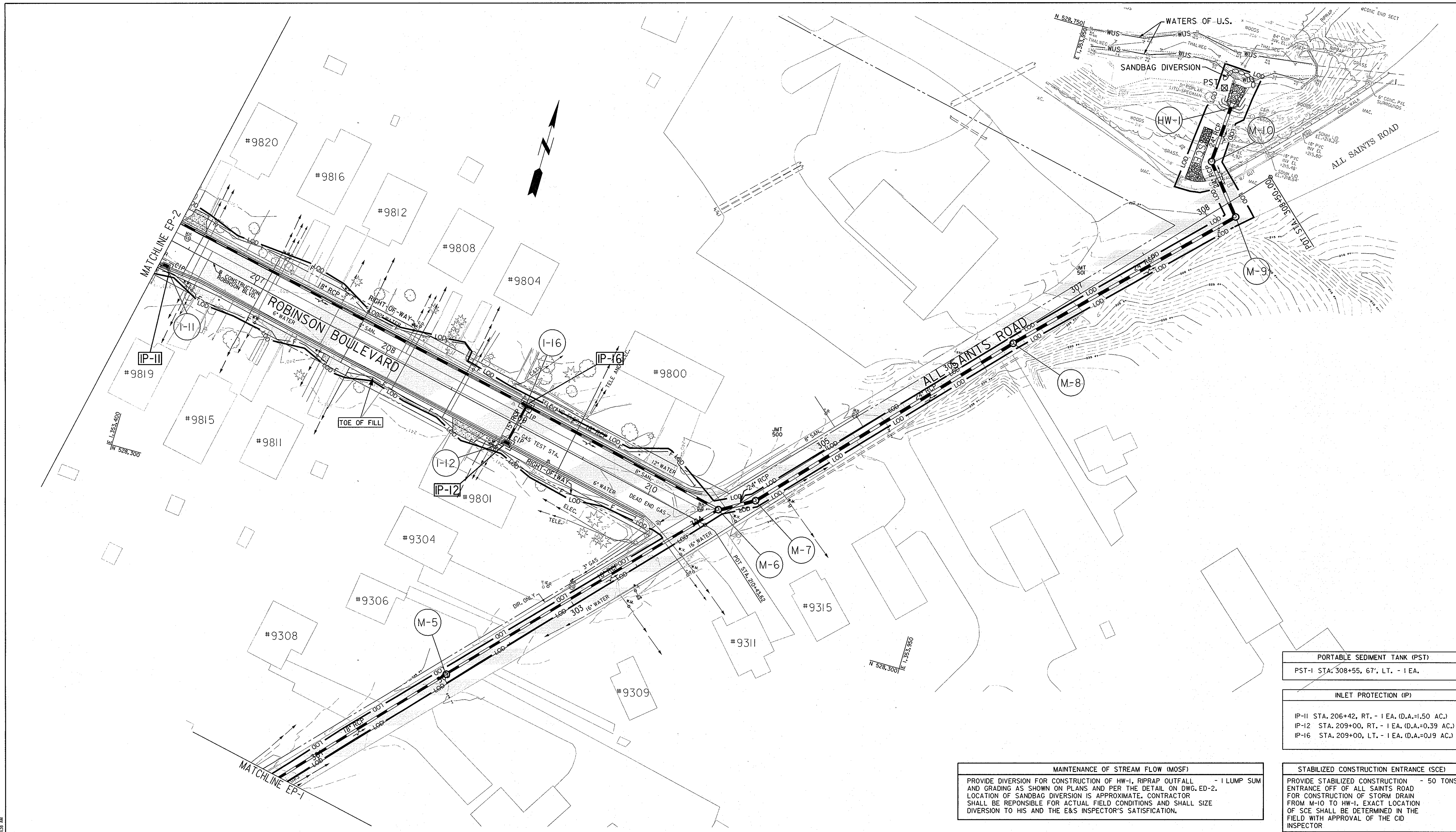

**PORTABLE SEDIMENT TANK (PST)**  
 PST-1 STA. 308+55, 67' LT. - 1 EA.

**INLET PROTECTION (IP)**  
 IP-11 STA. 206+42, RT. - 1 EA. (D.A.=1.50 AC.)  
 IP-12 STA. 209+00, RT. - 1 EA. (D.A.=0.39 AC.)  
 IP-16 STA. 209+00, LT. - 1 EA. (D.A.=0.19 AC.)

**MAINTENANCE OF STREAM FLOW (MOSF)**  
 PROVIDE DIVERSION FOR CONSTRUCTION OF HW-1, RIPRAP OUTFALL AND GRADING AS SHOWN ON PLANS AND PER THE DETAIL ON DWG. ED-2. LOCATION OF SANDBAG DIVERSION IS APPROXIMATE. CONTRACTOR SHALL BE RESPONSIBLE FOR ACTUAL FIELD CONDITIONS AND SHALL SIZE DIVERSION TO HIS AND THE E&S INSPECTOR'S SATISFACTION.

**STABILIZED CONSTRUCTION ENTRANCE (SCE)**  
 PROVIDE STABILIZED CONSTRUCTION ENTRANCE OFF OF ALL SAINTS ROAD FOR CONSTRUCTION OF STORM DRAIN FROM M-10 TO HW-1. EXACT LOCATION OF SCE SHALL BE DETERMINED IN THE FIELD WITH APPROVAL OF THE CID INSPECTOR

FILE: g:\m\300683\_2\erow\erow\m\cad\m\ep\p03\m\ep\erow.dgn  
 DATE: 3/7/2008  
 8:53:38 AM

DEPARTMENT OF PUBLIC WORKS  
 HOWARD COUNTY, MARYLAND  
 Director of Public Works: *Steve Shanan* 3/10/08  
 Chief, Bureau of Engineering: *William Z. ...* 3-10-07  
 Director of Public Works Projects Division: *Chris P. Tr...*

**JMT**  
**JOHNSON, MIRMIRAN & THOMPSON**  
 Engineering A Brighter Future  
 72 Loveton Circle, Baltimore, Maryland 21152-0949

STATE OF MARYLAND  
 PUBLIC FRANKLIN CLEVERLY  
 REGISTERED PROFESSIONAL ENGINEER  
 No. 15468  
 03/05/08

DES:	SAM				
DRN:	JMB				
CHK:	PFC				
DATE:	MAR. 2008	BY	NO.		DATE

**EP-3**  
 EROSION AND SEDIMENT CONTROL PLAN  
**NAYLOR AVENUE & ROBINSON BOULEVARD**  
**- STORM DRAIN IMPROVEMENTS**  
 CAPITAL PROJECT No. D-1143  
 SCALE: 1" = 30'  
 SHEET: 16 OF 17



GENERAL NOTES AND SEQUENCE OF CONSTRUCTION

1. NO WORK IS TO BEGIN UNTIL ALL ADVANCED WARNING SIGNS, DRUMS, CHANNELIZING DEVICES AND BARRICADES ARE IN PLACE AND OPERATIONAL.
2. THE CONTRACTOR SHALL UTILIZE A TWO LANE, TWO WAY ROADWAY FLAGGING OPERATION AS SPECIFIED IN THE MDT STATE HIGHWAY ADMINISTRATION STANDARDS FOR HIGHWAYS AND INCIDENTAL STRUCTURES, STANDARD NO. MD 104.02-10, FOR TRAFFIC CONTROL ALONG ALL ROADWAYS THAT SHALL HAVE STORM DRAIN CONSTRUCTION ALONG THEM. THE CONTRACTOR SHALL COORDINATE HIS / HER CONSTRUCTION SCHEDULE WITH RESIDENTS ALONG THE AFFECTED STREETS SO AS TO ALLOW THE RESIDENTS ENOUGH ADVANCED WARNING TO MOVE VEHICLES PARKED ON ROADWAYS OR DRIVEWAYS.
3. LANE CLOSURES SHALL BE LIMITED TO THE HOURS OF 9:00 AM THROUGH 4:00 PM MONDAY THROUGH FRIDAY. ALL ROADWAYS ARE TO BE FULLY OPERATIONAL BY 4:00 PM. THE CONTRACTOR SHALL BACKFILL AND / OR STEEL PLATE ALL OPEN TRENCHES AT THE END OF THE DAYS CONSTRUCTION.
4. THE CONTRACTOR SHALL BEGIN THE STORM DRAIN CONSTRUCTION ALONG ALL SAINTS ROAD, STA. 308+15, M-9 AND WORK ALONG ALL SAINTS ROAD TO STA. 109+14, M-4. AT THE CONCLUSION OF THE STORM DRAINS ALONG ALL SAINTS ROAD THE CONTRACTOR MAY BEGIN CONSTRUCTION ALONG NAYLOR AVE. AND ROBINSON BLVD.
5. AT THE CONCLUSION OF ALL STORM DRAIN AND CURB CONSTRUCTION ROBINSON BOULEVARD AND NAYLOR AVENUE SHALL BE OVERLAYED AS SHOWN ON THE DESIGN PLANS. ALL SAINTS ROAD SHALL BE MILLED AND OVERLAYED AS SHOWN ON THE DESIGN PLANS. THE CONTRACTOR SHALL UTILIZE A FLAGGING OPERATION FOR MILL AND OVERLAY CONSTRUCTION.

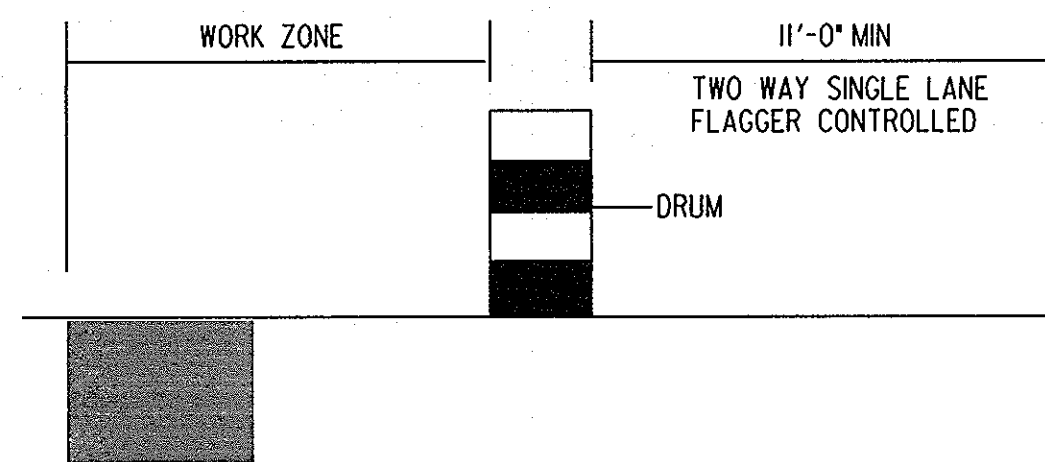

TYPICAL WORK ZONE SECTION

N.T.S.

LEGEND

TEMPORARY SIGN



96"

**NOTICE**

ROAD WORK BEGINS  
ON OR ABOUT

FOR INFO, 410-313-3440

COLORS	LEGEND	BACKGROUND
TOP -	BLACK	YELLOW
MIDDLE -	BLACK	ORANGE
BOTTOM -	BLACK	ORANGE

NOTE:  
1. THIS SIGN IS TO BE PLACED AT LOCATIONS SHOWN A MINIMUM OF TWO WEEKS PRIOR TO ANY WORK BEGINNING.

2. FONT SHALL BE TYPE D.

FILE: S:\Users\300663\_Steve\My Documents\w\cad\dwg\17-000\00663\_2641\_Signs\_Rd.dwg  
DATE: 3/7/2008 8:55:43 AM

DEPARTMENT OF PUBLIC WORKS  
HOWARD COUNTY, MARYLAND

*Steve Sharan* 3/10/08  
DIRECTOR OF PUBLIC WORKS

*Steve Sharan* 3/10/08  
DIRECTOR OF PUBLIC WORKS  
PROJECTS DIVISION

*John J. Ryan* 3/10/08  
CHIEF, BUREAU OF ENGINEERING

*Walter R. Hall* 3-10-07  
CHIEF, BUREAU OF HIGHWAYS

**JMT**  
JOHNSON, MIRMIRAN & THOMPSON  
Engineering A Brighter Future  
72 Loveton Circle, Baltimore, Maryland 21152-0949

STATE OF MARYLAND  
PAUL FRANKLIN CLEMENT  
NO. 15466  
REGISTERED PROFESSIONAL ENGINEER

*Paul Clement*  
03105108

DES:	CGM				
DRN:	RL				
CHK:	PFC				
DATE:	MAR. 2008	BY	NO.		DATE

MAINTENANCE OF TRAFFIC AND DETOUR PLAN  
NAYLOR AVENUE & ROBINSON BOULEVARD  
- STORM DRAIN IMPROVEMENTS

CAPITAL PROJECT No. D-1143

TP-1  
SCALE AS SHOWN  
SHEET 17 OF 17