

ROBERT OLIVER PLACE - ARTS WALK

OAKLAND MILLS VILLAGE CENTER

COLUMBIA, MARYLAND 21045

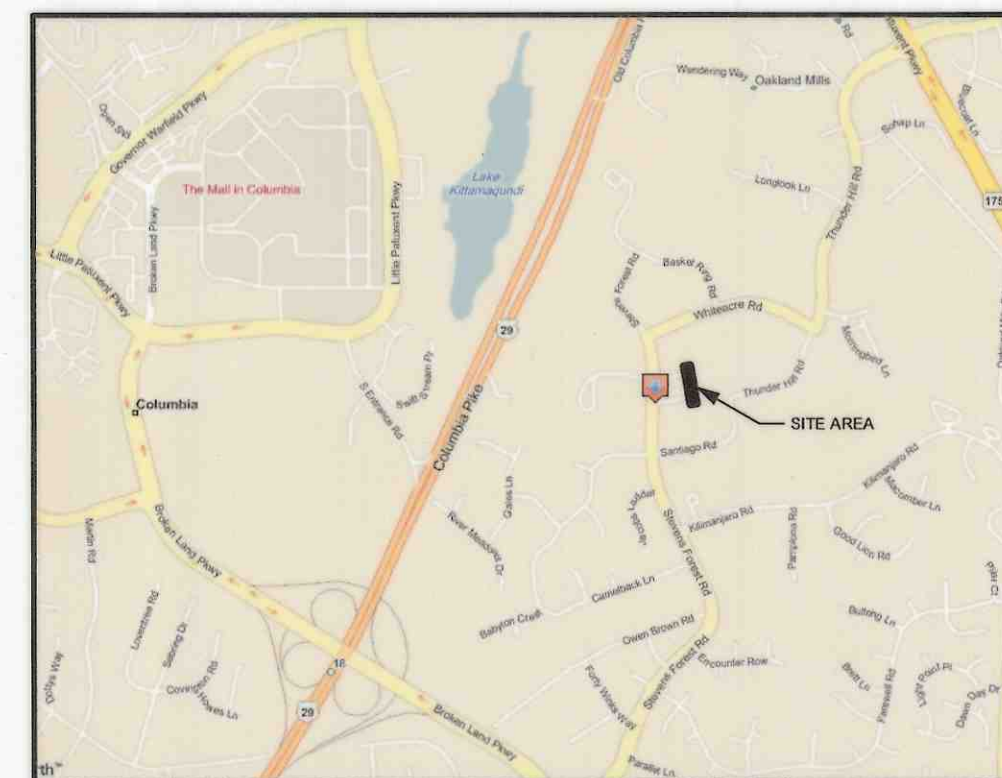

Vicinity Map
1" = 2,000'

Table Of Contents

- L1 Existing Conditions And Demolition Plan
- L2 Layout Plan
- L3 Landscape And Grading Plan
- L4 Site Details
- L5 Site Details

GENERAL NOTES

1. APPROXIMATE LOCATION OF EXISTING UTILITIES IS SHOWN FROM SELECTED AVAILABLE RECORDS. IT IS THE CONTRACTOR RESPONSIBILITY TO SOLICIT ALL UTILITY RECORDS AND VERIFY ALL EXISTING UTILITIES TO HIS OWN SATISFACTION, INCLUDING THE USE OF TEST PITS. THE CONTRACTOR SHALL TAKE ALL NECESSARY PRECAUTIONS TO PROTECT EXISTING UTILITIES AND SERVICES AND MAINTAIN UNINTERRUPTED SERVICE. ANY DAMAGE INCURRED SHALL BE REPAIRED IMMEDIATELY TO THE SATISFACTION OF THE ENGINEER AT THE CONTRACTOR'S EXPENSE.
2. IMPROVEMENTS MADE AS A RESULT OF UTILITY REPAIR WORK ARE REQUIRED TO BE RESTORED TO STANDARDS SPECIFIED BY THE HOWARD COUNTY DESIGN MANUAL (LATEST EDITION). ADDITIONAL COSTS ASSOCIATED WITH IMPROVEMENTS ABOVE THESE STANDARDS SHALL NOT BE BORNE BY THE UTILITY COMPANY. CONTRACTOR SHALL NOTIFY THE HOWARD COUNTY DEPARTMENT OF PLANNING AND ZONING AT 410-313-2350 AT LEAST FIVE WORKING DAYS BEFORE STARTING REPAIR WORK.
3. HORIZONTAL DATUM MARYLAND STATE REFERENCE SYSTEM NAD '83/91 AS PROJECTED BY HOWARD COUNTY GEODETIC CONTROL STATIONS 36BB AND 36BA.
4. VERTICAL DATUM NGVD '88 AS PROJECTED FROM HOWARD COUNTY GEODETIC BENCH MARK 36BB.
5. TOPOGRAPHIC SURVEY WAS PERFORMED USING A LEICA 3600 HDS SCANNER WITH SUPPLEMENTAL TOPOGRAPHIC FEATURES ACQUIRED USING TRADITIONAL SURVEY INSTRUMENTS AND PROCEDURES.
6. BOUNDARY AND TOPOGRAPHIC SURVEY DATA WAS RECORDED IN 2008.
7. FOR DETAILS NOT SHOWN ON THE DRAWINGS, AND FOR MATERIALS AND CONSTRUCTION METHODS, USE HOWARD COUNTY DESIGN MANUAL VOLUME IV, STANDARD SPECIFICATIONS AND DETAILS FOR CONSTRUCTION (LATEST EDITION) OR THE MSHA STANDARD DETAILS AND SPECIFICATIONS. THE CONTRACTOR SHALL HAVE A COPY OF VOLUME IV ON THE JOB.
8. CONTRACTOR SHALL NOTIFY THE FOLLOWING UTILITY COMPANIES OR AGENCIES AT LEAST FIVE WORKING DAYS BEFORE STARTING WORK SHOWN ON THESE PLANS:
STATE HIGHWAY ADMINISTRATION 410-531-5533
BALTIMORE GAS & ELECTRIC CO. CONTRACTOR SERVICES 410-850-4620
BALTIMORE GAS & ELECTRIC CO UNDERGROUND DAMAGE CONTROL SERVICES 410-859-9004
BALTIMORE GAS & ELECTRIC CO TROUBLE SHOOTING 410-298-9040
MISS UTILITY (800) 257-7777 (TO HAVE ALL UTILITIES LOCATED IN THE FIELD)
VERIZON 410-224-9452
BUREAU OF UTILITIES HOWARD CO DEPT OF PUBLIC WORKS 410-313-4900
9. TREES AND SHRUBS ARE TO BE PROTECTED FROM DAMAGE TO THE MAXIMUM EXTENT.
10. CONTRACTOR SHALL REMOVE TREES, STUMPS, AND ROOTS ALONG LINE OF EXCAVATION. PAYMENT FOR SUCH REMOVAL SHALL BE INCLUDED IN THE UNIT PRICES BID FOR CLEARING AND GRUBBING.
11. WALL CONSTRUCTION SHALL BE IN ACCORDANCE WITH THE LATEST STANDARDS AND SPECIFICATIONS OF HOWARD COUNTY PLUS MSHA STANDARDS AND SPECIFICATIONS, IF APPLICABLE.
12. THE CONTRACTOR SHALL NOTIFY THE DEPARTMENT OF PUBLIC WORKS/BUREAU OF ENGINEERING/CONSTRUCTION INSPECTION DIVISION AT 410-313-1880 AT LEAST FIVE (5) WORKING DAYS PRIOR TO THE START OF WORK.
13. PAVING SECTIONS SHALL CONFORM TO P-4 AS DETAILED IN THE HOWARD COUNTY DESIGN MANUAL (LATEST EDITION).
14. EXACT LOCATION OF PVC ELECTRICAL CROSSING AND LIGHTING HAND BOXES TO BE DETERMINED BY HOWARD COUNTY AND BGE.
15. IN ACCORDANCE WITH HOWARD COUNTY REGULATIONS, THIS PROJECT QUALIFIES FOR A FOREST CONSERVATION EXEMPTION SINCE IT IS A LINEAR PROJECT INVOLVING THE CLEARING OF LESS THAN 40,000 SQUARE FEET OF FOREST.
16. IN ACCORDANCE WITH HOWARD COUNTY REGULATIONS, THIS PROJECT QUALIFIES FOR EROSION AND SEDIMENT CONTROL EXEMPTION SINCE IT IS A LIMIT OF DISTURBANCE LESS THAN 5,000 SQUARE FEET.

SITE AREA = 18,000 SF
LIMIT OF DISTURBANCE = 4,994SF

NOTE: THE TOTAL SITE AREA INCLUDES THE LIMIT OF DISTURBANCE AREA AND THE AREA OF ASPHALT ROADWAY WHICH IS TO BE MILLED AND RE-SURFACED. THE LIMIT OF DISTURBANCE INCLUDES ONLY THE AREAS WHERE WORK IS BEING PROPOSED SUCH AS PARKING ISLANDS, ADA RAMPS, SIDEWALK, UTILITY TRENCHING AND NEW CURB.

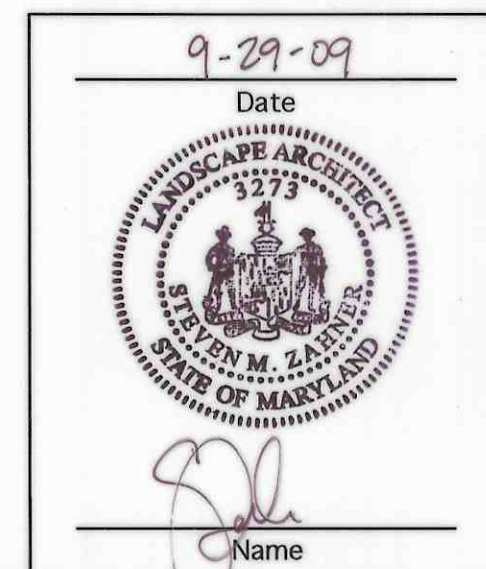

APPROVED: HOWARD COUNTY DEPARTMENT OF PUBLIC WORKS		
<i>William J. [Signature]</i>	DATE: 9-29-09	
CHIEF, BUREAU OF ENGINEERING		
<i>[Signature]</i>	DATE: 9/29/09	
CHIEF, BUREAU OF HIGHWAYS		
DATE	NO.	REVISION

DEPARTMENT OF PUBLIC WORKS HOWARD COUNTY, MARYLAND <i>[Signature]</i> 9/29/09 DIRECTOR OF PUBLIC WORKS	DEPARTMENT OF PLANNING AND ZONING HOWARD COUNTY, MARYLAND <i>[Signature]</i> 9/29/09 DIRECTOR OF PLANNING AND ZONING	SLATER ASSOCIATES, INC. 5560 Sterrett Pl. Suite 302 Columbia, MD 21044 410.992.0212 - fax 410.992.0001 - phone www.slaterassociates.com Landscape Architecture • Site Planning • Land Planning	<table border="1"> <thead> <tr> <th>DES:</th> <th>BY</th> <th>No.</th> <th>REVISION</th> <th>DATE</th> </tr> </thead> <tbody> <tr> <td>SMZ</td> <td>SMZ</td> <td>1</td> <td>CONSTRUCTION DOCUMENT REVIEW SUBMISSION</td> <td>9/19/09</td> </tr> <tr> <td>DRN:</td> <td>SMZ</td> <td>2</td> <td>FINAL CONSTRUCTION DOCUMENT SET</td> <td>9/25/09</td> </tr> <tr> <td>CHK:</td> <td>NHC</td> <td></td> <td></td> <td></td> </tr> <tr> <td>DATE:</td> <td>9/25/09</td> <td></td> <td></td> <td></td> </tr> </tbody> </table>	DES:	BY	No.	REVISION	DATE	SMZ	SMZ	1	CONSTRUCTION DOCUMENT REVIEW SUBMISSION	9/19/09	DRN:	SMZ	2	FINAL CONSTRUCTION DOCUMENT SET	9/25/09	CHK:	NHC				DATE:	9/25/09				Cover Sheet	Robert Oliver Place - Arts Walk Oakland Mills Village Center Robert Oliver Place Columbia, Maryland 21045 SCALE AS SHOWN SHEET L0
DES:	BY	No.	REVISION	DATE																										
SMZ	SMZ	1	CONSTRUCTION DOCUMENT REVIEW SUBMISSION	9/19/09																										
DRN:	SMZ	2	FINAL CONSTRUCTION DOCUMENT SET	9/25/09																										
CHK:	NHC																													
DATE:	9/25/09																													

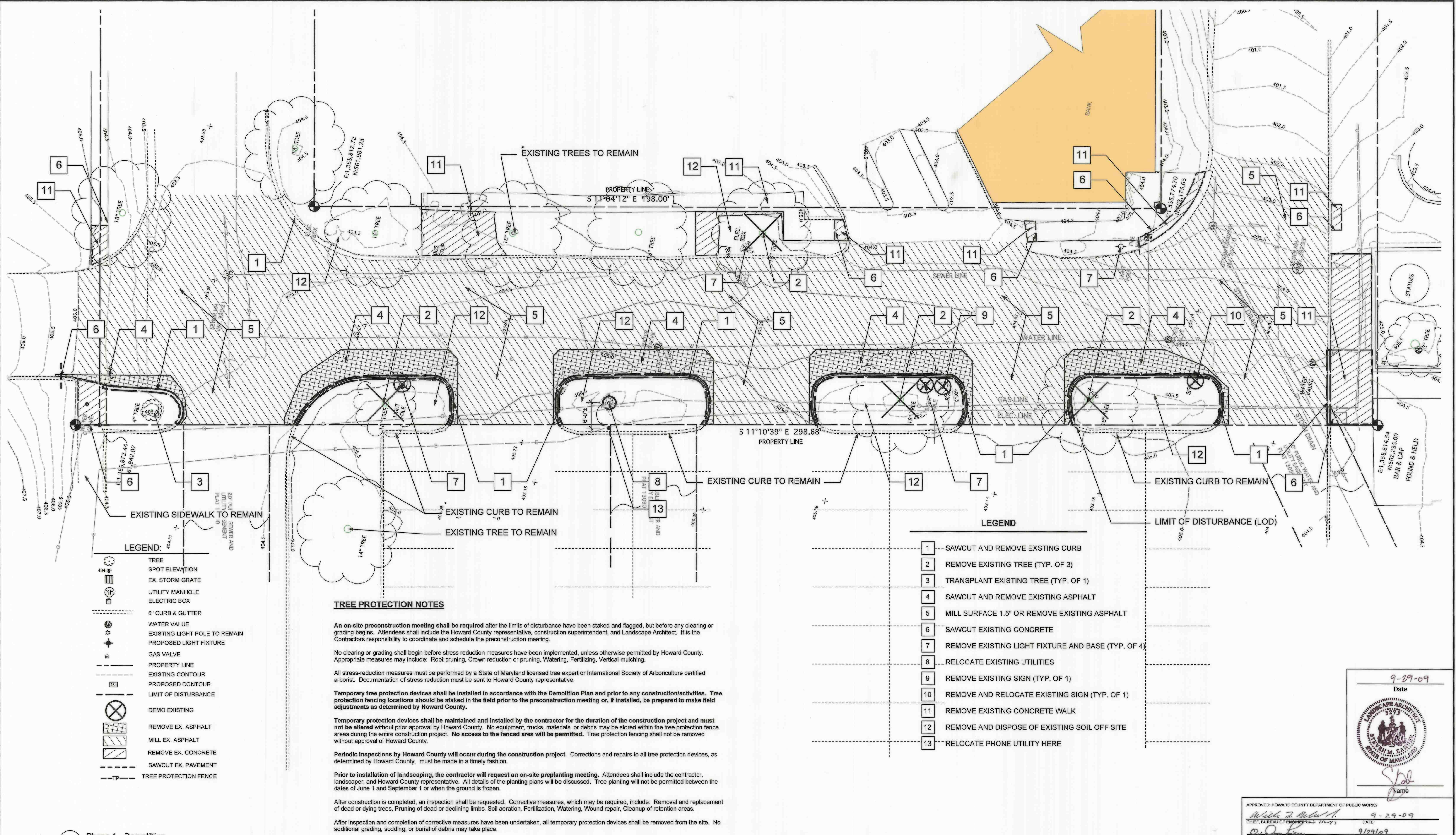

1 Phase 1 - Demolition
Scale: 1" = 10 ft

TREE PROTECTION NOTES

An on-site preconstruction meeting shall be required after the limits of disturbance have been staked and flagged, but before any clearing or grading begins. Attendees shall include the Howard County representative, construction superintendent, and Landscape Architect. It is the Contractor's responsibility to coordinate and schedule the preconstruction meeting.

No clearing or grading shall begin before stress reduction measures have been implemented, unless otherwise permitted by Howard County. Appropriate measures may include: Root pruning, Crown reduction or pruning, Watering, Fertilizing, Vertical mulching.

All stress-reduction measures must be performed by a State of Maryland licensed tree expert or International Society of Arboriculture certified arborist. Documentation of stress reduction must be sent to Howard County representative.

Temporary tree protection devices shall be installed in accordance with the Demolition Plan and prior to any construction/activities. Tree protection fencing locations should be staked in the field prior to the preconstruction meeting or, if installed, be prepared to make field adjustments as determined by Howard County.

Temporary protection devices shall be maintained and installed by the contractor for the duration of the construction project and must not be altered without prior approval by Howard County. No equipment, trucks, materials, or debris may be stored within the tree protection fence areas during the entire construction project. No access to the fenced area will be permitted. Tree protection fencing shall not be removed without approval of Howard County.

Periodic inspections by Howard County will occur during the construction project. Corrections and repairs to all tree protection devices, as determined by Howard County, must be made in a timely fashion.

Prior to installation of landscaping, the contractor will request an on-site preplanting meeting. Attendees shall include the contractor, landscaper, and Howard County representative. All details of the planting plans will be discussed. Tree planting will not be permitted between the dates of June 1 and September 1 or when the ground is frozen.

After construction is completed, an inspection shall be requested. Corrective measures, which may be required, include: Removal and replacement of dead or dying trees, Pruning of dead or declining limbs, Soil aeration, Fertilization, Watering, Wound repair, Cleanup of retention areas.

After inspection and completion of corrective measures have been undertaken, all temporary protection devices shall be removed from the site. No additional grading, sodding, or burial of debris may take place.

LEGEND

- 1 SAWCUT AND REMOVE EXISTING CURB
- 2 REMOVE EXISTING TREE (TYP. OF 3)
- 3 TRANSPLANT EXISTING TREE (TYP. OF 1)
- 4 SAWCUT AND REMOVE EXISTING ASPHALT
- 5 MILL SURFACE 1.5" OR REMOVE EXISTING ASPHALT
- 6 SAWCUT EXISTING CONCRETE
- 7 REMOVE EXISTING LIGHT FIXTURE AND BASE (TYP. OF 4)
- 8 RELOCATE EXISTING UTILITIES
- 9 REMOVE EXISTING SIGN (TYP. OF 1)
- 10 REMOVE AND RELOCATE EXISTING SIGN (TYP. OF 1)
- 11 REMOVE EXISTING CONCRETE WALK
- 12 REMOVE AND DISPOSE OF EXISTING SOIL OFF SITE
- 13 RELOCATE PHONE UTILITY HERE

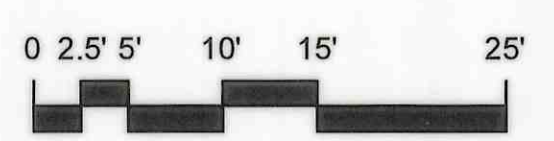

NOTES:
1. Phase 1 includes all work shown within Limit of Disturbance.
2. Future work includes crosswalk connections, concrete walk, shelter and entrance columns.

SITE AREA = 15,227 SF
LIMIT OF DISTURBANCE = 4,995 SF

9-29-09
Date

Name

APPROVED: HOWARD COUNTY DEPARTMENT OF PUBLIC WORKS		
W. M. Zappala	9-29-09	DATE
CHIEF, BUREAU OF ENGINEERING		
O. J. ...	9/29/09	DATE
CHIEF, BUREAU OF HIGHWAYS & STREETS		
DATE	NO.	REVISION

DEPARTMENT OF PUBLIC WORKS
HOWARD COUNTY, MARYLAND

DATE

DEPARTMENT OF PLANNING AND ZONING
HOWARD COUNTY, MARYLAND

DATE

SLATER ASSOCIATES, INC.
5560 Sterrett Pl. Suite 302
Columbia, MD 21044
410.992.0212 - fax
410.992.0001 - phone
www.slaterassociates.com
Landscape Architecture • Site Planning • Land Planning

DES:	BY	No.	REVISION	DATE
SMZ	SMZ	1	CONSTRUCTION DOCUMENT REVIEW SUBMISSION	9/19/09
DRN:	SMZ	2	FINAL CONSTRUCTION DOCUMENT SET	9/29/09
CHK:	NHC			
DATE:	9/25/09			

Existing Conditions & Demolition Plan

Robert Oliver Place - Arts Walk
Oakland Mills Village Center
Robert Oliver Place Columbia, Maryland 21045

SCALE AS SHOWN
SHEET **L1**

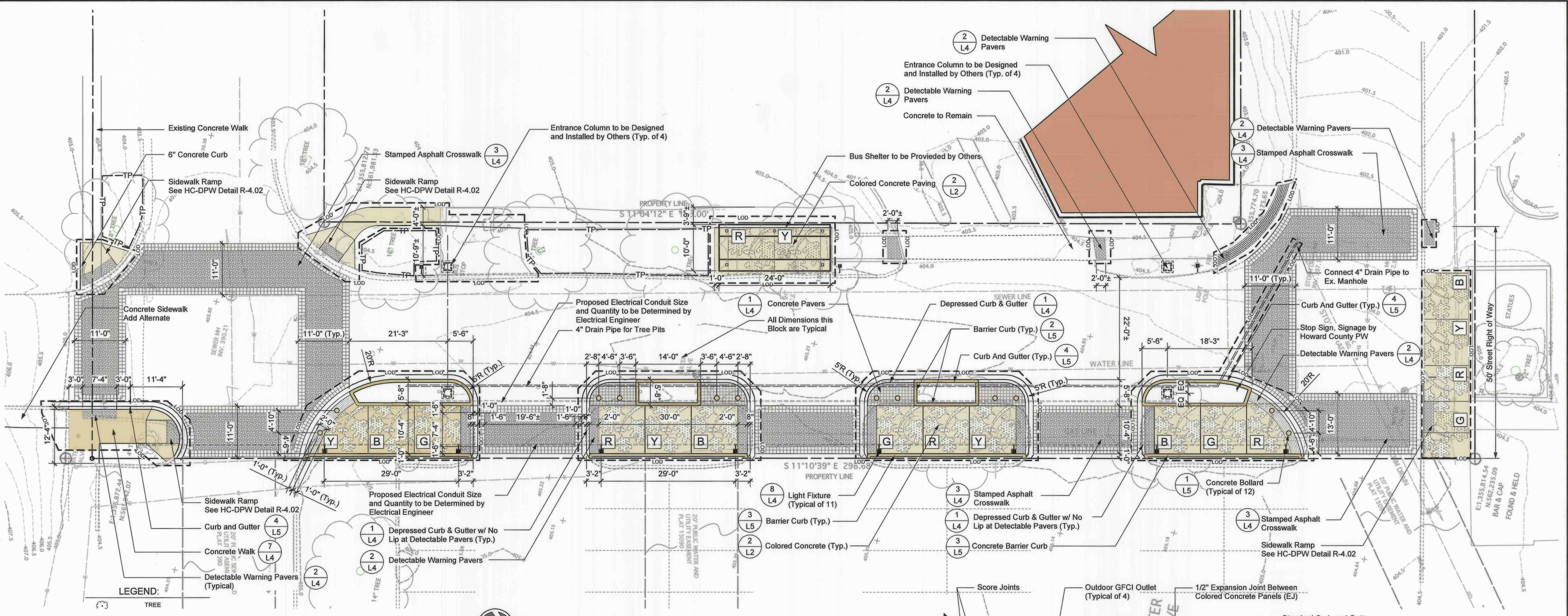

1 Layout Plan
Scale: 1" = 10 ft

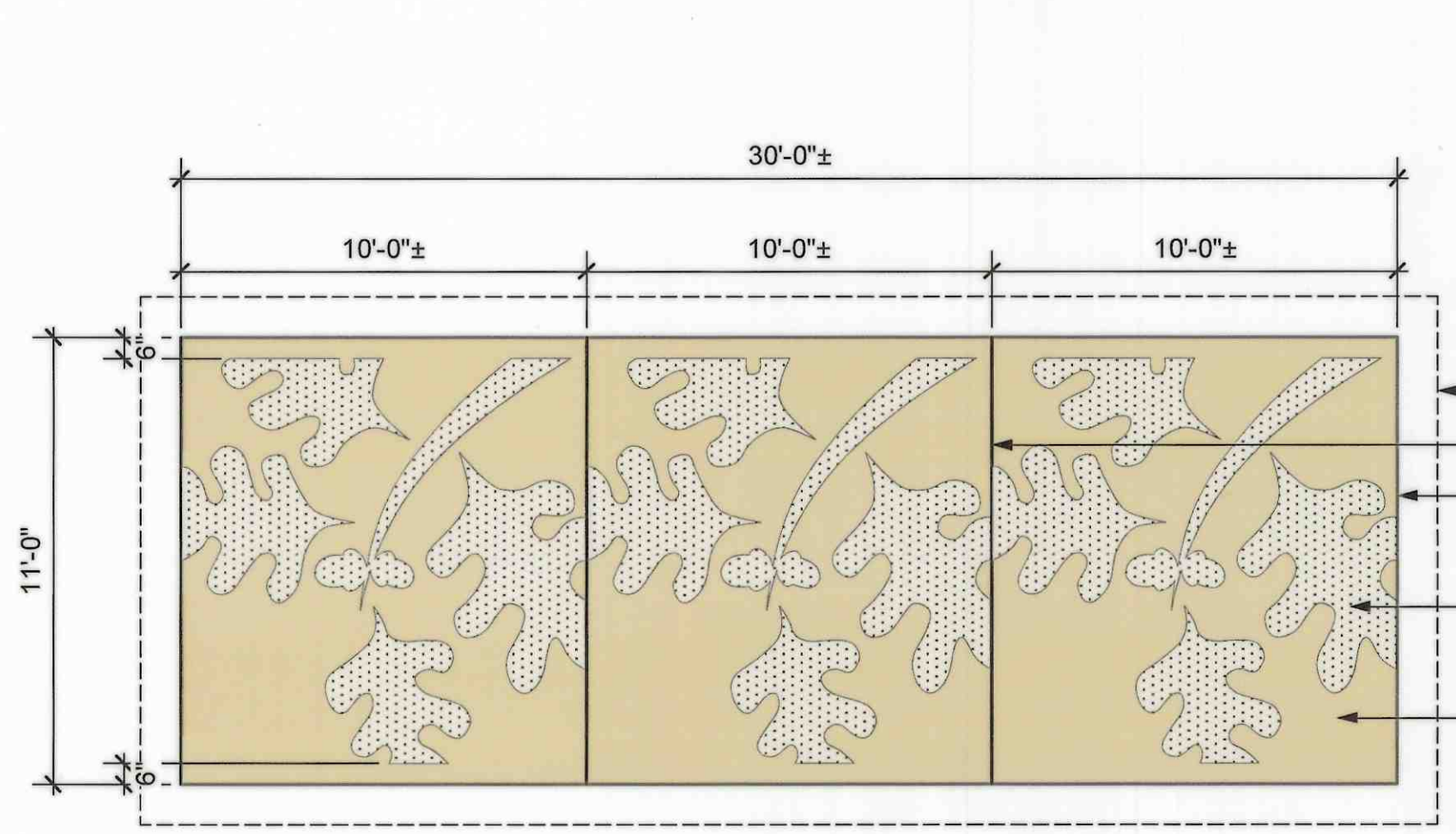
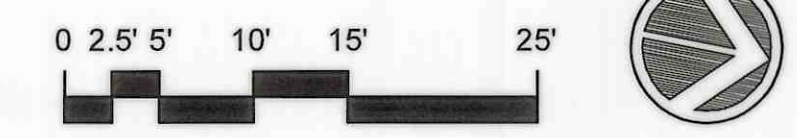

2 Oakland Mills Leaf Pattern
Scale: 1/4" = 1'-0"

COLOR KEY

R	TILE RED A-28
Y	SANDSTONE CREAM 4630
B	BLUE SMOKE 1138-S
G	MUTED GREEN A-85

12'X12' TEMPLATE BOUNDARY
1/2" EXPANSION JOINT
TYPICAL LIMITS OF COLORED CONCRETE
LEAF AREA TO BE SANDBLASTED ONTO COLORED CONCRETE WALK
COLORED CONCRETE WALK SEE PLAN FOR COLOR LOCATIONS (NO SANDBLAST) SEE DETAIL 6/L4

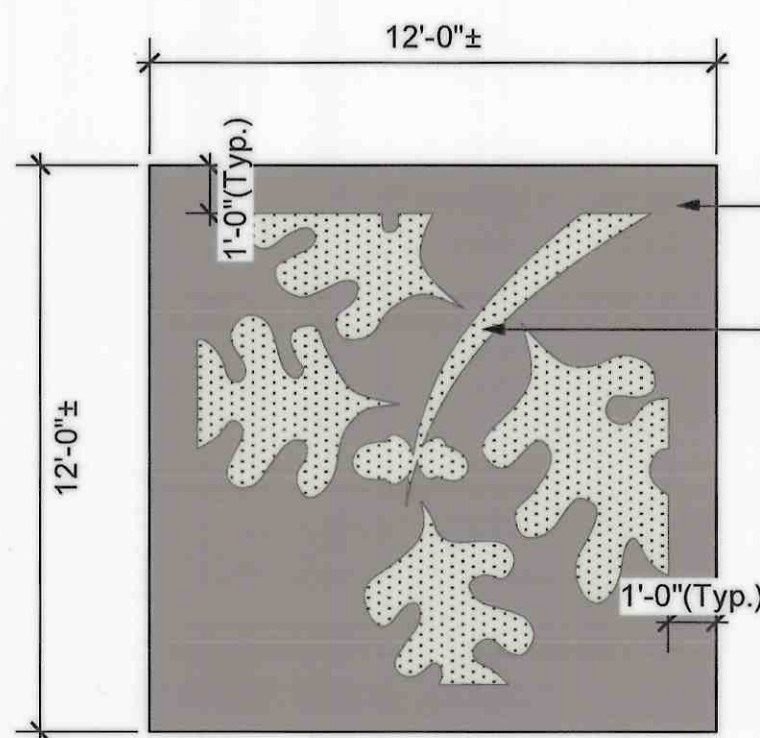

NOTES:
1. EACH 10'X11' CONCRETE TO BE SEPARATED BY EXPANSION JOINT AND WILL HAVE (1) OF FOUR DIFFERENT COLORS. SEE DETAIL 6/L4.
2. SUBMIT SHOP DRAWINGS FOR APPROVAL OF TEMPLATE.
3. CONTRACTOR TO CONSTRUCT A 6'X6' MOCK PANEL OF CONCRETE WALK WITH COLOR AND SANDBLASTED LEAVES FOR APPROVAL BY OWNER PRIOR TO CASTING ANY CONCRETE WALK.

3 Sandblast Template
Scale: 1/4" = 1'-0"

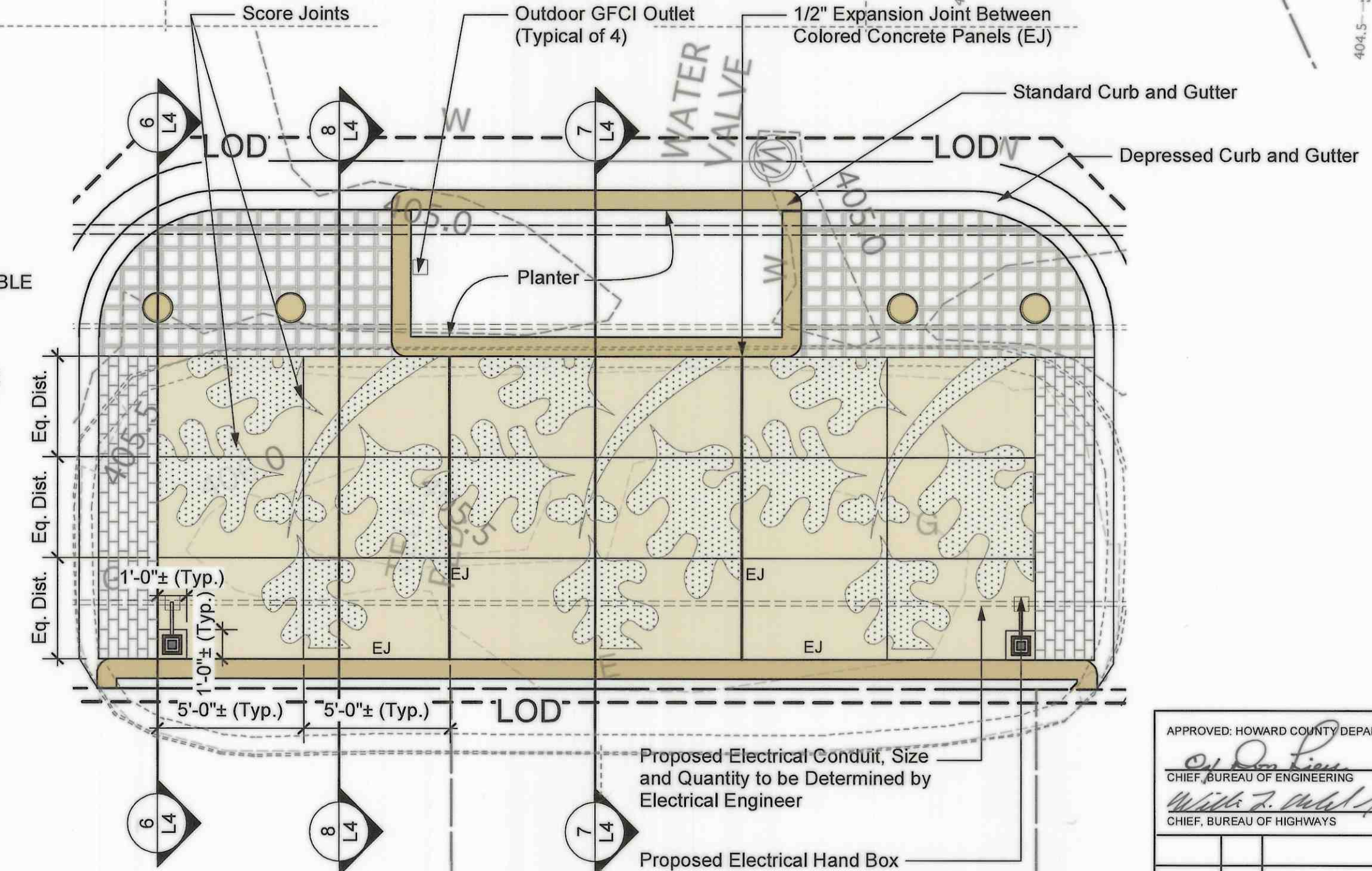

4 Concrete Scoring and Expansion Joints
Scale: 1/4" = 1'-0"

9-29-09
Date

Name

APPROVED: HOWARD COUNTY DEPARTMENT OF PUBLIC WORKS

CHIEF, BUREAU OF ENGINEERING	9/29/09
CHIEF, BUREAU OF HIGHWAYS	9-29-09

Note: Proposed electrical hand box and pvc crossing location to be determined by BGE according to Howard County specifications.

DATE	NO.	REVISION

DEPARTMENT OF PUBLIC WORKS
HOWARD COUNTY, MARYLAND

DEPARTMENT OF PLANNING AND ZONING
HOWARD COUNTY, MARYLAND

Raymond A. Balbo
DIRECTOR OF PUBLIC WORKS

Paul H. Cullen
DIRECTOR OF PLANNING AND ZONING

SLATER ASSOCIATES, INC.
Landscape Architecture • Site Planning • Land Planning

5560 Sterrett Pl. Suite 302
Columbia, MD 21044
410.992.0212 - fax
410.992.0001 - phone
www.slaterassociates.com

DES.	BY	No.	REVISION	DATE
SMZ	SMZ	1	CONSTRUCTION DOCUMENT REVIEW SUBMISSION	5/19/09
DRN: SMZ	SMZ	2	FINAL CONSTRUCTION DOCUMENT SET	9/25/09
CHK: NHC				
DATE:	9/25/09			

Layout Plan

Robert Oliver Place - Arts Walk
Oakland Mills Village Center
Robert Oliver Place Columbia, Maryland 21045

SCALE AS SHOWN
SHEET **L2**

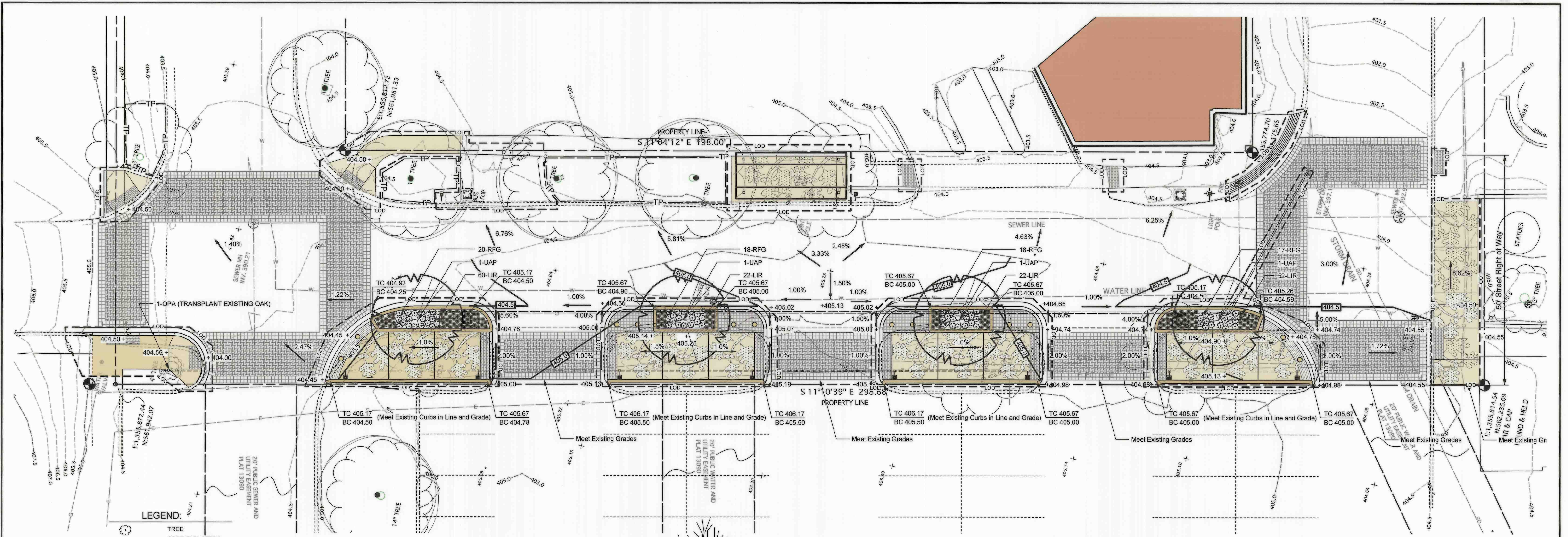

- LEGEND:**
- TREE
 - SPOT ELEVATION
 - EX. STORM GRATE
 - UTILITY MANHOLE
 - ELECTRIC BOX
 - 6" CURB & GUTTER
 - WATER VALVE
 - EXISTING LIGHT POLE TO REMAIN
 - PROPOSED LIGHT FIXTURE
 - GAS VALVE
 - PROPERTY LINE
 - EXISTING CONTOUR
 - PROPOSED CONTOUR
 - LIMIT OF DISTURBANCE

1 Landscape Plan
Scale: 1" = 10 ft

- NOTE:**
- CONTRACTOR TO VERIFY ACCURACY OF ALL PROPOSED SPOT ELEVATIONS AND SLOPES.
 - ALL SIDEWALKS AND CROSSWALKS SHALL NOT EXCEED A 2% CROSS SLOPE.

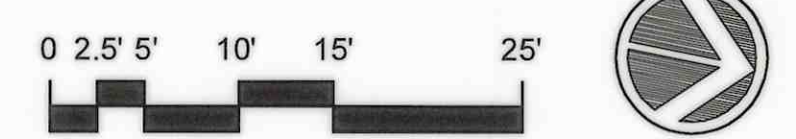

Plant List				
Qty	Symbol	Botanical Name	Common Name	Scheduled Size
Trees				
1	QPA	Quercus palustris	Pin Oak	Transplant Existing Tree
4	UAP	Ulmus americana 'Princeton'	Princeton American Elm	B&B, 2 1/2-3" cal., 12-14' hgt.
Perennials				
156	LIR	Liriope muscari 'Big Blue'	Big Blue Lily Turf	#1 Container
73	RFG	Rudbeckia fulgida	Black Eyed Susan	#1

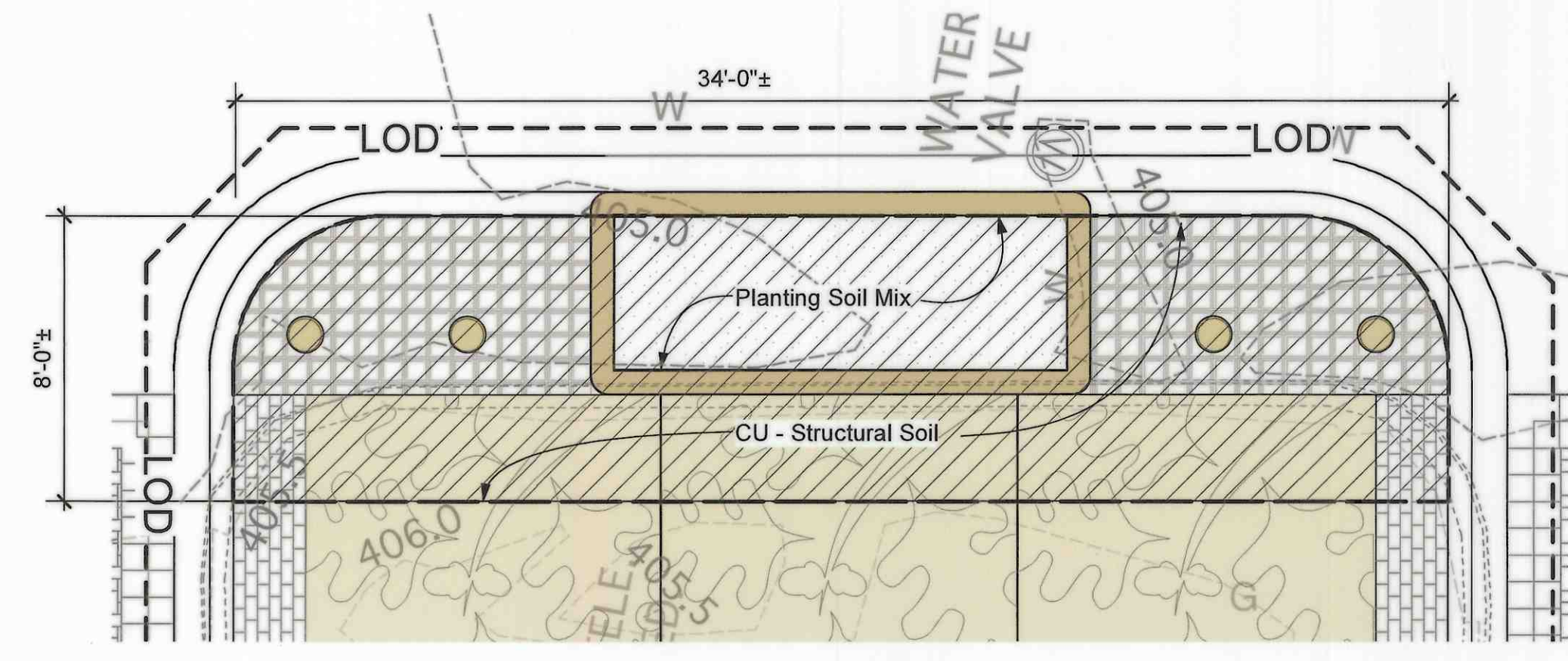

2 Limits of CU-Structural Soil
Scale: 1/4" = 1'-0"

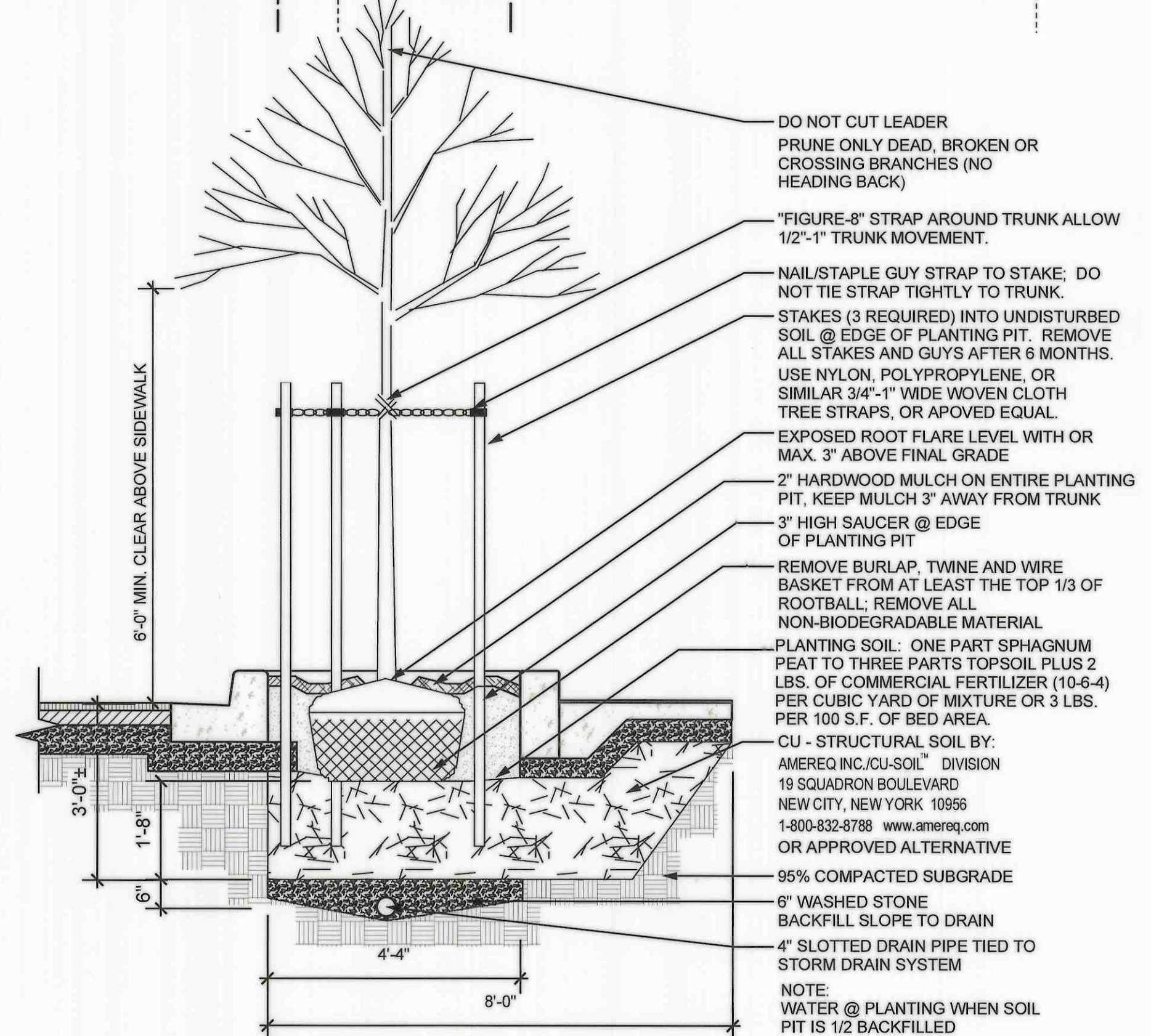

3 Street Tree Detail
Scale: 1/2" = 1'-0"

9-29-09
Date

Name

APPROVED: HOWARD COUNTY DEPARTMENT OF PUBLIC WORKS

CHIEF, BUREAU OF ENGINEERING	9/29/09
CHIEF, BUREAU OF HIGHWAYS	9-29-09

DEPARTMENT OF PUBLIC WORKS HOWARD COUNTY, MARYLAND 	DEPARTMENT OF PLANNING AND ZONING HOWARD COUNTY, MARYLAND 	SLATER ASSOCIATES, INC. 5560 Sterrett Pl, Suite 302 Columbia, MD 21044 410.992.0212 - fax 410.992.0001 - phone www.slaterassociates.com Landscape Architecture • Site Planning • Land Planning	<table border="1"> <thead> <tr> <th>DES:</th> <th>BY:</th> <th>No.</th> <th>REVISION</th> <th>DATE</th> </tr> </thead> <tbody> <tr> <td>SMZ</td> <td>SMZ</td> <td>1</td> <td>CONSTRUCTION DOCUMENT REVIEW SUBMISSION</td> <td>5/19/09</td> </tr> <tr> <td>DRN:</td> <td>SMZ</td> <td>2</td> <td>FINAL CONSTRUCTION DOCUMENT SET</td> <td>9/25/09</td> </tr> <tr> <td>CHK:</td> <td>NHC</td> <td></td> <td></td> <td></td> </tr> <tr> <td>DATE:</td> <td colspan="4">9/25/09</td> </tr> </tbody> </table>	DES:	BY:	No.	REVISION	DATE	SMZ	SMZ	1	CONSTRUCTION DOCUMENT REVIEW SUBMISSION	5/19/09	DRN:	SMZ	2	FINAL CONSTRUCTION DOCUMENT SET	9/25/09	CHK:	NHC				DATE:	9/25/09				Landscape and Grading Plan	Robert Oliver Place - Arts Walk Oakland Mills Village Center Robert Oliver Place Columbia, Maryland 21045	SCALE AS SHOWN SHEET L3
DES:	BY:	No.	REVISION	DATE																											
SMZ	SMZ	1	CONSTRUCTION DOCUMENT REVIEW SUBMISSION	5/19/09																											
DRN:	SMZ	2	FINAL CONSTRUCTION DOCUMENT SET	9/25/09																											
CHK:	NHC																														
DATE:	9/25/09																														

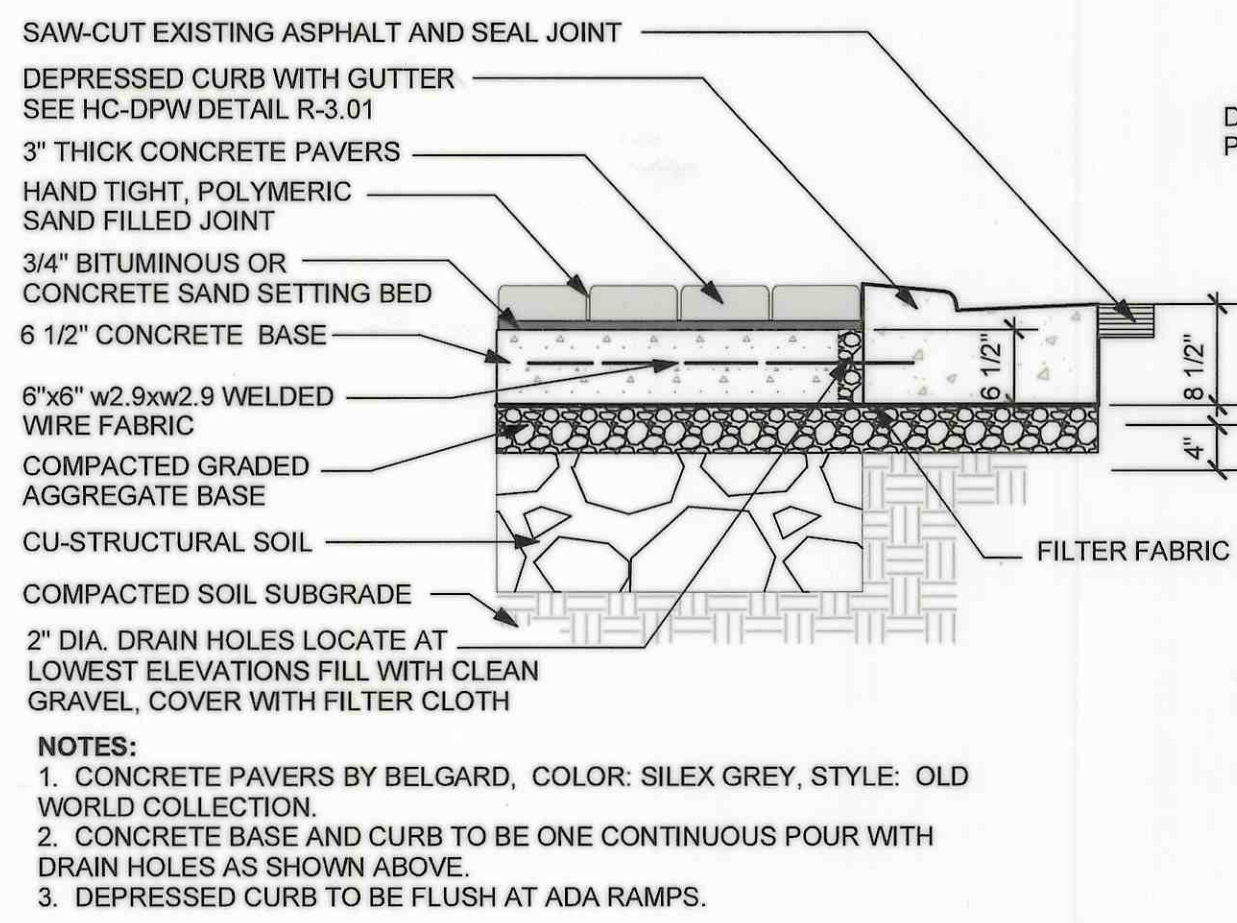

1 Cobble Paving
Scale: 3/4\"/>

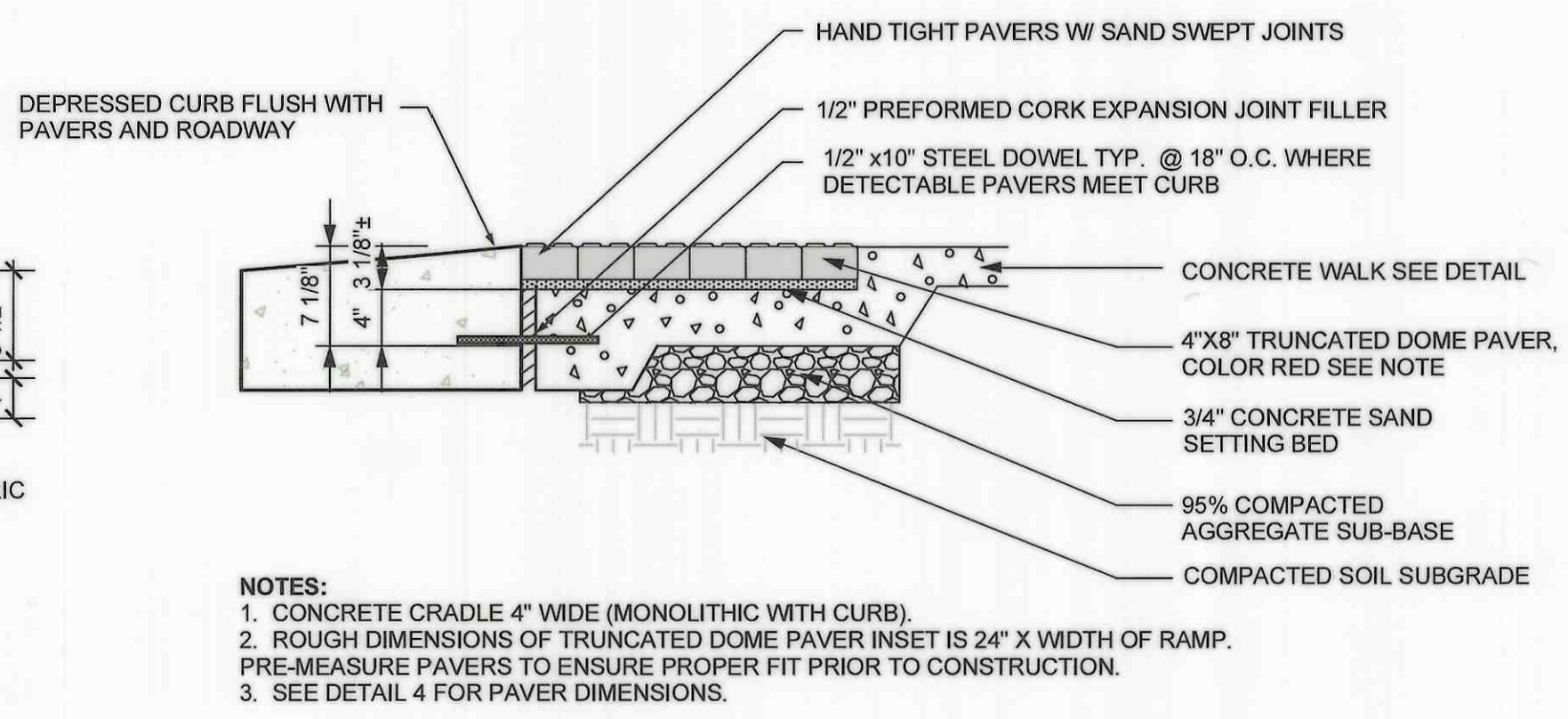

2 Detectable Paver Insert
Scale: 1\"/>

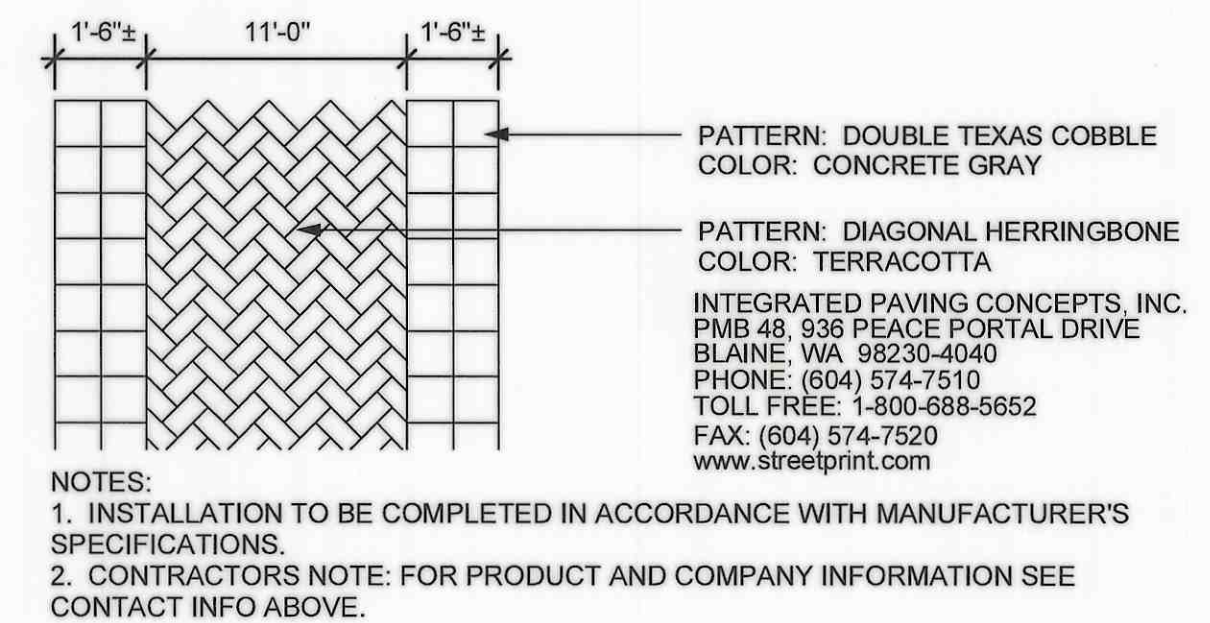

3 Crosswalk Pattern
Scale: 3/4\"/>

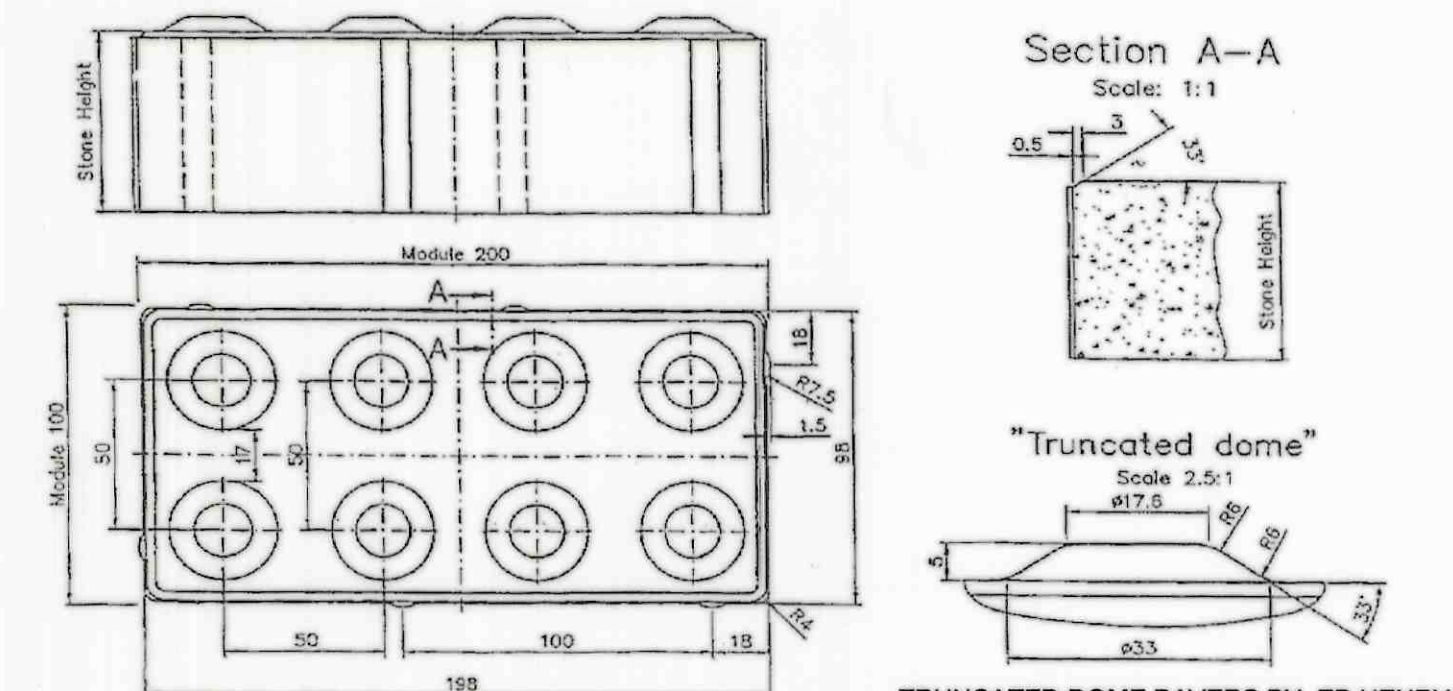

4 Detectable Paver
Scale: 1/8\"/>

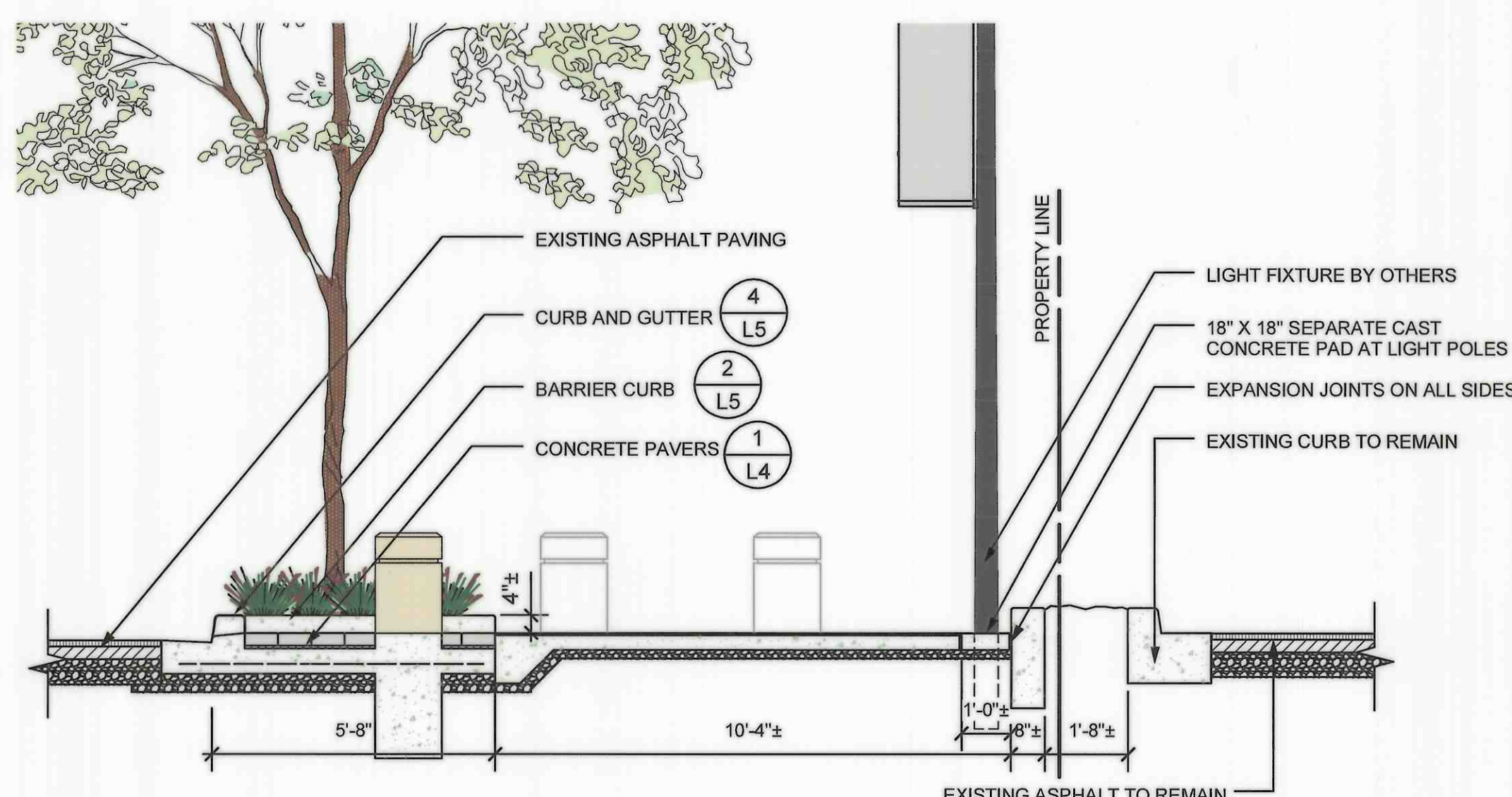

5 Bollard Section
Scale: 3/8\"/>

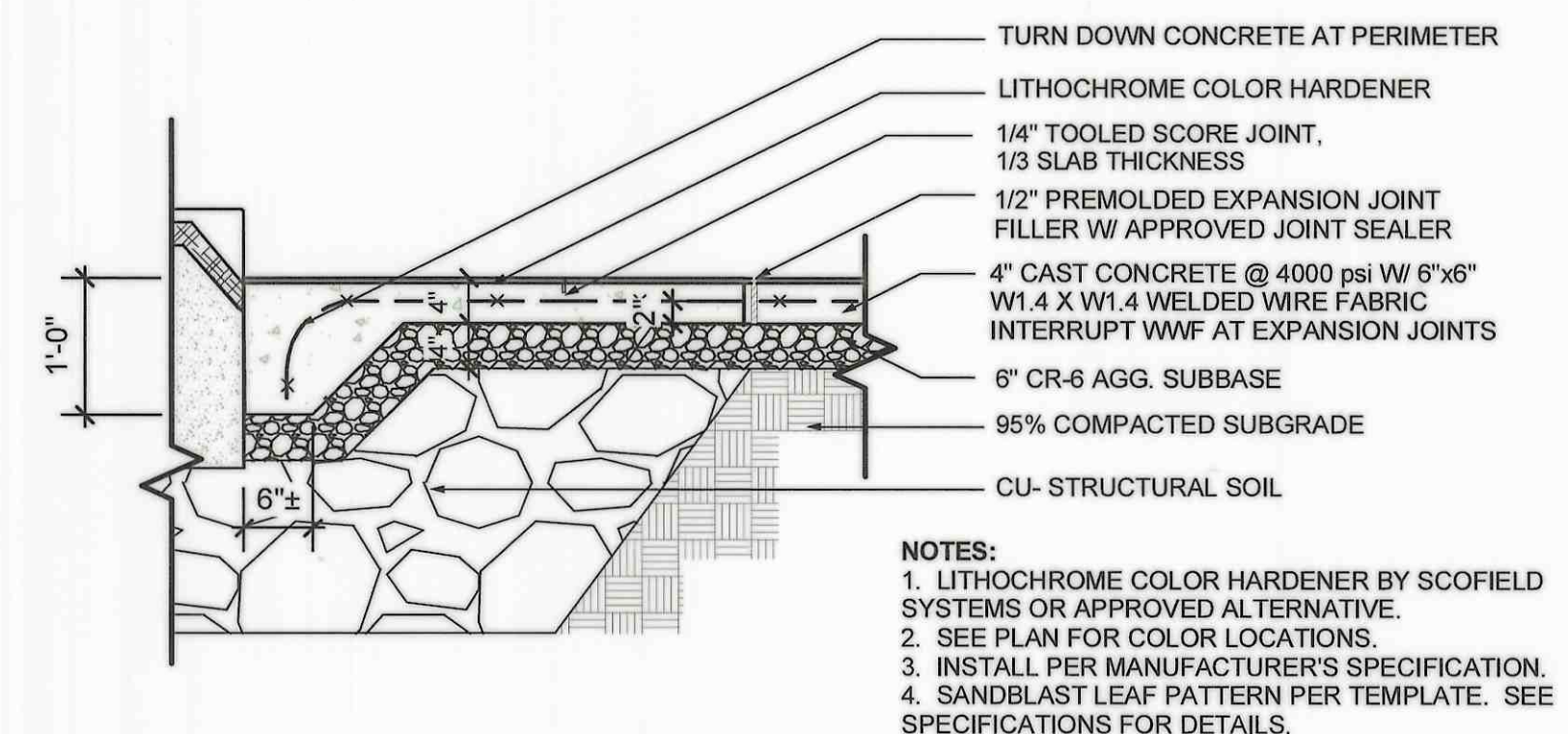

6 Colored Concrete Paving
Scale: 3/4\"/>

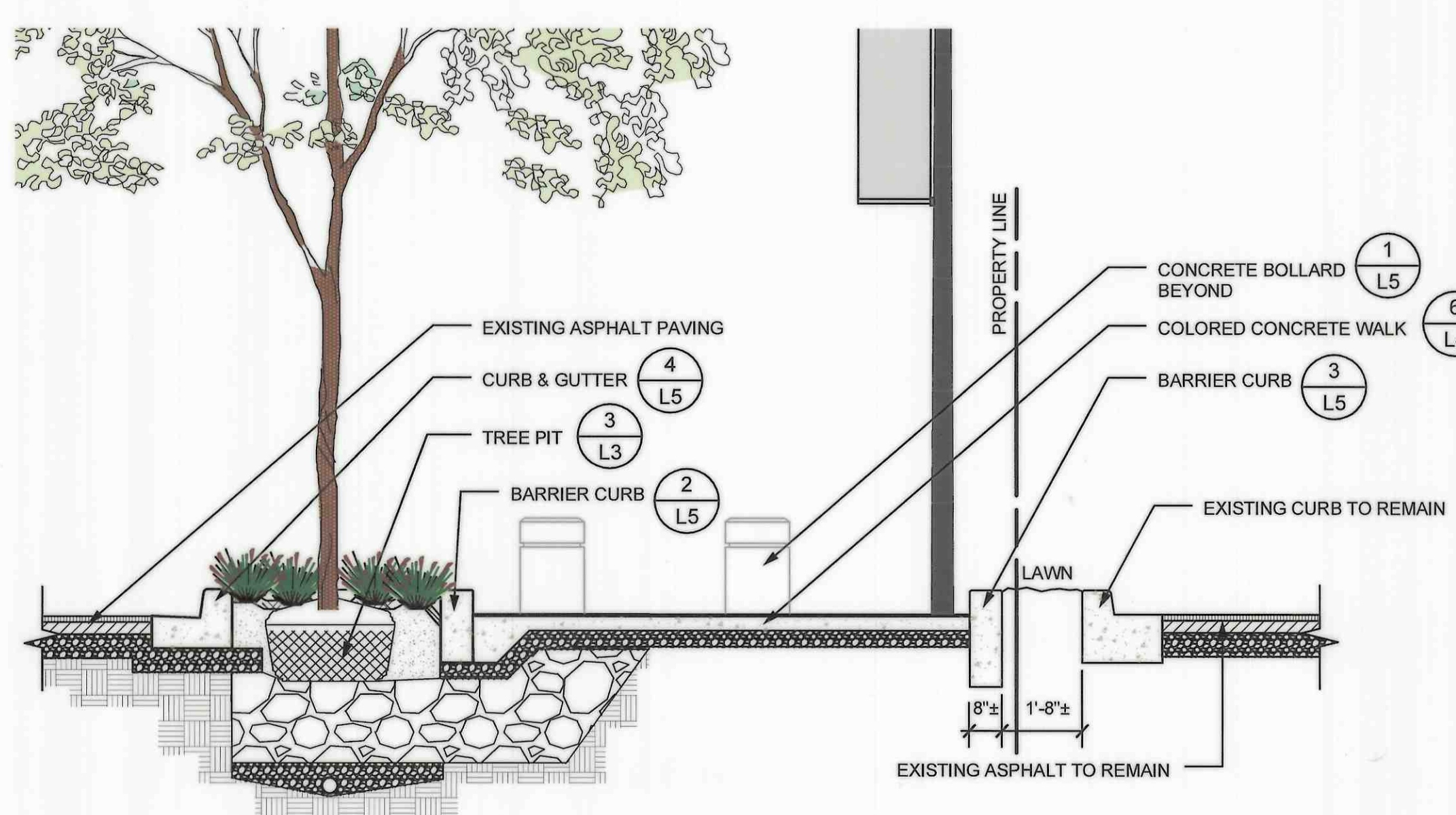

9 Tree Pit Section
Scale: 3/8\"/>

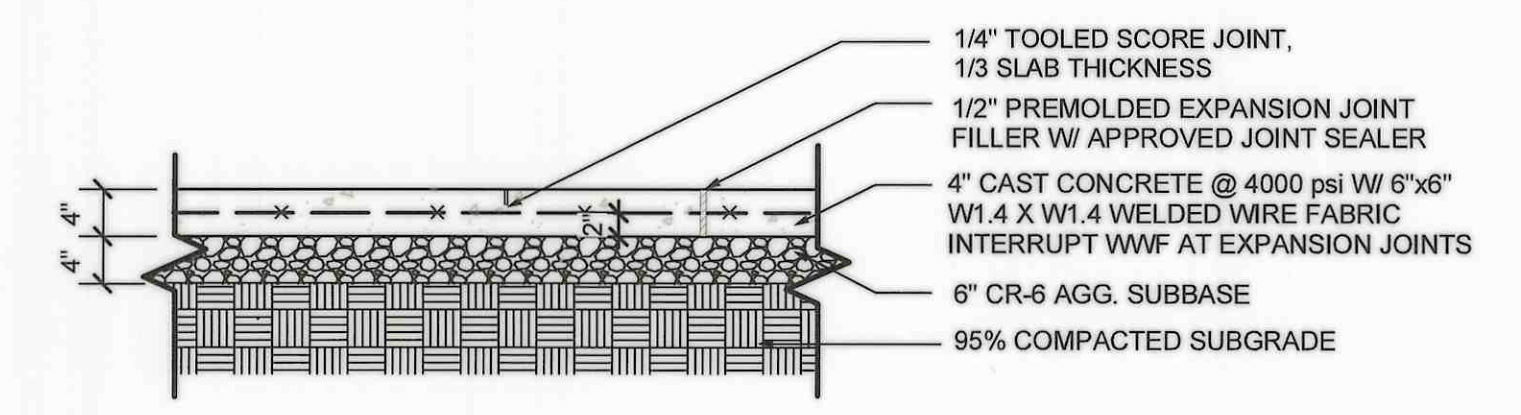

7 Plain Concrete Sidewalk
Scale: 3/4\"/>

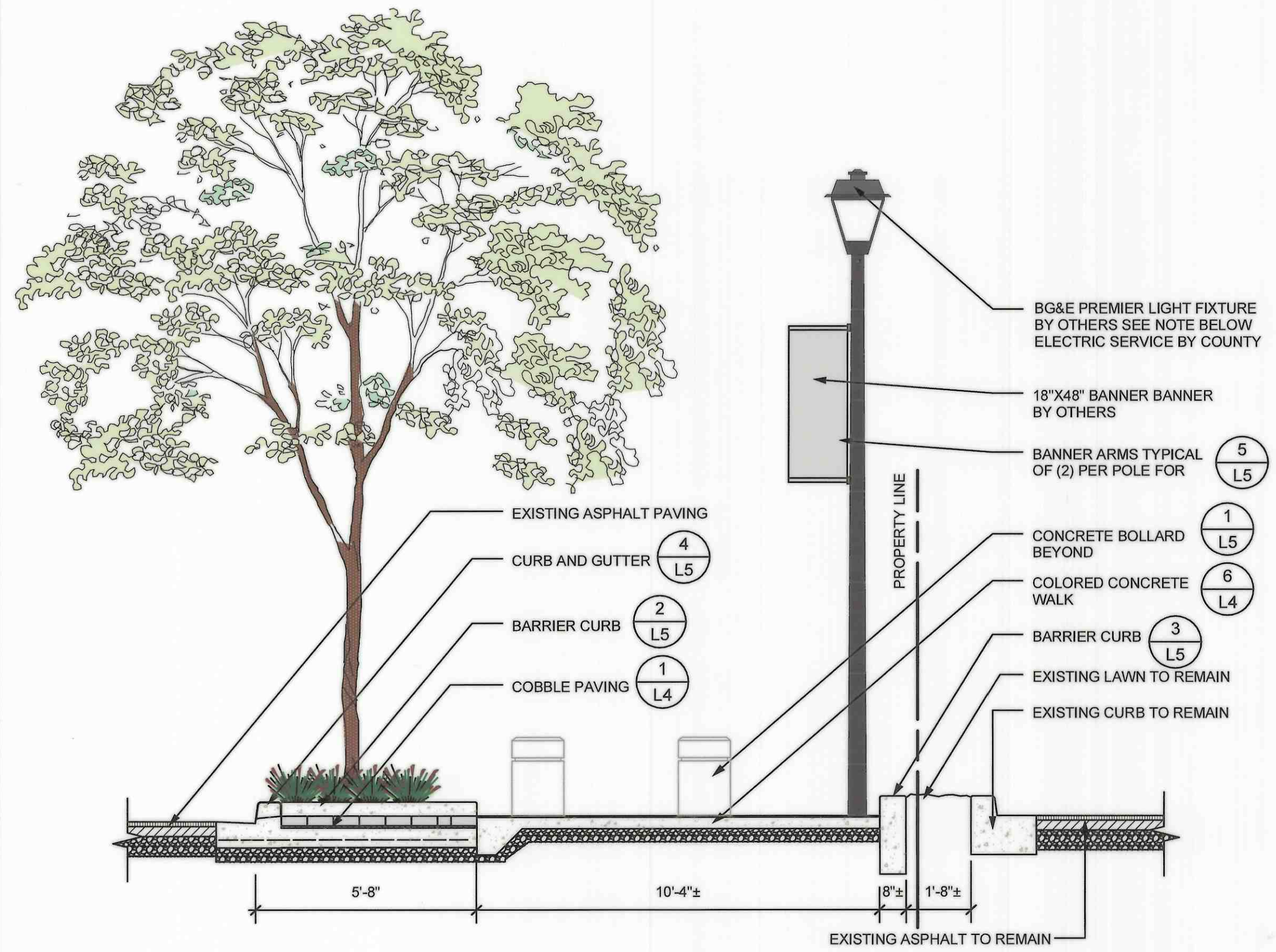

8 Paver Section
Scale: 3/8\"/>

NOTES: ALL LIGHTING IN THE COUNTY RIGHT-OF-WAY TO BE INSTALLED BY BGE ACCORDING TO COUNTY SPECIFICATIONS.

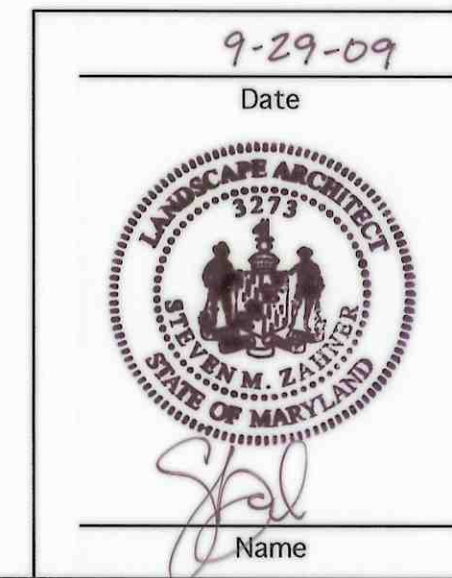

APPROVED: HOWARD COUNTY DEPARTMENT OF PUBLIC WORKS	DATE: 9/29/09	
CHIEF, BUREAU OF ENGINEERING	DATE: 9/29/09	
CHIEF, BUREAU OF HIGHWAYS	DATE: 9-29-09	
DATE	NO.	REVISION

DEPARTMENT OF PUBLIC WORKS
HOWARD COUNTY, MARYLAND

DEPARTMENT OF PLANNING AND ZONING
HOWARD COUNTY, MARYLAND

Robert Oliver Place
DIRECTOR OF PUBLIC WORKS

Robert Oliver Place
DIRECTOR OF PLANNING AND ZONING

SLATER ASSOCIATES, INC.
5560 Sterrett Pl. Suite 302
Columbia, MD 21044
410.992.0212 - fax
410.992.0001 - phone
www.slaterassociates.com
Landscape Architecture • Site Planning • Land Planning

DES:	BY	No.	REVISION	DATE
SMZ	SMZ	1	CONSTRUCTION DOCUMENT REVIEW SUBMISSION	5/19/09
DRN:	SMZ	2	FINAL CONSTRUCTION DOCUMENT SET	9/25/09
CHK:	NHC			
DATE:	9/25/09			

Site Details

Robert Oliver Place - Arts Walk
Oakland Mills Village Center
Robert Oliver Place Columbia, Maryland 21045

SCALE AS SHOWN
SHEET **L4**

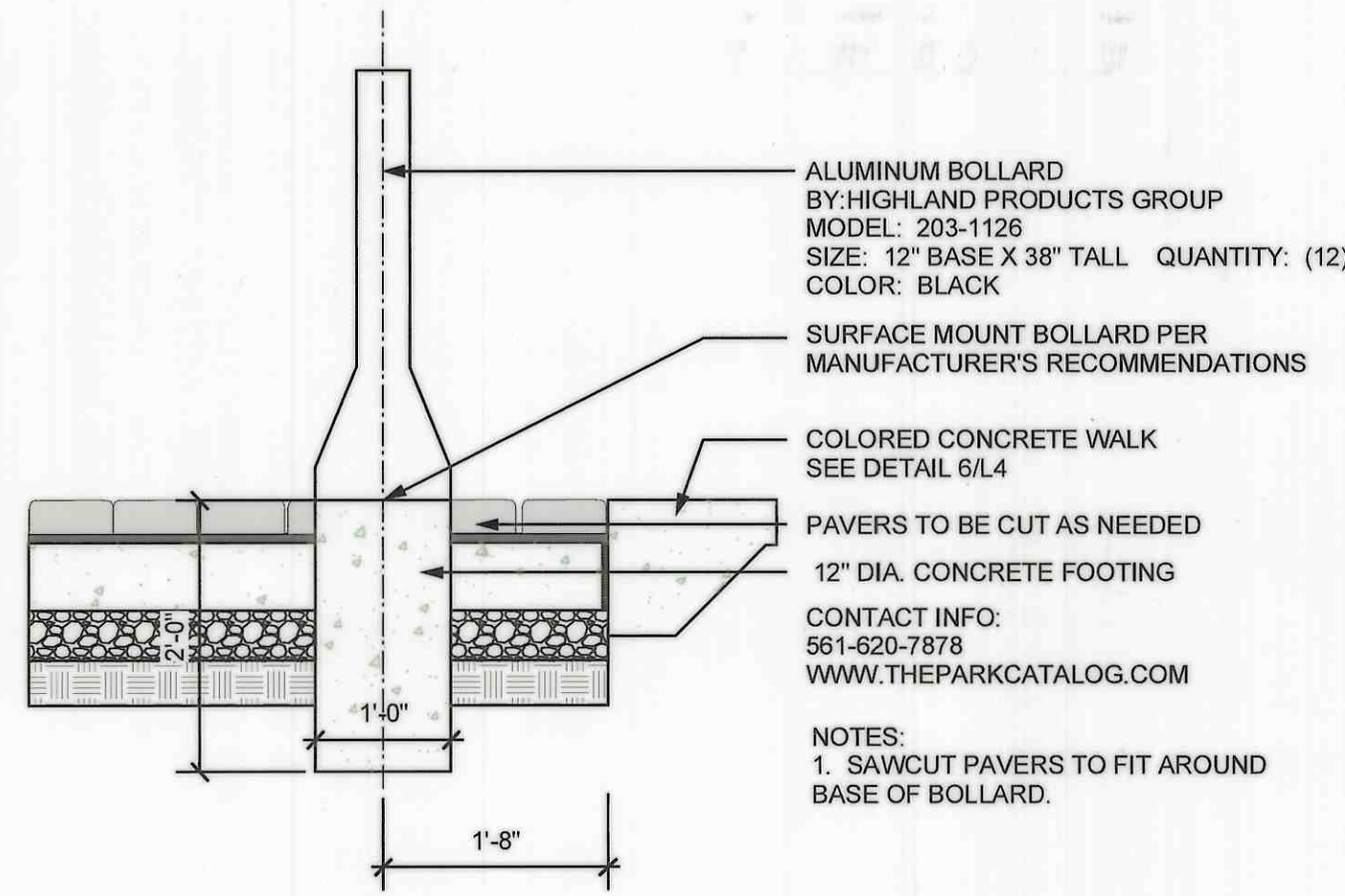

1 Standard Cast Aluminum Bollard
Scale: 3/4" = 1'-0"

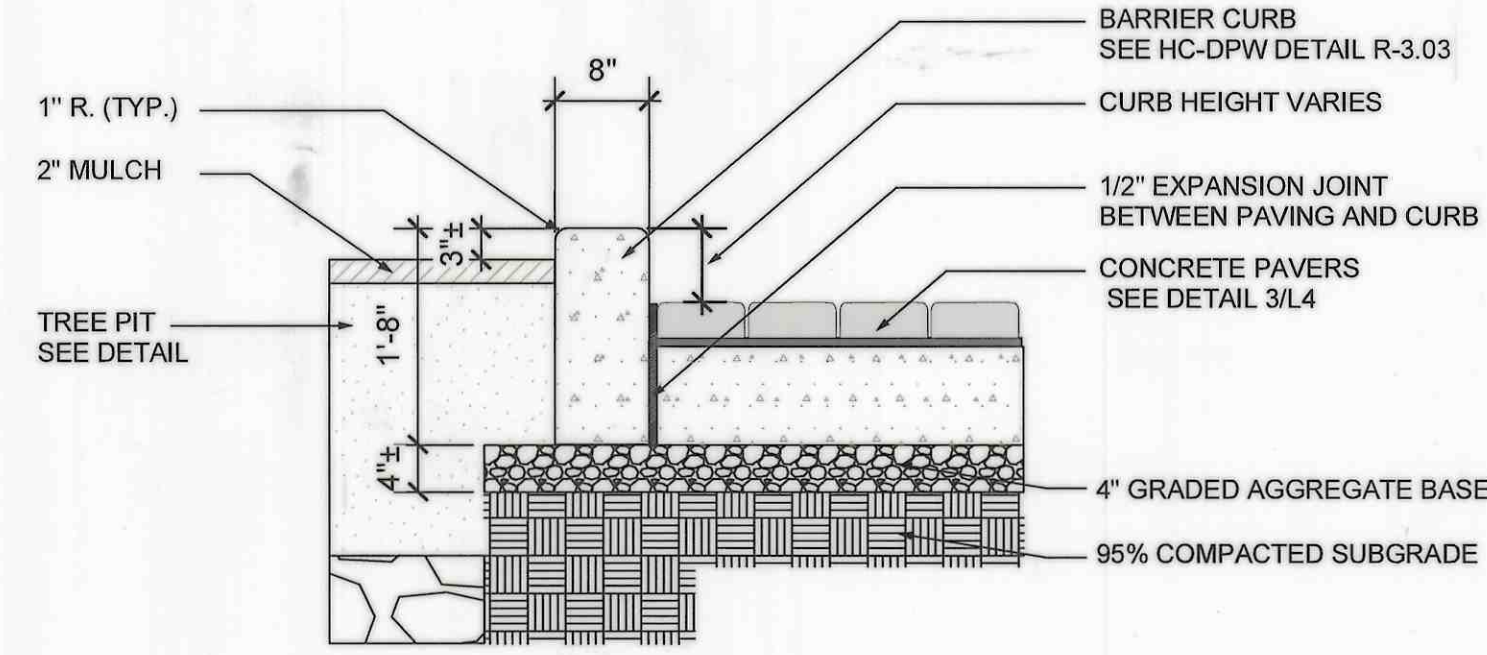

2 Concrete Barrier Curb at Side of Planter
Scale: 3/4" = 1'-0"

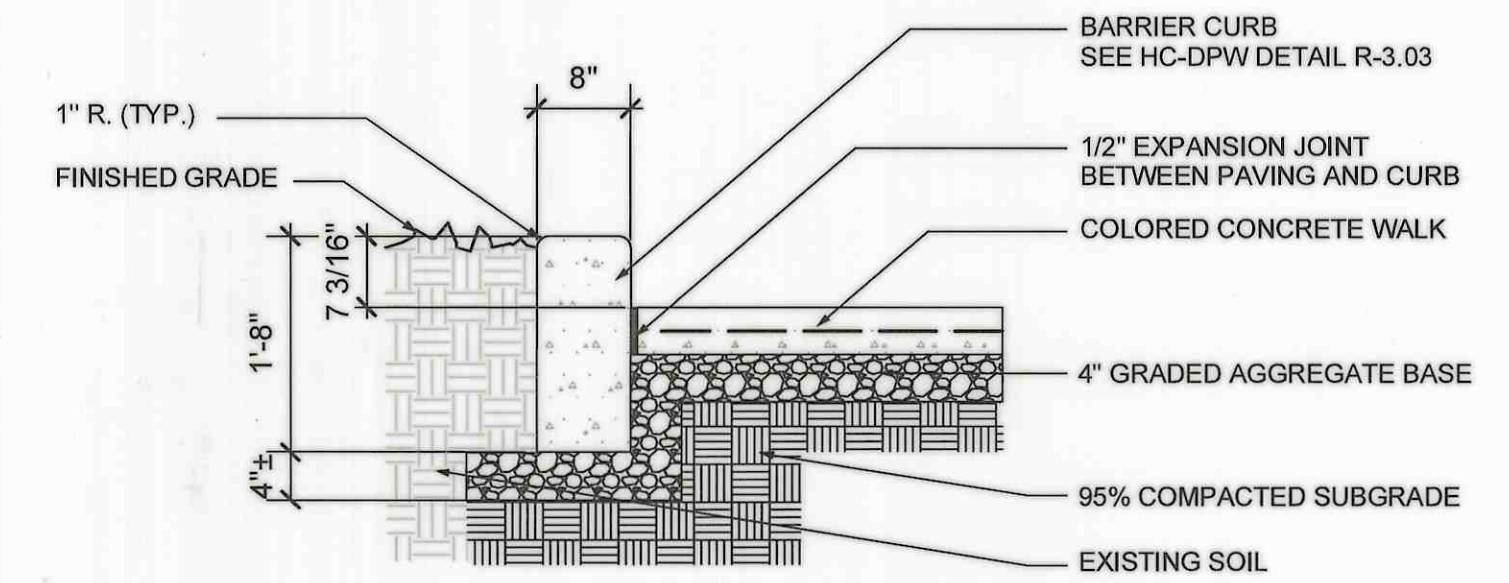

3 Concrete Barrier Curb at Sidewalk
Scale: 3/4" = 1'-0"

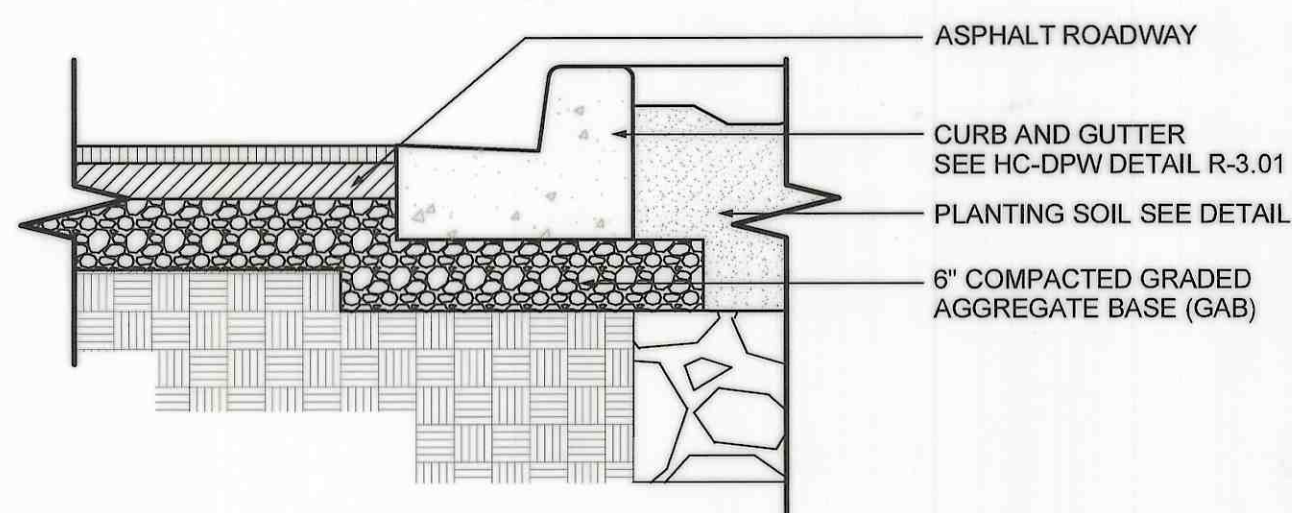

4 Curb And Gutter At Roadway
Scale: 3/4" = 1'-0"



5 Banner Arm Brackets
Scale: 3/4" = 1'-0"

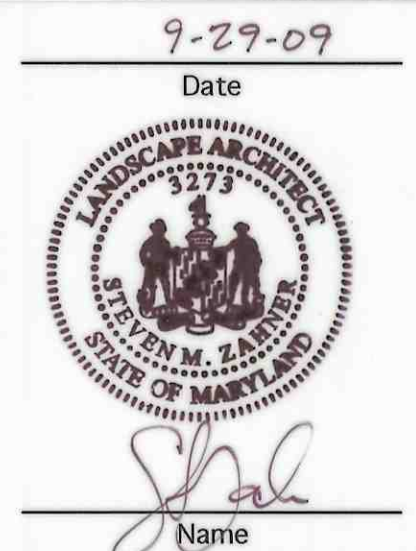

APPROVED: HOWARD COUNTY DEPARTMENT OF PUBLIC WORKS

CHIEF, BUREAU OF ENGINEERING DATE: 9/29/09

CHIEF, BUREAU OF HIGHWAYS DATE: 9-29-09

DATE	NO.	REVISION

DES:	BY	No.	REVISION	DATE
SMZ	SMZ	1	CONSTRUCTION DOCUMENT REVIEW SUBMISSION	5/19/09
DRN:	SMZ	2	FINAL CONSTRUCTION DOCUMENT SET	9/25/09
CHK:	NHC			
DATE:	9/25/09			

Site Details

Robert Oliver Place - Arts Walk
Oakland Mills Village Center
Robert Oliver Place Columbia, Maryland 21045

SCALE
AS
SHOWN
L5

DEPARTMENT OF PUBLIC WORKS
HOWARD COUNTY, MARYLAND

[Signature] 9/25/09
DIRECTOR OF PUBLIC WORKS DATE

DEPARTMENT OF PLANNING AND ZONING
HOWARD COUNTY, MARYLAND

[Signature] 9/25/09
DIRECTOR OF PLANNING AND ZONING DATE

SLATER ASSOCIATES, INC.
5560 Sterrett Pl. Suite 302
Columbia, MD 21044
410.992.0212 - fax
410.992.0001 - phone
www.slaterassociates.com

Landscape Architecture • Site Planning • Land Planning