

# UNDERGROUND WATER STORAGE TANKS FOR FIRE SUPPRESSION

HOWARD COUNTY GOVERNMENT  
DEPARTMENT OF PUBLIC WORKS  
CAPITAL PROJECT NO. F-5972  
CONTRACT NO. 65-4959

## GENERAL NOTES

- THE APPROXIMATE LOCATION OF EXISTING UTILITIES ARE SHOWN. THE CONTRACTOR SHALL TAKE ALL PRECAUTIONS TO PROTECT EXISTING STRUCTURES, UTILITIES AND SERVICES AND MAINTAIN UNINTERRUPTED SERVICE. ANY DAMAGE INCURRED SHALL BE REPAIRED IMMEDIATELY TO THE SATISFACTION OF THE ENGINEER AT THE CONTRACTOR'S EXPENSE.
- TOPOGRAPHIC FIELD SURVEYS WERE PERFORMED IN MAY, 2016 BY KCI TECHNOLOGIES.
- HORIZONTAL AND VERTICAL CONTROL:  
THE COORDINATES SHOWN ON THE DRAWINGS ARE BASED ON MARYLAND STATE REFERENCE SYSTEM NAD'83/91 AS PROJECTED BY HOWARD COUNTY GEODETIC CONTROL STATIONS NO. 22BB, NO. 28AA AND NO. 07FC  
ALL VERTICAL CONTROLS ARE BASED ON NAVD '88, STATIONS 22BB AND 28AA ARE HOWARD COUNTY STANDARD DISKS WITH A PIECE OF IRON TO FACILITATE MAGNETIC DETECTION. STATION 07FC IS A NAIL EMBEDDED ON TOP OF 10" CONCRETE CURB
- THE CONTRACTOR SHALL NOTIFY MISS UTILITY AT 1-800-257-7777 AT LEAST 48 HOURS IN ADVANCE OF ANY WORK IN THIS AREA, SO APPROPRIATE MARKING OF EXISTING UTILITIES CAN BE MADE.
- ALL EXCAVATION SHALL BE KEPT FREE OF WATER UNTIL BACKFILL IS PROPERLY TAMPED IN PLACE TO FINISHED GRADE.
- FOR DETAILS NOT SHOWN ON THE DRAWINGS, AND FOR MATERIALS AND CONSTRUCTION METHODS, USE HOWARD COUNTY DESIGN MANUAL, VOLUME IV, STANDARD SPECIFICATIONS AND DETAILS FOR CONSTRUCTION (LATEST EDITION). THE CONTRACTOR SHALL HAVE A COPY OF VOLUME IV ON THE JOB.
- WHERE TEST PITS HAVE BEEN MADE ON EXISTING UTILITIES, THEY ARE NOTED BY THE SYMBOL  AT THE LOCATION OF THE TEST PIT. A NOTE OR NOTES CONTAINING THE RESULTS OF THE TEST PIT OR PITS IS INCLUDED ON THE DRAWINGS. EXISTING UTILITIES IN THE VICINITY OF THE PROPOSED WORK FOR WHICH TEST PITS HAVE NOT BEEN DUG SHALL BE LOCATED BY THE CONTRACTOR TWO WEEKS IN ADVANCE OF CONSTRUCTION OPERATIONS AT HIS OWN EXPENSE.
- CONTRACTOR SHALL NOTIFY THE FOLLOWING UTILITY COMPANIES OR AGENCIES AT LEAST FIVE WORKING DAYS BEFORE STARTING WORK SHOWN ON THESE PLANS:  

AT&T	1-800-252-1133
BC&E (CONSTRUCTION SERVICES)	410-858-4628
BC&E (EMERGENCY)	410-885-1400
BUREAU OF UTILITIES (DPW)	410-313-4900
COLONIAL PIPELINE CO.	410-795-1390
MISS UTILITY	1-800-257-7777
STATE HIGHWAY ADMINISTRATION	410-531-5533
VERIZON	1-800-743-0033 / 410-224-9210
- TREES AND SHRUBS ARE TO BE PROTECTED FROM DAMAGE TO THE MAXIMUM EXTENT. TREES AND SHRUBS WITHIN THE CONSTRUCTION AREA ARE NOT TO BE REMOVED UNLESS THEY ARE LOCATED WITHIN THE AREA OF EXCAVATION.
- CLEAR ALL UTILITIES BY A MINIMUM OF 12". CLEAR ALL POLES BY 5'-0" MINIMUM. THE CONTRACTOR SHALL CONTACT THE UTILITY COMPANIES AND MAKE ARRANGEMENTS FOR BRACING OF POLES AS REQUIRED.

## TANK GENERAL NOTES:

- CONSTRUCTION SHALL BE COMPLETED IN ACCORDANCE WITH THESE DRAWINGS, THE SPECIAL PROVISIONS AND THE HOWARD COUNTY STANDARD DETAILS AND SPECIFICATIONS FOR CONSTRUCTION.
- THE CONTRACTOR SHALL CONDUCT A VERIFICATION OF SITE STAKING AND LAYOUT PRIOR TO EXCAVATION.
- ALL EXCAVATION, BACKFILL, AND COVER SHALL BE PERFORMED IN ACCORDANCE WITH THE SPECIFICATIONS ON THESE DRAWINGS AS A MINIMUM, AND TANK MANUFACTURER'S SPECIFICATIONS. DETAILS AND DIMENSIONS SHALL NOT SUPERCEDE MANUFACTURER'S REQUIREMENTS. EXCAVATION DEPTH SHALL BE DETERMINED BY SITE CONDITIONS AND MANUFACTURER'S SPECIFICATIONS. SHORE AS NECESSARY. ELEVATIONS SHOWN IN TABLE 2 ON SHEET 5 OF 7 REPRESENT THE MAXIMUM ALLOWABLE CONDITION FOR PROPER TANK OPERATION AND SHALL NOT BE EXCEEDED.
- ALL TESTING IS THE RESPONSIBILITY OF THE CONTRACTOR.
- ALL CONTRACTORS SHALL BE CERTIFIED BY THE TANK MANUFACTURER PRIOR TO ANY INSTALLATION
- ALL WORK SHALL BE COMPLETED IN A TIMELY AND WORKMANLIKE MANNER. ALL WORK SHALL CONFORM TO APPLICABLE CODES AND STANDARDS.
- EXCAVATION AND SITE WORK SHALL BE PERFORMED IN ACCORDANCE WITH APPLICABLE AND CURRENT MSHA AND OSHA REGULATIONS.
- PRESSURE TEST SHALL BE PERFORMED BY THE INSTALLER PRIOR TO AND AFTER INSTALLATION, IN ACCORDANCE WITH THE MANUFACTURER'S SPECIFICATIONS AND THESE DRAWINGS.
- AN OPERATIONAL TEST SHALL BE CONDUCTED AFTER INSTALLATION PER THE TANK MANUFACTURERS SPECIFICATIONS AND THESE DRAWINGS.
- ALL STEEL AND PVC FITTINGS ABOVE GRADE SHALL BE PAINTED WITH EXTERIOR ENAMEL, UNLESS OTHERWISE SPECIFIED. COLORS SHALL BE APWA STANDARD YELLOW OR RED AS NOTED ON THE DRAWINGS.
- THE CONTRACTOR SHALL RESTORE THE SITE TO ORIGINAL CONDITION AFTER FINAL TESTING INCLUDING, BUT NOT LIMITED TO FINE GRADING, SEEDING, MULCHING, AND GENERAL CLEANUP.
- THE DISTANCE FROM THE CENTERLINE OF THE DRAFT FITTING SHALL BE 8'-0" OR LESS TO THE EDGE OF THE ROADWAY OR PULLOFF. THIS DIMENSION SHALL APPLY TO ALL INSTALLATION CONFIGURATIONS.
- THE WATER LEVEL INDICATOR SHALL BE ORIENTED TOWARD THE ACCESS AREA OR PULLOFF FOR VISIBILITY.
- INSTALL POST AND DOT R7 STYLE NO PARKING SIGNAGE, SEE SHEET 5 OF 7 FOR DETAILS. TOP OF POST SHALL BE 7'-0" ABOVE FINISHED GRADE.
- UNLESS OTHERWISE NOTED, THE CENTER DRAFT CONFIGURATION SHALL BE USED WHERE THE TANK IS PLACED PARALLEL TO THE PULLOFF OR ROADWAY. THE END DRAFT CONFIGURATION SHALL BE USED WHERE THE TANK IS PLACED PERPENDICULAR TO THE PULLOFF OR ROADWAY. ALTERNATE CONFIGURATIONS MAY BE REQUIRED DUE TO SPECIFIC SITE CONDITIONS.
- VARIATION IN FITTING PLACEMENT DUE TO DIFFERENT TANK MANUFACTURERS IS ACCEPTABLE, BUT CRITICAL DIMENSIONS SHALL BE MAINTAINED, SEE SPECIFICATIONS, VARIATIONS OR SPECIAL FEATURES REQUIRE APPROVAL BY THE OWNER AND THE HOWARD COUNTY FIRE MARSHALL.

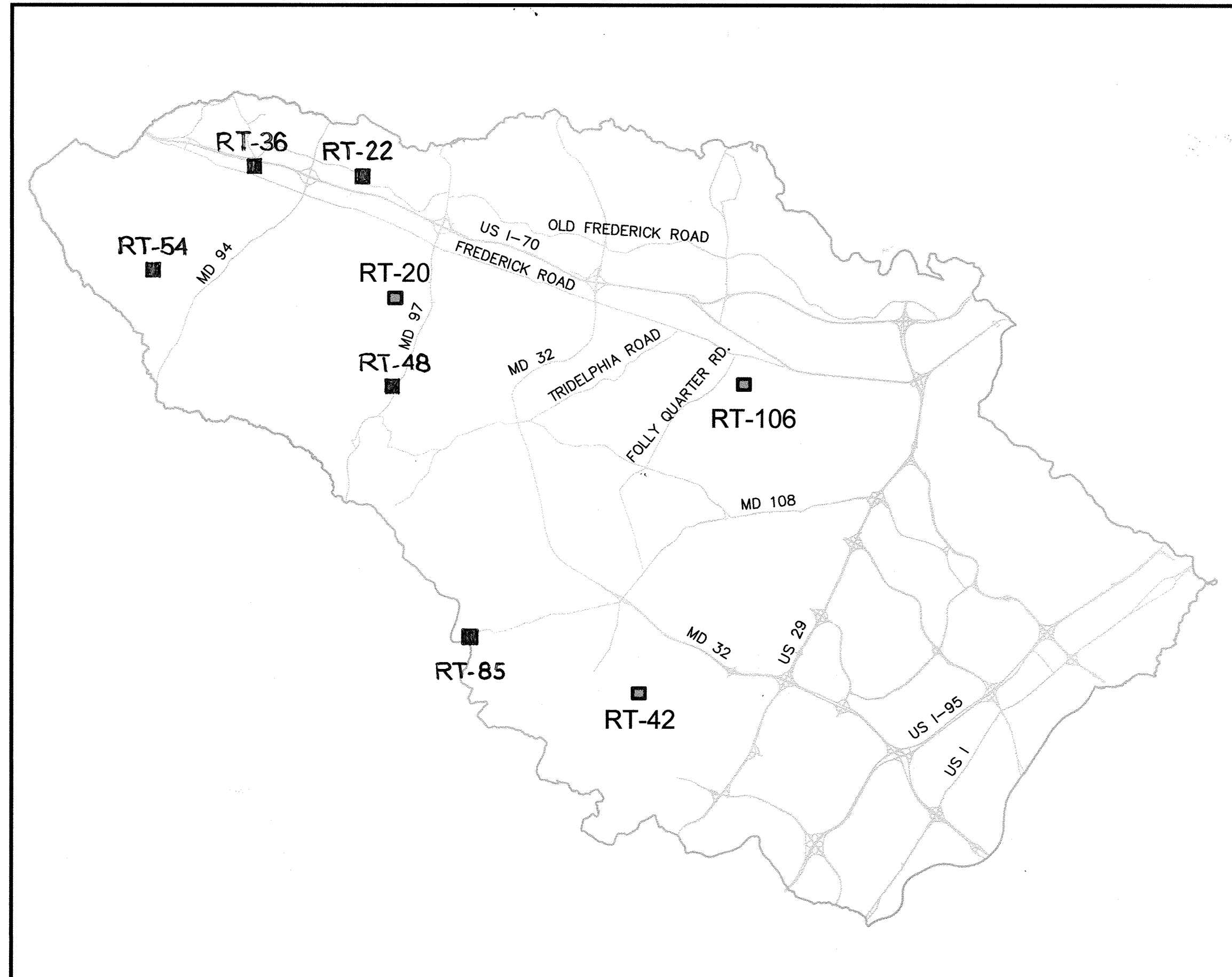

HOWARD COUNTY, MARYLAND  
SCALE: 1" = 12,000'

INDEX OF SHEETS	
SHEET NO.	DESCRIPTION
1 of 7	TITLE SHEET
2 of 7	SPECIFICATIONS - 1
3 of 7	SPECIFICATIONS - 2
4 of 7	GENERAL DETAILS - 1
5 of 7	GENERAL DETAILS - 2
6 of 7	GENERAL DETAILS - 3
7 of 7	SEDIMENT AND EROSION CONTROL NOTES AND DETAILS
RT-20	CARRS MILL RD. AT WESTERN REGIONAL PARK
RT-42	SIMPSON RD. AT HALL SHOP RD.
RT-106	DOUGHREGAN MANOR

### ENGINEER'S CERTIFICATION

"I/WE CERTIFY THAT THIS PLAN FOR EROSION AND SEDIMENT CONTROL REPRESENTS A PRACTICAL AND WORKABLE PLAN BASED ON MY PERSONAL KNOWLEDGE OF THE SITE CONDITIONS AND IT WAS PREPARED IN ACCORDANCE WITH THE REQUIREMENTS OF THE HOWARD SOIL CONSERVATION DISTRICT.

  
 GUOHUA WANG  
 KCI TECHNOLOGIES  
 936 RIDGEBROOK RD  
 SPARKS, MARYLAND 21152  
 DATE: 7/10/2017

### OWNERS / DEVELOPER'S CERTIFICATION

"I/WE CERTIFY THAT ALL CLEARING, GRADING, CONSTRUCTION OR DEVELOPMENT WILL BE DONE PURSUANT TO THE PLAN AND THAT A RESPONSIBLE PERSON INVOLVED IN THE CONSTRUCTION PROJECT WILL HAVE, BEFORE BEGINNING THE PROJECT, A CERTIFICATION OF TRAINING AT A PROGRAM APPROVED BY THE MARYLAND DEPARTMENT OF THE ENVIRONMENT FOR THE CONTROL OF SEDIMENT AND EROSION. I ALSO AUTHORIZE PERIODIC ON-SITE INSPECTION BY THE HOWARD SOIL CONSERVATION DISTRICT.

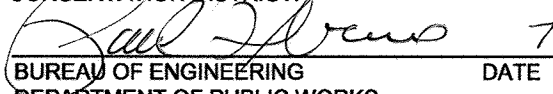

  
 BUREAU OF ENGINEERING  
 DEPARTMENT OF PUBLIC WORKS  
 DATE: 7.17.17

NOTE:  
EACH TANK SITE SHALL BE CONTROLLED IN ACCORDANCE WITH THE HOWARD SOIL CONSERVATION DISTRICT "STANDARD EROSION AND SEDIMENT CONTROL PLAN FOR MINOR EARTH DISTURBANCE", AND ADHERE TO THE LIMITATIONS, CONDITIONS AND REQUIREMENTS THEREIN. A COPY OF THE STANDARD PLAN SHALL BE ON-SITE FOR REFERENCE DURING WORKING HOURS.

PROFESSIONAL CERTIFICATION: I hereby certify that these documents were prepared or approved by me, and that I am a duly licensed professional engineer under the laws of the State of Maryland, License No. 31363. Expiration Date 01/16/2018.

KCI TECHNOLOGIES PROJECT NO.: 13122677\_38

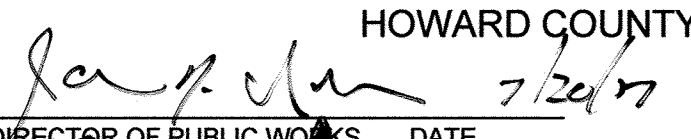
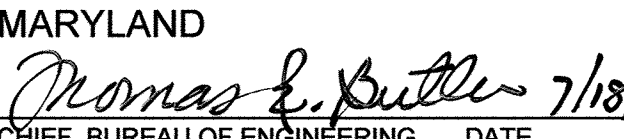
JUL 10, 2017 - 4:28pm User: hmc\jwh\jwh Title: SHEET\_RT-20-42\_108.dwg

DEPARTMENT OF PUBLIC WORKS HOWARD COUNTY, MARYLAND	
 DIRECTOR OF PUBLIC WORKS DATE: 7/20/17	 CHIEF, BUREAU OF ENGINEERING DATE: 7/18/17
 CHIEF, BUREAU OF UTILITIES DATE: 7/20/17	 CHIEF, UTILITY DESIGN DIVISION DATE: 7/14/17

**KCI TECHNOLOGIES**  
 936 Ridgbrook Road  
 Sparks, MD 21152  
 Phone: (410) 316-7800  
 Fax: (410) 316-7817  
 www.kci.com

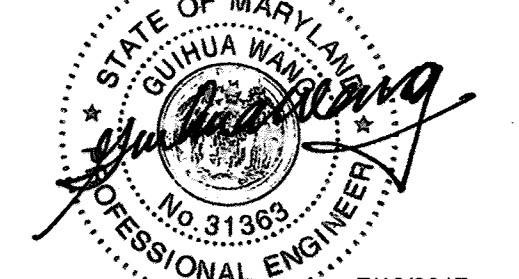
  
 GUOHUA WANG  
 PROFESSIONAL ENGINEER  
 LICENSE NO. 31363  
 EXPIRES 01/16/2018  
 7/10/2017

DES:	KFJ				
DRN:	KFJ				
CHK:	GW				
DATE:	JULY, 2017	BY	NO.	REVISION	DATE

TITLE SHEET

**UNDERGROUND WATER STORAGE TANKS FOR FIRE SUPPRESSION**  
 CAPITAL PROJECT No. F-5972  
 CONTRACT No. 65-4959  
 HOWARD COUNTY, MARYLAND

SCALE AS SHOWN  
 SHEET 1 OF 7

SPECIFICATIONS FOR UNDERGROUND WATER STORAGE TANKS FOR FIRE PROTECTION

1. INTRODUCTION

1.1. SCOPE

THE CONSTRUCTION OF UNDERGROUND TANKS FOR FIRE PROTECTION IN ACCORDANCE WITH HOWARD COUNTY CODE, TITLE 17 AND THIS SPECIFICATION IS PART OF A PROGRAM DESIGNED TO IMPROVE THE LEVEL OF PROTECTION FROM FIRES IN RESIDENTIAL AND COMMERCIAL PROPERTIES. THESE SPECIFICATIONS, ALONG WITH ASSOCIATED DOCUMENTS, PROVIDE THE INFORMATION NECESSARY FOR THE CONSTRUCTION AND PLACEMENT OF FIRE PROTECTION TANKS USED FOR THIS PURPOSE.

1.2. PURPOSE

THE PURPOSE OF THIS SPECIFICATION IS TO PROVIDE THE TECHNICAL INFORMATION REQUIRED FOR THE CONSTRUCTION OF UNDERGROUND WATER STORAGE TANKS IN ACCORDANCE WITH HOWARD COUNTY MARYLAND, TITLE 17 AND ALL DATA THEREIN REFERENCED.

2. UNDERGROUND TANKS

2.1. MATERIALS FOR A STATIC WATER SUPPLY TANK

- 2.1.1. TANKS SHALL BE CONSTRUCTED OF SINGLE-WALL FIBERGLASS PER THESE SPECIFICATIONS AND IN ACCORDANCE WITH THE APPROVED MANUFACTURER'S SPECIFICATIONS.
2.1.2. THE MANUFACTURER SHALL PROVIDE A 30-YEAR WARRANTY, AGAINST DEFECTS IN MATERIAL FOR THE TANK SYSTEM, TO THE PURCHASER OF THE TANK AND THEIR HEIRS, SUCCESSORS, AND ASSIGNS.

2.2. FEATURES

- 2.2.1. THE TANK SYSTEM SHALL INCLUDE A DEVICE FOR HOLDING THE TANK IN POSITION AGAINST FLOATATION (DEADMAN). THIS CONFIGURATION SHALL BE SUPPLIED BY THE TANK MANUFACTURER AS PART OF THE TANK PACKAGE.
2.2.2. THE TANK SHALL INCLUDE A REMOVABLE ACCESS COVER AT GRADE (MANHOLE), AT LEAST 52" IN DIAMETER, TO ALLOW ENTRY FOR MAINTENANCE AND INSPECTION OF THE INSIDE OF THE TANK.
2.2.3. A PAD CONSISTING OF 6 INCH THICK CONCRETE SHALL BE PLACED OVER THE TANK, AND SHALL ENCOMPASS ALL FITTINGS. REFER TO TANK DRAWINGS FOR CONCRETE SPECIFICATIONS.

2.2.4. FITTINGS

- 2.2.4.1. ONE DRAFT CONNECTION SHALL CONSIST OF A 6 INCH NOMINAL DIAMETER DUCTILE IRON PIPE. THE DRAFT CONNECTION SHALL TERMINATE IN A 6NH (NATIONAL HYDRANT FEMALE) SWIVEL CONNECTOR WITH PLUG OR CAP.
2.2.4.2. ONE COMBINATION VENT/FILL INDICATOR SHALL CONSIST OF AN 8 INCH DIAMETER PVC PIPE WHICH ALLOWS VISUAL INSPECTION OF THE TANK WATER LEVEL, AS WELL AS PROVIDING THE REQUIRED AMOUNT OF VENTING TO THE TANK.

- 2.2.4.3. ONE FILL CONNECTION SHALL CONSIST OF A 4 INCH NOMINAL DIAMETER DUCTILE IRON PIPE, WITH A SIAMISE CONNECTION WITH TWO, TWO AND ONE HALF INCH (2- 1/2 ") CONNECTION AND ONE 4" STORTZ CONNECTION.
2.2.4.4. ALL PIPE JOINTS ABOVE THE SLAB SHALL BE FLANGED BREAK AWAY CONNECTIONS AT OR NEAR SLAB.

2.2.5. SUBMITTALS

- 2.2.5.1. SHOP DRAWINGS SHALL BE PROVIDED FOR ALL MATERIALS OR COMPONENTS OF CONSTRUCTION, AND PROPOSED PIPING LAYOUTS.
2.2.5.2. IN THE EVENT THAT SITE CONDITIONS DICTATE THE USE OF STRUCTURAL ELEMENTS NOT EXPLICITLY DETAILED IN THE DRAWINGS, THE CONTRACTOR SHALL SUBMIT DRAWINGS AND CALCULATIONS SIGNED AND SEALED BY A STRUCTURAL ENGINEER LICENSED IN THE STATE OF MARYLAND.
2.2.5.3. OPERATION AND MAINTENANCE MANUALS SHALL BE PROVIDED BY THE TANK MANUFACTURER, INCLUDING OPERATIONAL TESTING PROCEDURES.

- 2.2.6. ANY FEATURES NOT INCLUDED IN THIS SPECIFICATION, AS WELL AS ANY SPECIAL CIRCUMSTANCES SUCH AS MULTIPLE-TANK DESIGNS SHALL BE EVALUATED AND APPROVED DURING DESIGN PHASE AND BEFORE ANY CONSTRUCTION IS STARTED.

- 2.2.7. THE STANDARD TANK DETAIL, 30,000 GALLON TANK FIRE SUPPRESSION WATER STORAGE, ON SHEET 4 OF 6, DEFINES THE REQUIREMENTS FOR A TYPICAL 30,000 GALLON, 10-FOOT DIAMETER TANK INSTALLATION. TANK SIZES OTHER THAN 30,000 GALLONS MAY REQUIRE ADDITIONAL DRAWINGS TO BE PROVIDED TO FIT THE REQUIREMENTS OF A PARTICULAR SITE.

2.3. INSTALLATION

- 2.3.1. ALL TANKS SHALL BE INSTALLED IN ACCORDANCE WITH THESE SPECIFICATIONS AND THE APPROVED MANUFACTURER'S SPECIFICATIONS.
2.3.2. LOCATION AND ORIENTATION OF THE TANK SHALL BE DETERMINED DURING SITE PLAN OR PRELIMINARY SUBDIVISION PLAN LAYOUT, AS APPROVED BY THE HOWARD COUNTY FIRE OFFICIAL.
2.3.3. THE INSTALLING CONTRACTOR SHALL BE RESPONSIBLE FOR OBTAINING ALL NECESSARY PERMITS FOR WORK AND FOR SCHEDULING REQUIRED INSPECTIONS.

2.3.4. THE FITTINGS SHALL BE PLACED AS FOLLOWS:

- 2.3.4.1. THE DRAFT CONNECTION SHALL BE LOCATED 8 FEET OR LESS FROM THE EDGE OF THE PARKING SURFACE OR CURB LINE. THIS ALLOWS FOR ONE 10 FOOT SECTION OF SUCTION SLEEVE TO BE USED FOR DRAFTING.
2.3.4.2. TOTAL ELEVATION FROM THE BOTTOM OF THE SUCTION PIPE TO THE CENTERLINE OF THE DRAFT CONNECTION SHALL NOT EXCEED 15 FEET ZERO INCHES.
2.3.4.3. THE DRAFT CONNECTION SHALL BE FIXED AT A HEIGHT OF 18 INCHES ABOVE FINISHED GRADE OF THE PULL OFF PAD, TO THE CENTERLINE OF THE FITTING.
2.3.4.4. THE FILL CONNECTION SHALL BE FIXED AT A HEIGHT OF 18 INCHES ABOVE FINISHED GRADE OF THE PULL OFF PAD, TO THE CENTERLINE OF THE FITTING.

- 2.3.5. EXCAVATION SHALL BE PERFORMED PER ALL APPLICABLE REGULATIONS. THE EXCAVATION SHALL BE BACKFILLED WITH A MATERIAL PER HOWARD COUNTY SPECIFICATIONS. IN DESIGNS IN WHICH THE DRAFT PIPE IS PLACED ON THE TANK END, THE TANK SHALL HAVE A 2 PERCENT SLOPE TOWARD THE DRAFT CONNECTION END.

2.4. TESTING AND ACCEPTANCE

- 2.4.1. THE TANK SHALL BE OPERABLE WITH A RATE OF FLOW (FIRE FLOW) OF 1000 GALLONS PER MINUTE (GPM) MINIMUM USING A FIRE DEPARTMENT PUMPER OPERATING UNDER NORMAL CONDITIONS.
2.4.2. A PRESSURE TEST SHALL BE PERFORMED PRIOR TO INSTALLATION OF THE TANK, PER THESE SPECIFICATIONS AND THE APPROVED MANUFACTURER'S SPECIFICATIONS.
2.4.3. A PRESSURE TEST SHALL BE PERFORMED PRIOR TO INSTALLATION AT A MAXIMUM PRESSURE OF 5 PSI (POUNDS PER SQUARE INCH) AND HELD FOR A TIME PERIOD AS DETERMINED BY THE HOWARD COUNTY FIRE OFFICIAL, OR PER MANUFACTURER'S SPECIFICATIONS, WHICHEVER IS MORE STRINGENT.
2.4.4. AN OPERATIONAL TEST SHALL BE PERFORMED WHEN CONSTRUCTION IS COMPLETED, IN ACCORDANCE WITH THE APPROVED PROCEDURES.
2.4.5. FINAL APPROVAL WILL BE MADE PER NOTIFICATION IN WRITING BY THE HOWARD COUNTY FIRE OFFICIAL.

2.5. ACCESSIBILITY AND SURROUNDING FEATURES

- 2.5.1. A PULLOFF SHALL BE CONSTRUCTED AS SHOWN ON THE DRAWINGS. THE REQUIREMENTS FOR EACH SITE WILL BE EVALUATED AND APPROVED BY THE FIRE OFFICIAL PRIOR TO START OF WORK.
2.5.2. NO OBSTRUCTIONS SHALL IMPEDE ACCESS TO TANK FITTINGS.
2.5.2.1. LANDSCAPING, BRUSH, AND TREES SHALL BE TRIMMED AWAY FROM FITTINGS. OVERHANGING BRANCHES SHALL BE TRIMMED AWAY AT A MINIMUM OF 12 FEET OVERHEAD.
2.5.3. PROTECTIVE DEVICES SHALL BE USED AS APPLICABLE TO PREVENT DAMAGE TO THE FITTINGS AND TO PROVIDE SAFETY TO OPERATORS.
2.5.4. A REFLECTIVE SIGN SHALL BE POSTED WHICH CLEARLY INDICATES TANK FULL CAPACITY AND IDENTIFICATION (ID) NUMBER.
2.5.5. AN APPROVED NO PARKING SIGN SHALL BE PROVIDED AND ATTACHED TO A METAL POST AT EACH END OF THE PULL-OFF AREA.
2.5.6. ALL FITTINGS ABOVE GRADE SHALL BE PAINTED WITH EXTERIOR-GRADE ENAMEL.
A. BOLLARDS
B. GUARD RAILS
C. FENCING
D. WALKWAYS
E. CURBS
F. ANY OTHER BARRIERS/DEVICES AS DETERMINED BY THE FIRE OFFICIAL

3. REFERENCES

3.1. PUBLISHED STANDARDS

- 3.1.1. NFPA 1963 - STANDARD FOR FIRE HOSE SCREW THREADS
3.1.2. NFPA 1142 - STANDARD FOR WATER SUPPLIES FOR SUBURBAN AND RURAL FIRE PROTECTION
3.1.3. NFPA 1141 - STANDARD FOR FIRE PROTECTION IN PLANNED BUILDING GROUPS
3.1.4. ASTM C33

3.2. OTHER REFERENCED DOCUMENTS

- 3.2.1. THE CODE OF PUBLIC LOCAL LAWS AND ORDINANCES OF HOWARD COUNTY MARYLAND, CHAPTER 112.
3.2.2. UNDERGROUND TANKS & DRY FIRE HYDRANTS MAINTENANCE AND INSPECTION, CHIEF GREG DODS / REGIONAL FIRE PROTECTION COMMITTEE, 2003.

4. PREPARATION FOR INSTALLATION

- 4.1. THE TANK INSTALLER SHALL TAKE CARE SO THAT THE TANK IS NOT DROPPED OR DAMAGED DURING DELIVERY, UNLOADING AND HANDLING ON THE JOB SITE.
4.2. BEFORE UNLOADING THE TANK FROM THE TRUCK, THE TANK INSTALLER SHALL MAKE SURE THAT ALL TOOLS OR OTHER ITEMS THAT MAY DAMAGE THE TANK DURING UNLOADING ARE REMOVED FROM THE TRAILER BED.
4.3. BEFORE THE TANK IS UNLOADED OR RELOCATED ON THE JOB SITE (AND BEFORE REINSTALLATION TESTING AT JOB SITE), THE TANK INSTALLER SHALL COMPLETE THE FOLLOWING STEPS:
4.3.1. VISUALLY INSPECT THE ENTIRE EXTERIOR SURFACE OF THE TANK TO MAKE SURE THAT NO SHIPPING OR HANDLING DAMAGE HAS OCCURRED.
4.3.2. BE SURE THAT ALL EQUIPMENT USED TO LIFT THE TANK IS RATED TO HANDLE THE LOAD.
4.3.3. TO UNLOAD TANKS, USE THE LIFTING LUGS THAT ARE SITUATED ON TOP OF THE TANK IN ITS ROTATED POSITION.
4.3.4. DO NOT WRAP CHAIN OR CABLE AROUND THE TANK.
4.3.5. USE GUY ROPES TO GUIDE THE TANK WHEN NEEDED.
4.3.6. DO NOT ROLL THE TANK TO MOVE IT.
4.4. WHENEVER A TANK IS TEMPORARILY PLACED ABOVEGROUND AT THE SITE, CHOCK IT IN PLACE TO PREVENT ROLLING.
4.5. WHENEVER A TANK IS TEMPORARILY PLACED ABOVE THE GROUND AT THE SITE, ALWAYS TAKE EXTRA CARE SO WATER DOES NOT ENTER THE COLLAR.

5. PRE-INSTALLATION TESTING

- 5.1. PRIOR TO ANY INSTALLATION IT IS THE REQUIREMENT OF THE CONTRACTOR TO MEET OR OBTAIN ALL CERTIFICATION REQUIRED BY THE TANK MANUFACTURER.
5.2. TANK MUST BE RETESTED AT THE SITE PRIOR TO INSTALLATION IN ORDER TO VERIFY THE ABSENCE OF SHIPPING AND HANDLING DAMAGE.
5.3. THE INSTALLER SHALL VERIFY THAT ALL OF THE TEST EQUIPMENT IS IN GOOD WORKING CONDITION, AND IS PROPERLY CONFIGURED AND CALIBRATED.
5.4. CONSTRUCT A TEST MANIFOLD WITH TWO AIR-SUPPLY GAUGES. EACH AIR SUPPLY GAUGE MUST HAVE A MAXIMUM FULL-SCALE READING OF 15 PSIG WITH 1/4"-LB. OR 1/10"-LB. INCREMENTS, AND A PRESSURE-RELIEF DEVICE SET AT 6 PSIG.
5.5. IT IS THE INSTALLER'S RESPONSIBILITY TO SELECT A THREAD SEALANT THAT IS COMPATIBLE WITH THE PRODUCT BEING STORED.
5.6. WHEN CHECKING THE TANK FOR LEAKS DURING AN AIR/SOAP TEST, ROTATE THE TANK TO CHECK THE BOTTOM.
5.7. BEFORE ROTATING THE TANK DURING AN AIR/SOAP TEST, PLACE PROTECTIVE MATERIAL ON THE AREA ON WHICH THE TANK WILL BE ROTATED.
5.8. ROTATE THE TANK SLOWLY AND CAREFULLY TO AVOID DEVELOPING TOO MUCH MOMENTUM.
6. TANK TESTING
6.1. REMOVE ALL TEMPORARY SERVICE-FITTING PLUGS.
6.2. RE-DOPE FITTINGS AND INSTALL PLUGS IN ALL OPENINGS, EXCEPT ONE SERVICE FITTING.
6.3. INSTALL THE TEST MANIFOLD IN THE OPEN SERVICE FITTING.
6.4. PRESSURIZE THE TANK TO 5 PSIG.
6.5. SOAP THE ENTIRE EXTERIOR OF THE TANK, CHECKING FOR LEAKS.
6.6. MONITOR THE PRESSURE FOR ONE HOUR.
6.7. WHEN THE TEST IS COMPLETE, CAREFULLY RELEASE THE AIR PRESSURE FROM THE TANK.
6.8. WHEN AIRFLOW STOPS, REMOVE THE TEST MANIFOLD.

6. TANK TESTING

- 6.1. REMOVE ALL TEMPORARY SERVICE-FITTING PLUGS.
6.2. RE-DOPE FITTINGS AND INSTALL PLUGS IN ALL OPENINGS, EXCEPT ONE SERVICE FITTING (NEEDED FOR THE TEST MANIFOLD).
6.3. INSTALL THE TEST MANIFOLD IN THE OPEN SERVICE FITTING.
6.4. PRESSURIZE THE TANK TO 5 PSIG.
6.5. SOAP THE ENTIRE EXTERIOR OF THE TANK, CHECKING FOR LEAKS.
6.6. MONITOR THE PRESSURE FOR ONE HOUR.
6.7. WHEN THE TEST IS COMPLETE, CAREFULLY RELEASE THE AIR PRESSURE FROM THE TANK.
6.8. WHEN AIRFLOW STOPS, REMOVE THE TEST MANIFOLD.

6.10. REPLACE THE PROTECTIVE COVERS IN THE SERVICE FITTINGS.

7. BACKFILL MATERIAL

- 7.1. TANKS MUST BE INSTALLED USING EITHER PEA GRAVEL OR CRUSHED STONE AS BACKFILL MATERIAL.
7.2. USING OTHER THAN APPROVED BEDDING AND BACKFILL MATERIALS WITHOUT PRIOR WRITTEN AUTHORIZATION FROM HOWARD COUNTY DPW IS PROHIBITED.
7.3. USE OF UNAPPROVED BACKFILL MATERIAL MAY CAUSE TANK FAILURE, OR DAMAGE THE TANK OR SURROUNDING PROPERTY.
7.4. APPROVED BACKFILL MATERIAL MUST MEET THE FOLLOWING SPECIFICATIONS:
7.4.1. THE MATERIAL IS WASHED, FREE-FLOWING, AND FREE OF ICE, SNOW AND DEBRIS.
7.4.2. WHEN USING PEA GRAVEL, THE MATERIAL IS TO BE A MIX OF ROUNDED PARTICLES, SIZES BETWEEN 1/8 INCH AND 3/4 INCH.
7.4.3. WHEN USING CRUSHED STONE, THE MATERIAL IS TO BE A MIX OF ANGULAR PARTICLES, SIZES BETWEEN 1/8 INCH AND 1/2 INCH.
7.4.4. NO MORE THAN 5% (BY WEIGHT) OF THE MATERIAL MAY PASS THROUGH A #8 SIEVE.
7.4.5. THE MATERIALS SUPPLIER SHALL CERTIFY THAT THE MATERIAL CONFORMS TO ASTM C-33 AND ANY OTHER APPLICABLE SPECIFICATIONS.

8. EXCAVATION

- 8.1. CONTRACTOR MUST TAKE ALL PRECAUTIONS NECESSARY TO PROTECT EMPLOYEES WORKING IN OR NEAR A TANK EXCAVATION.
8.2. LOCATE AND PROTECT ANY UTILITY INSTALLATIONS NEAR THE EXCAVATION BEFORE OPENING THE EXCAVATION.
8.3. SECURE THE WALLS OF THE EXCAVATION.
8.4. PREVENT EXPOSURE OF EMPLOYEES TO HAZARDOUS FUMES FROM THE EXCAVATION.
8.5. PROTECT EMPLOYEES FROM HAZARDS ASSOCIATED WITH WATER ACCUMULATION IN THE EXCAVATION.
8.6. ERECT BARRICADES, ETC., TO PREVENT UNAUTHORIZED VEHICLE OR PEDESTRIAN TRAFFIC.
8.7. INSPECT, A MINIMUM OF ONCE A DAY, THE EXCAVATION AND SURROUNDING AREA.

9. BURIAL DEPTH

- 9.1. TANKS SUBJECTED TO TRAFFIC LOADS (H=20 LOADS) MUST HAVE A COVER DEPTH OF AT LEAST 36 INCHES OF BACKFILL, OR 18 INCHES OF BACKFILL PLUS 6 INCHES OF REINFORCED CONCRETE OR 9 INCHES OF ASPHALT.
9.2. TANKS NOT SUBJECTED TO TRAFFIC LOADS MUST HAVE A COVER DEPTH OF AT LEAST 24 INCHES OF BACKFILL, OR 12 INCHES OF BACKFILL PLUS 4 INCHES OF REINFORCED CONCRETE OR 6 INCHES OF ASPHALT.
9.3. IN A NONTRAFFIC INSTALLATION, ENSURE THAT THE AREAS ABOVE THE TANKS ARE NOT SUBJECTED TO TRAFFIC OR OTHER TYPES OF LOADS, WHICH COULD CAUSE TANK DAMAGE AND RESULT IN DEATH OR SERIOUS INJURY.
9.4. THE MAXIMUM BURIAL DEPTH IS 7 FEET OF COVER OVER THE TOP OF THE TANK.
9.5. IF THERE IS AN UNATTACHED MANWAY RISER, IT MUST NOT TRANSMIT LOAD FROM THE CONCRETE SLAB TO THE TANK.
9.6. TRAFFIC LOADS FROM THE TOP SLAB MUST NOT BE TRANSMITTED TO AN ATTACHED SUMP OR RISER.

10. UNSTABLE IN SITU SOIL CONDITIONS

- 10.1. IF THE SOIL HAS LESS THAN 750 LBS./SQ. FT. COHESION AS CALCULATED FROM AN UNCONFINED COMPRESSION TEST, OR IN SOILS HAVING AN ULTIMATE BEARING CAPACITY OF LESS THAN 3,500 LBS./SQ. FT., OR WHERE SOIL WILL NOT MAINTAIN A VERTICAL WALL, THE EXCAVATION MUST ALLOW A MINIMUM SPACE EQUAL TO HALF THE DIAMETER OF THE TANK BETWEEN THE EXCAVATION WALL AND BOTH THE SIDE AND THE ENDCAP OF THE TANK.
10.2. A REINFORCED CONCRETE SLAB MAY BE REQUIRED UNDER THE TANK AS A FOUNDATION IN THE EXCAVATION WHERE THE BOTTOM IS UNSTABLE.

11. TANK LOCATION

- 11.1. THE CONTRACTOR SHALL SEEK THE ADVICE OF A MARYLAND-LICENSED PROFESSIONAL ENGINEER TO DETERMINE THE PROPER PLACEMENT OF A TANK EXCAVATION NEAR ANY EXISTING STRUCTURE(S).
11.2. ENSURE THAT DOWNWARD FORCES FROM LOADS CARRIED BY THE FOUNDATIONS AND SUPPORTS OF NEARBY STRUCTURES (CONSTRUCTED BEFORE OR AFTER TANK INSTALLATION) ARE NOT TRANSMITTED TO THE TANKS.

12. GEOTEXTILE

- 12.1. GEOTEXTILE ALLOWS THE PASSAGE OF WATER BUT PREVENTS THE MIGRATION AND MIXING OF IN SITU SOIL AND THE SELECT BACKFILL MATERIAL.
12.2. GEOTEXTILE ENVELOPE IS REQUIRED ON ALL UNDERGROUND TANK INSTALLATIONS
12.3. POLYETHYLENE FILM IS NOT AN ACCEPTABLE SUBSTITUTE FOR GEOTEXTILE

SPECIFICATIONS ARE CONTINUED ON SHEET 3 OF 7

PROFESSIONAL CERTIFICATION: I hereby certify that these documents were prepared or approved by me, and that I am a duly licensed professional engineer under the laws of the State of Maryland, License No. 31363, Expiration Date 01/16/2018.

KCI TECHNOLOGIES PROJECT NO.: 13122677-38

Jul 10, 2017 - 11:35am User: khm\jackson Mailto:kfj@kci77.com Drawing Sheets 7-102\_SPECIFICATIONS\_1.rvt

DEPARTMENT OF PUBLIC WORKS HOWARD COUNTY, MARYLAND. Includes signatures and dates for Director of Public Works, Chief of Bureau of Engineering, and Chief of Utility Design Division.

KCI TECHNOLOGIES logo and contact information: 936 Ridgebrook Road, Sparks, MD 21152, Phone: (410) 316-7800.

Professional Engineer Seal for J. M. Quinn, License No. 31363, State of Maryland, Expiration Date 01/16/2018.

Table with columns: DES: KFJ, DRN: KFJ, CHK: GW, DATE: JULY, 2017, BY, NO., REVISION, DATE.

UNDERGROUND WATER STORAGE TANKS FOR FIRE SUPPRESSION. CAPITAL PROJECT No. F-5972, CONTRACT No. 65-4959. HOWARD COUNTY, MARYLAND.

13. ANCHORING TANKS
- 13.1 EVERY SITE SHALL BE THOROUGHLY EVALUATED FOR THE POTENTIAL OF A RISE IN THE LOCAL WATER TABLE OR OF TRAPPED WATER. FAILURE TO ANCHOR A TANK WHEN REQUIRED MAY CAUSE TANK FAILURE, OR DAMAGE THE TANK OR SURROUNDING PROPERTY.
- 13.2 UNLESS NOTED OTHERWISE ON THE DRAWINGS, DEADMEN USED TO PREVENT FLOATATION SHALL HAVE THE FOLLOWING CHARACTERISTICS:
- 13.1.1. DEADMEN SHALL BE REINFORCED CONCRETE BEAMS.
  - 13.1.2. THE LENGTH OF DEADMEN SHALL BE EQUAL TO THE LENGTH OF THE TANK, AT A MINIMUM.
  - 13.1.3. PREFABRICATED DEADMEN ARE SUPPLIED WITH 3/4 -INCH-DIAMETER, GALVANIZED, ADJUSTABLE ANCHOR POINTS (SUBSEQUENTLY REFERRED TO AS ANCHOR POINTS). THESE ANCHOR POINTS PROTRUDE UP THROUGH THE SLOTS IN THE DEADMEN AND ARE HELD UP WITH COTTER PINS.
- 13.3 ONLY USE THE ANCHOR POINTS WHEN LIFTING AND POSITIONING THE DEADMEN. A SPREADER BAR MAY BE REQUIRED TO LIFT LONGER SECTIONS OF DEADMEN. USE GUY ROPES TO GUIDE THE DEADMEN WHEN LIFTING.
- 13.4 THE ANCHOR POINTS CAN BE MOVED AND POSITIONED TO MATCH THE HOLD-DOWN STRAP LOCATIONS ON THE TANK
- 13.5 CARE SHOULD BE TAKEN TO KEEP BACKFILL FROM ENTERING THE ANCHOR-POINT SLOT UNTIL FINAL ADJUSTMENT IS MADE.
- 13.6 THE DEADMEN ARE TO BE BUTTED TOGETHER WHEN MULTIPLE SECTIONS ARE USED.
- 13.7 USE ONE ANCHOR POINT PER STRAP END AND ONLY ONE STRAP PER ANCHOR POINT.
14. ANCHOR SLAB (GROUNDWATER INSTALLATION ONLY)
- 14.1 THE ANCHOR SLAB SHALL BE REINFORCED CONCRETE.
  - 14.2 THE TOTAL LENGTH OF THE SLAB SHALL BE AT LEAST THE SAME AS THE LENGTH OF THE TANK.
  - 14.3 THE MINIMUM SLAB THICKNESS IS 8 INCHES.
  - 14.4 THE WIDTH OF THE SLAB DEPENDS ON THE TANK DIAMETER. THE SLAB SHALL EXTEND A MINIMUM OF 18 INCHES BEYOND EACH SIDE OF THE TANK.
  - 14.5 PROVIDE A SEPARATE ANCHOR POINT FOR EACH HOLD-DOWN STRAP.
  - 14.6 ALL ANCHOR POINTS MUST BE ENGINEERED TO WITHSTAND THE TANK'S BUOYANCY FORCES.
  - 14.7 WHEN USING A CONCRETE BASE SLAB, ALLOW SUFFICIENT DEPTH IN THE EXCAVATION FOR 12 INCHES OF BEDDING MATERIAL BELOW THE TANK.
15. HOLD-DOWN STRAPS
- 15.1 EVENLY DISTRIBUTE LOADS BY TIGHTENING ALL HOLD-DOWN STRAPS UNIFORMLY UNTIL THEY ARE SNUG OVER THE RIBS BUT CAUSE NO DEFLECTION OF THE TANK.
  - 15.2 TAKE A MEASUREMENT OF THE INTERNAL DIAMETER OF THE TANK TO DETERMINE WHETHER VERTICAL DEFLECTION IS WITHIN THE LIMITS SPECIFIED AFTER THE STRAPS HAVE BEEN INSTALLED AND TIGHTENED.
  - 15.3 ALL ANCHORING HARDWARE SHALL BE GALVANIZED AND SIZED ACCORDING TO THE FOLLOWING MINIMUM REQUIREMENTS (FOR A 10' DIAMETER TANK):
    - 15.3.1. HOOK - 1 1/4"
    - 15.3.2. JAW - 3/4"
    - 15.3.3. EYE - 3/4"
    - 15.3.4. WIRE ROPE - 1/2"
  - 15.4 THE INSTALLING CONTRACTOR IS RESPONSIBLE FOR PROVIDING HARDWARE AND ANCHOR POINTS OF SUFFICIENT SIZE AND STRENGTH.
  - 15.5 THE PARTICULAR CONFIGURATION OF HARDWARE WILL BE DETERMINED BY THE CONTRACTOR, THE OWNER OR THE OWNER'S REPRESENTATIVE.
16. INSTALLATION
- 16.1 USE ONLY APPROVED BACKFILL MATERIAL.
  - 16.2 DO NOT MIX APPROVED BACKFILL MATERIAL WITH SAND OR IN SITU SOIL.
  - 16.3 DO NOT USE IN SITU SOIL AS BACKFILL MATERIAL.
  - 16.4 PREPARE A SMOOTH, LEVEL BED, 12 INCHES THICK, OF APPROVED BACKFILL MATERIAL.
  - 16.5 PLACE THE TANK OR TANKS ONTO THE BED.
  - 16.6 USE THE TOPS OF THE RIBS TO ESTABLISH LONGITUDINAL LEVEL. ESTABLISH LATERAL LEVEL BY PLACING THE LEVEL ACROSS THE TOP OF A FITTING OR A MANWAY.
  - 16.7 WHEN THE TANK IS PLACED, TAKE A MEASUREMENT OF THE INTERNAL DIAMETER OF THE TANK. RECORD THIS MEASUREMENT AS INITIAL INTERNAL DIAMETER ON THE TANK INSTALLATION CHECKLIST.
  - 16.8 IF THE TANK IS TO BE ANCHORED, INSTALL THE ANCHORING HARDWARE AT THIS TIME.
  - 16.9 PLACE ONE 12-INCH LIFT OF APPROVED BACKFILL MATERIAL EVENLY AROUND THE TANK. FROM THE EDGE OF THE HOLE OR THE TOP OF AN ADJACENT TANK, PUSH THE BACKFILL IN PLACE BY USING A NON-METAL PROBE LONG ENOUGH TO REACH BENEATH THE TANK. WORK THE BACKFILL MATERIAL UNDER THE TANK BODY AND DOMES SO THE TANK IS FULLY SUPPORTED - THAT IS, SO THERE ARE NO VOIDS UNDER THE TANK.
  - 16.10 REPEAT POINT 16.9 WITH A SECOND 12-INCH LIFT.
  - 16.11 AFTER THE SECOND LIFT OF MATERIAL HAS BEEN PLACED AND WORKED UNDER THE TANK, BRING THE BACKFILL TO THE TOP OF THE TANK.

- 16.12 FOR GROUNDWATER INSTALLATION, FOLLOW THE INSTALLATION PROCEDURE ABOVE WITH THE FOLLOWING MODIFICATIONS:
- 16.12.1. BEFORE PERFORMING POINT 16.4 OF THE DRY-HOLE INSTALLATION, TAKE A MEASUREMENT OF THE INTERNAL DIAMETER OF THE TANK BEFORE THE TANK IS PLACED IN THE EXCAVATION HOLE. RECORD THIS MEASUREMENT AS INITIAL INTERNAL DIAMETER ON THE TANK INSTALLATION CHECKLIST.
  - 16.12.2. BEFORE PERFORMING POINT 16.4 OF THE DRY-HOLE INSTALLATION, PUMP THE WATER FROM THE HOLE AND CONTINUE PUMPING TO MAINTAIN MINIMUM WATER LEVEL DURING TANK INSTALLATION.
  - 16.12.3. DURING POINT 16.5 OF THE DRY-HOLE INSTALLATION, WHEN SETTING AND LEVELING THE TANK, PARTIALLY BALLAST THE TANK UNTIL IT SETTLES FIRMLY ON THE PREPARED BED. THE BALLAST LEVEL IN THE TANK MUST NEVER EXCEED THE WATER LEVEL IN THE HOLE BY MORE THAN 1 FOOT UNTIL THE BACKFILL REACHES THE TOP OF THE TANK.
  - 16.12.4. COVER DEPTH MUST MEET MINIMUM DEPTH SPECIFIED IN SECTION 9.
  - 16.12.5. COMPLETELY BALLAST THE TANK ONCE BACKFILL IS EVEN WITH THE TOP OF THE TANK.
  - 16.12.6. AFTER BACKFILL IS BROUGHT TO THE TOP OF THE TANK, TAKE A MEASUREMENT OF THE INTERNAL DIAMETER OF THE TANK AS A DEFLECTION CHECK.
17. POST-INSTALLATION TESTING
- 17.1 AFTER THE INTERNAL DIAMETER OF THE TANK HAS BEEN MEASURED AND VERTICAL DEFLECTION IS DETERMINED TO BE WITHIN THE LIMITS THE TANK MUST BE PRESSURE-TESTED TO ENSURE THAT NO DAMAGE OCCURRED DURING INSTALLATION.
  - 17.2 FOLLOW THE PROCEDURE IN SECTION 6, SOAPING ALL EXPOSED AREAS OF THE TANK AND ALL FITTINGS, AND MONITORING THE PRESSURE FOR ONE HOUR.
  - 17.3 CAREFULLY RELIEVE THE PRESSURE IN THE TANK.
18. BACKFILLING TO GRADE
- 18.1 CONTINUE TO TAKE SAFETY MEASURES (SUCH AS PLACING BARRICADES) AROUND THE EXCAVATION SITE UNTIL INSTALLATION IS COMPLETED.
  - 18.2 WHEN THE TANK HAS BEEN SET, TESTED AND BACKFILLED, AND ALL PIPING AND VENTING HAS BEEN COMPLETED, ADD THE BALANCE OF THE BACKFILL MATERIAL.
  - 18.3 THE BACKFILL MUST BE FREE OF DEBRIS, ICE OR SNOW. ANY BLOCKS OR BRICKS USED AS SUPPORT MATERIAL DURING PIPING MUST BE REMOVED PRIOR TO COMPLETION OF BACKFILLING.
  - 18.4 THE BACKFILL MATERIAL SPECIFIED IN SECTION 7 MUST BE USED TO COMPLETELY FILL EXCAVATION.
  - 18.5 THE INSTALLATION SHALL MEET ALL THE REQUIREMENTS OF MINIMUM COVER AS SPECIFIED IN SECTION 9.
  - 18.6 WHEN THE TANK HAS BEEN BACKFILLED TO SUBGRADE (BEFORE PLACEMENT OF ASPHALT OR CONCRETE), TAKE A MEASUREMENT OF THE INTERNAL DIAMETER OF THE TANK. RECORD THIS MEASUREMENT AS FINAL INTERNAL DIAMETER ON THE TANK INSTALLATION CHECKLIST.
  - 18.7 COMPLETE THE TANK INSTALLATION CHECKLIST.
19. DEFLECTION MEASUREMENT
- 19.1 OBTAIN THE DEFLECTION MEASUREMENT BY TAKING A MINIMUM OF TWO MEASUREMENTS OF THE INTERNAL DIAMETER OF THE TANK.
  - 19.2 TWO METHODS OF MEASURING THE INTERNAL DIAMETER OF THE TANK ARE DESCRIBED HERE. BOTH METHODS USE A DIPSTICK. (SIMILAR METHODS CAN BE USED, SUCH AS USING A TAPE MEASURE, ETC.)
  - 19.3 THE DEFLECTION MEASUREMENT CAN BE OBTAINED BY USING EITHER METHOD TWICE OR BY USING EACH METHOD ONCE. EACH WILL BE DESCRIBED HERE AS IF THAT METHOD WERE BEING USED TWICE.
  - 19.4 TAKE THE INITIAL INTERNAL-DIAMETER MEASUREMENT BEFORE BACKFILLING THE TANK, AND RECORD THE MEASUREMENT ON THE TANK INSTALLATION CHECKLIST. IN A GROUNDWATER INSTALLATION, TAKE THIS MEASUREMENT BEFORE THE TANK IS PLACED IN THE EXCAVATION HOLE.
  - 19.5 TAKE OTHER DIAMETER MEASUREMENTS DURING THE BACKFILLING PROCESS TO DETERMINE WHETHER VERTICAL DEFLECTION CONTINUES TO BE WITHIN THE LIMITS SPECIFIED BY THE TANK MANUFACTURER.
  - 19.6 TAKE THE FINAL INTERNAL-DIAMETER MEASUREMENT WHEN THE TANK HAS BEEN BACKFILLED TO SUBGRADE.
  - 19.7 TO GET THE DEFLECTION MEASUREMENT AT ANY TIME, SUBTRACT THE CURRENT INTERNAL-DIAMETER MEASUREMENT FROM THE INITIAL INTERNAL-DIAMETER MEASUREMENT.
  - 19.8 COMPARE THIS MEASUREMENT TO THE ALLOWABLE DEFLECTIONS PROVIDED BY THE TANK MANUFACTURER AND RECORD THE INFORMATION ON THE TANK INSTALLATION CHECKLIST.
  - 19.9 VERTICAL DEFLECTION IN EXCESS OF THIS MEASUREMENT INDICATES IMPROPER INSTALLATION AND VOIDS THE TANK WARRANTY.
20. OPERATING GUIDELINES
- 20.1 NO PERSON SHALL BE PERMITTED TO ENTER THE TANK UNLESS IT HAS BEEN PROPERLY EMPTIED AND VENTED, AND UNLESS THE PERSON ENTERING THE TANK HAS BEEN TRAINED IN CONFINED-SPACE ENTRY PROCEDURES, APPLICABLE OSHA REGULATIONS, AND IS IN POSSESSION OF A VALID HOWARD COUNTY CONFINED SPACE ENTRY PERMIT.
  - 20.2 NEVER OVERFILL THE TANK.
  - 20.3 EACH TIME THE TANK IS FILLED, THE OWNER/OPERATOR SHALL MAKE SURE THE TANK IS PROPERLY VENTED.
  - 20.4 OWNER/OPERATOR SHALL DETERMINE WHETHER THE TANK HAS OVERFILL PROTECTION, SUCH AS AUTOMATIC SHUT-OFF DEVICES OR VENT-RESTRICTION DEVICES ('BALL-FLOAT VALVES'), WHICH WILL CLOSE OFF THE INTERNAL PIPING AND REDUCE THE TANK'S CAPACITY.
  - 20.5 OWNER/OPERATOR SHALL NOTIFY WHOEVER FILLS THE TANK THAT IT HAS OVERFILL PROTECTION, WHICH REDUCES THE TANK'S CAPACITY.
  - 20.6 BEFORE EACH TANK FILLING, OWNER/OPERATOR OR THE DELIVERY SERVICE MUST DETERMINE THE TANK'S REDUCED CAPACITY DUE TO THE OVERFILL PROTECTION, AND CONSULT THE INSTRUCTIONS OR GUIDELINES PROVIDED BY THE INSTALLER AND MANUFACTURER OF THE OVERFILL-PROTECTION DEVICE TO DETERMINE HOW MUCH ADDITIONAL PRODUCT THE TANK CAN HOLD.
  - 20.7 THE MAXIMUM TEMPERATURE FOR STORING NONPOTABLE WATER IS 150° F. NOTE: POTABLE WATER IS TO BE STORED AT AMBIENT TEMPERATURE.

PROFESSIONAL CERTIFICATION: I hereby certify that these documents were prepared or approved by me, and that I am a duly licensed professional engineer under the laws of the State of Maryland, License No. 31363. Expiration Date 01/16/2018.

DEPARTMENT OF PUBLIC WORKS HOWARD COUNTY, MARYLAND	
Director of Public Works <i>[Signature]</i> 7/20/17 DATE	Chief, Bureau of Engineering <i>[Signature]</i> 7/18/17 DATE
Chief, Bureau of Utilities <i>[Signature]</i> 7/20/17 DATE	Chief, Utility Design Division <i>[Signature]</i> 7/18/17 DATE



936 Ridgeway Road  
 Sparks, MD 21152  
 Phone: (410) 316-7800  
 Fax: (410) 316-7817  
 www.kci.com

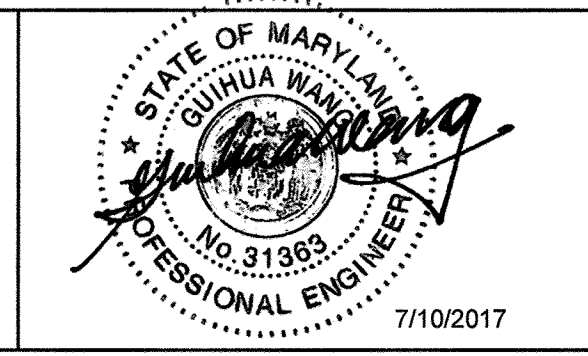

DES:	KFJ				
DRN:	KFJ				
CHK:	GW				
DATE:	JULY, 2017	BY	NO.	REVISION	DATE

SPECIFICATIONS - 2

UNDERGROUND WATER STORAGE TANKS FOR FIRE SUPPRESSION

CAPITAL PROJECT No. F-5972  
 CONTRACT No. 65-4959  
 HOWARD COUNTY, MARYLAND

KCI TECHNOLOGIES PROJECT No.: 13122677.38

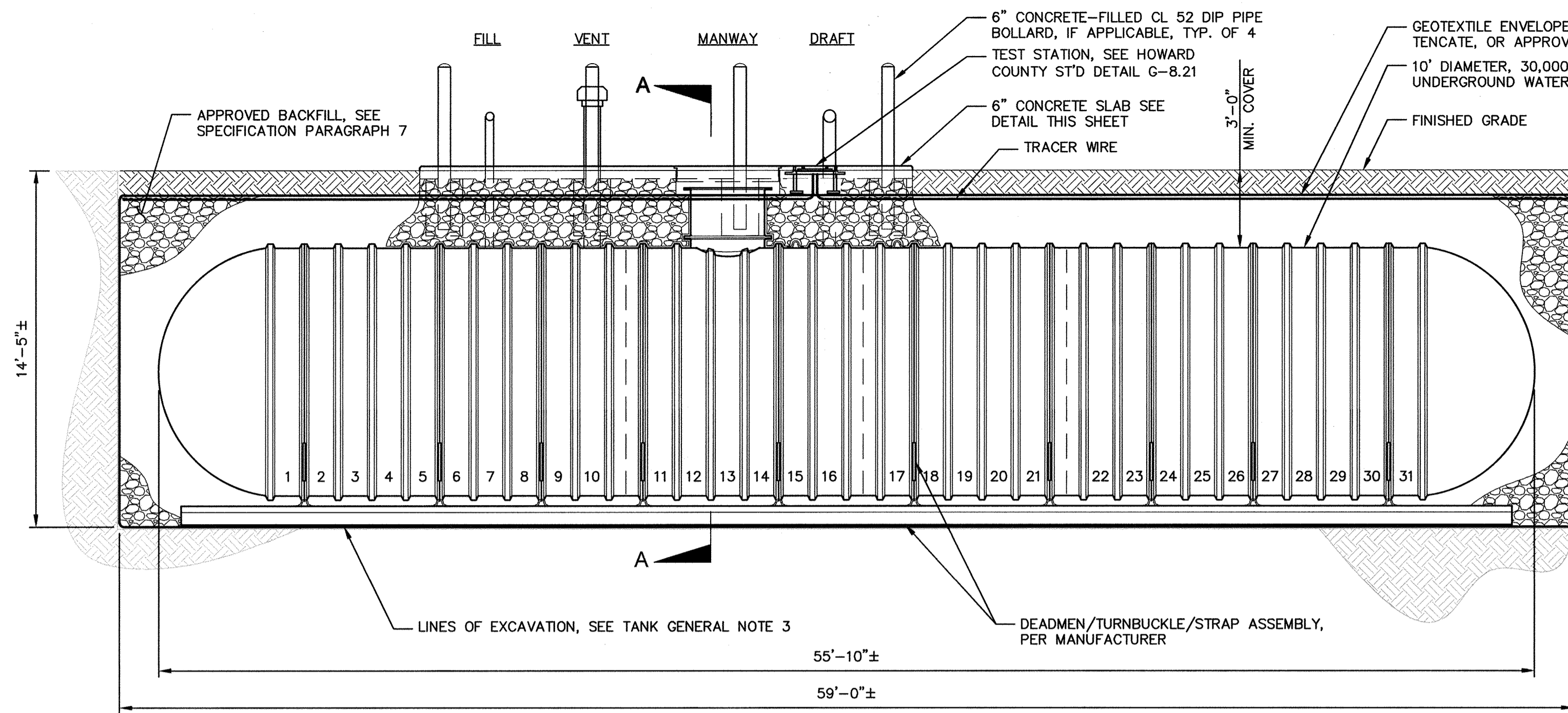

**ELEVATION: 30,000 GALLON FIRE SUPPRESSION WATER STORAGE TANK**  
SCALE: 1/4" = 1'-0"

**NOTE:**  
TANK DIMENSIONS AND LAYOUT ARE FOR REFERENCE ONLY. ACTUAL TANK DIMENSIONS WILL VARY WITH MANUFACTURER. FITTINGS SHALL BE PER DETAILS ON SHEET 5 OF 7.

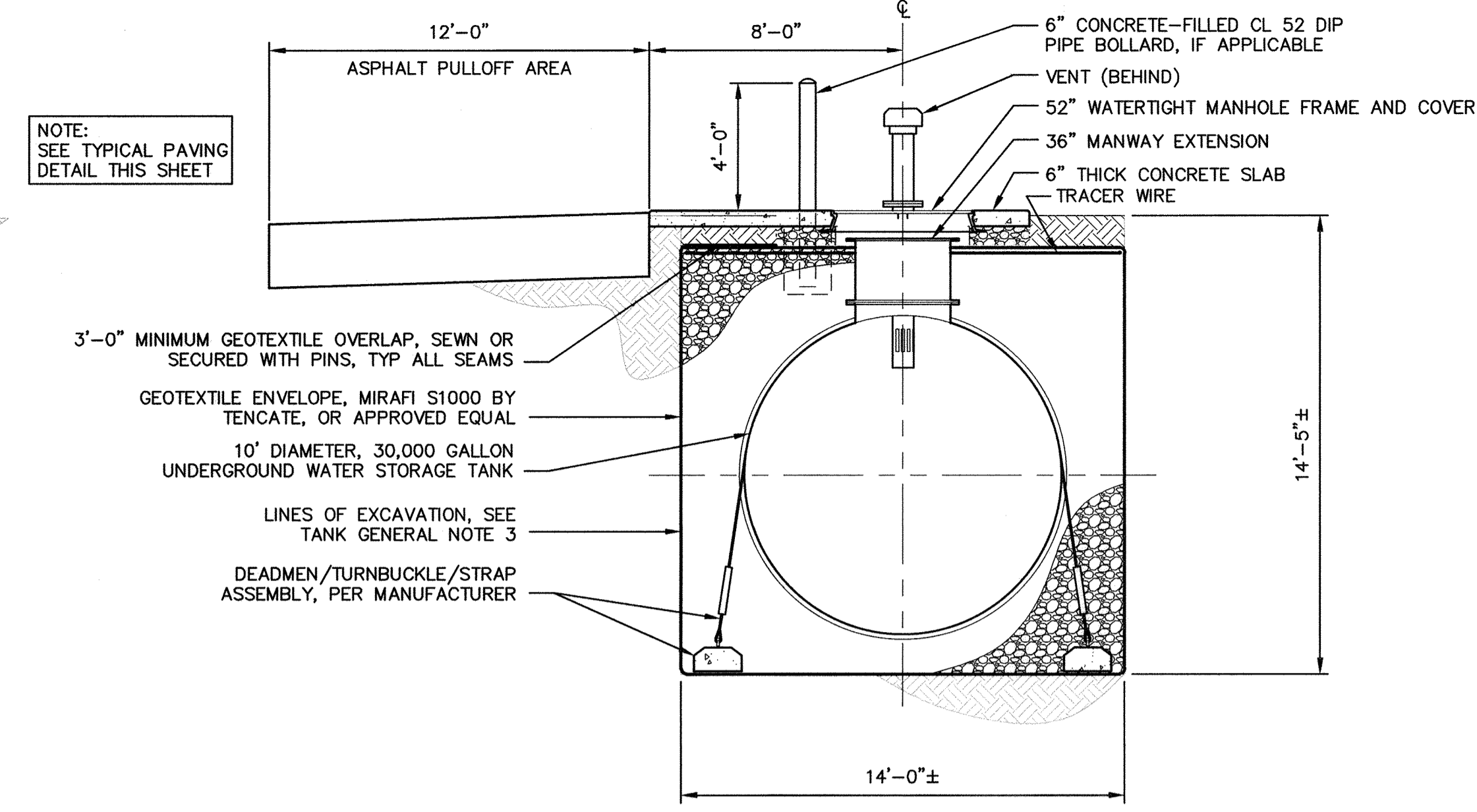

**SECTION A-A**  
SCALE: 1/4" = 1'-0"

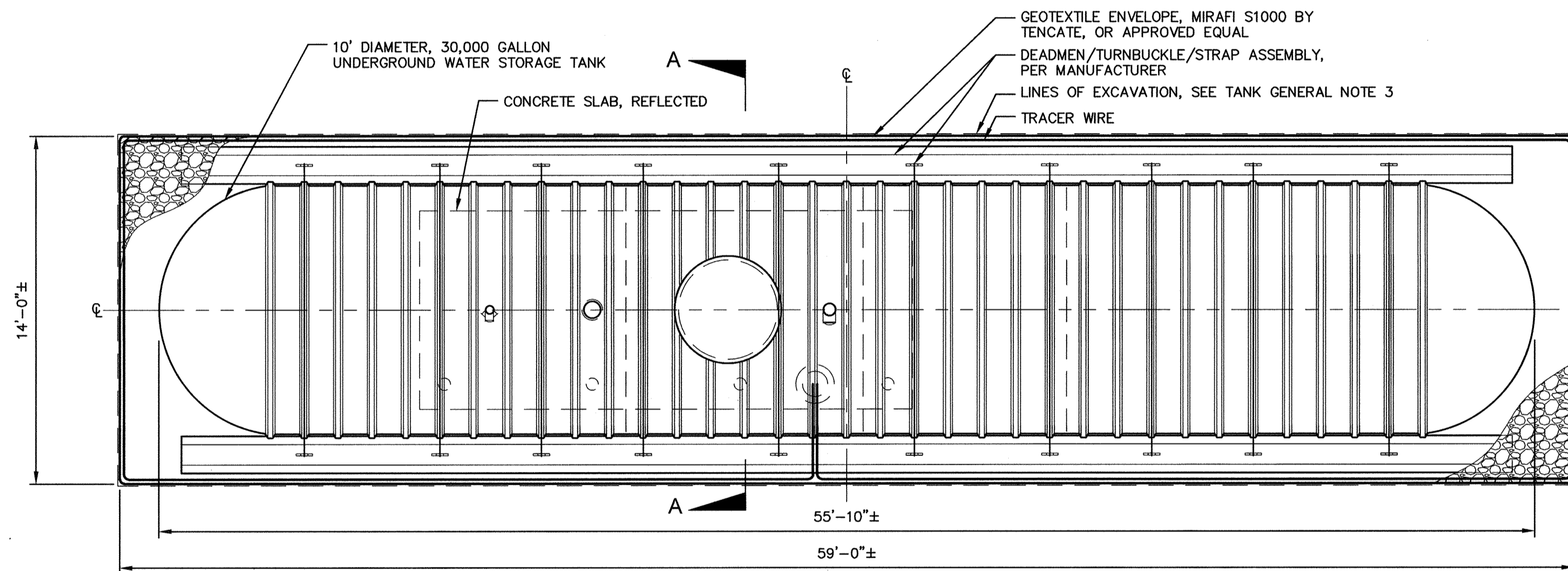

**PLAN: 30,000 GALLON FIRE SUPPRESSION WATER STORAGE TANK**  
SCALE: 1/4" = 1'-0"

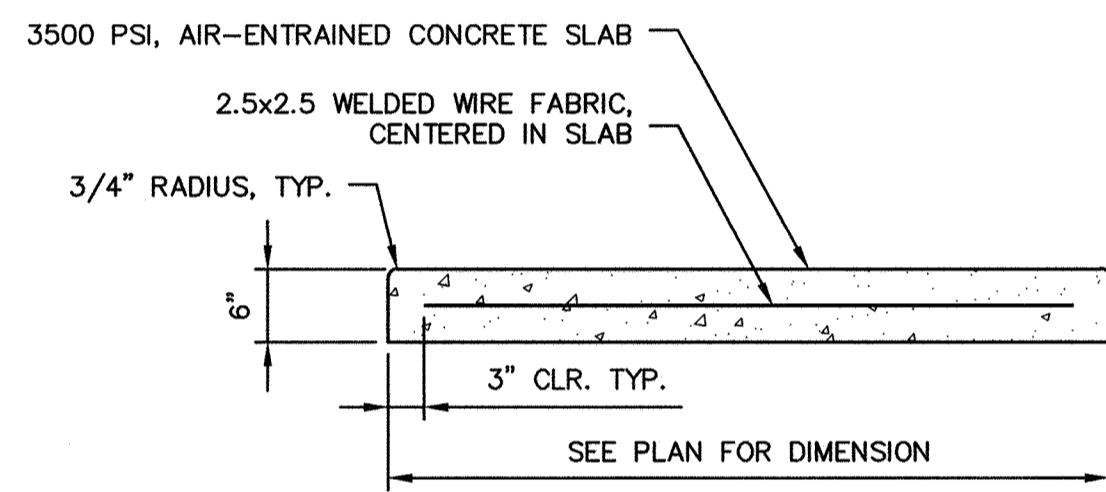

**DETAIL: CONCRETE SLAB TYPICAL SECTION**  
SCALE: 3/4" = 1'-0"

**PAVING NOTES:**

- PAVING SHALL COMPLY WITH THE LATEST EDITION OF THE HOWARD COUNTY VOLUME IV DESIGN MANUAL, STANDARD SPECIFICATIONS AND DETAILS FOR CONSTRUCTION.
- PAVING FOR THE ASPHALT PULLOFF SHALL CONFORM TO DETAIL R-2.02, SECTION NUMBER P-6 OF THE LATEST EDITION OF THE HOWARD COUNTY DESIGN MANUAL.
- HOWARD COUNTY DPW RESERVES THE RIGHT TO REQUIRE AN ALTERNATE PAVING SECTION, BASED ON SITE CONDITIONS OR VEHICULAR REQUIREMENTS.
- ALL PAVING THICKNESSES SHOWN, DIMENSIONED OR OTHERWISE NOTED ARE MINIMUM THICKNESSES.

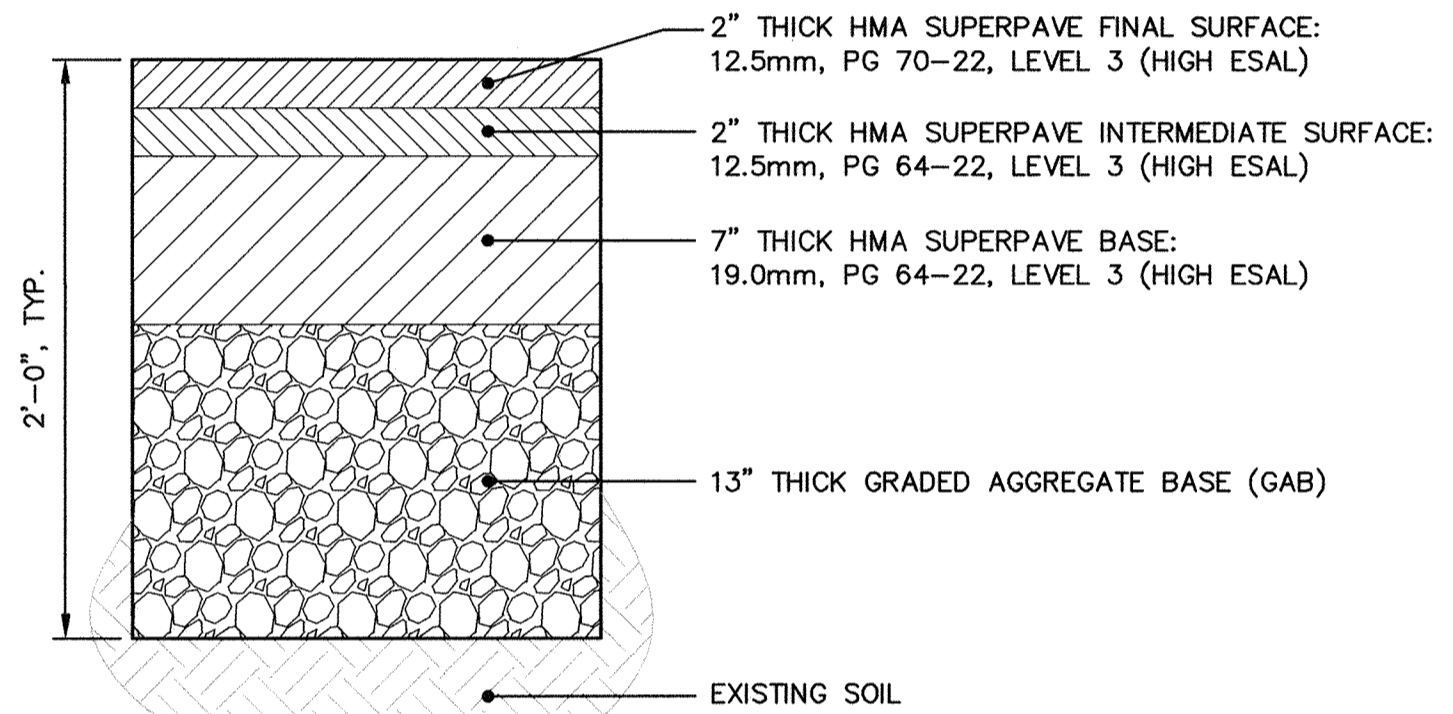

**DETAIL: PAVING TYPICAL SECTION**  
SCALE: 1 1/2" = 1'-0"

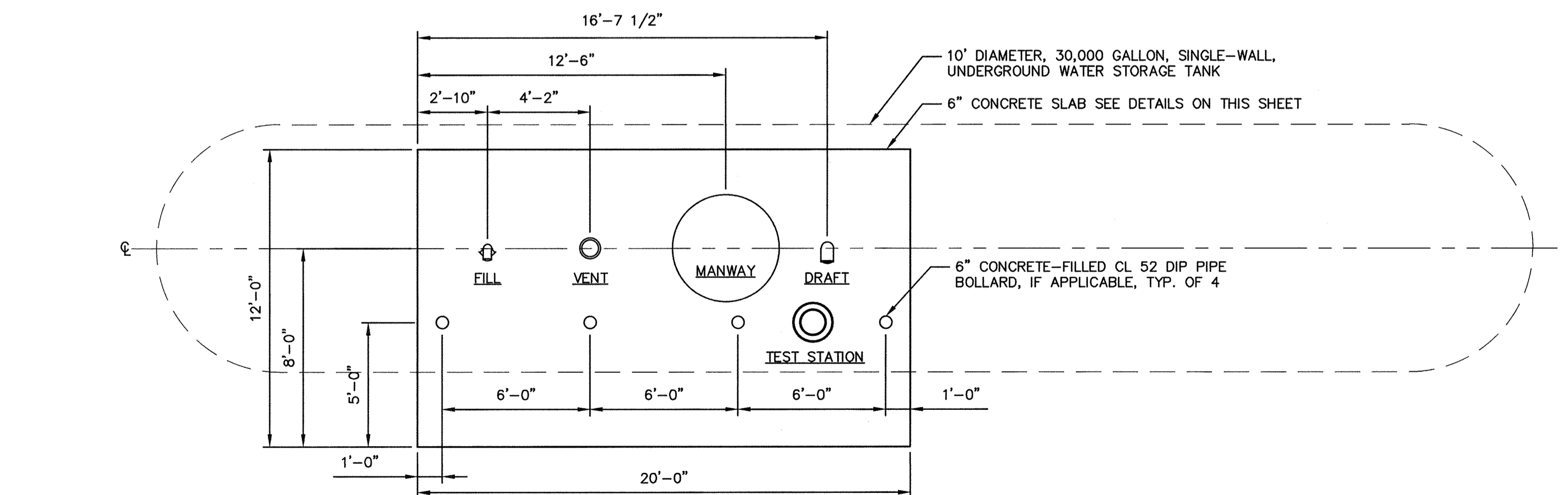

**DETAIL: CONCRETE SLAB**  
SCALE: 1/4" = 1'-0"

PROFESSIONAL CERTIFICATION: I hereby certify that these documents were prepared or approved by me, and that I am a duly licensed professional engineer under the laws of the State of Maryland, License No. 31363, Expiration Date 01/16/2018.

**NOTE:**  
BOLLARDS SHALL ONLY BE INSTALLED AT THE DIRECTION OF HOWARD COUNTY.

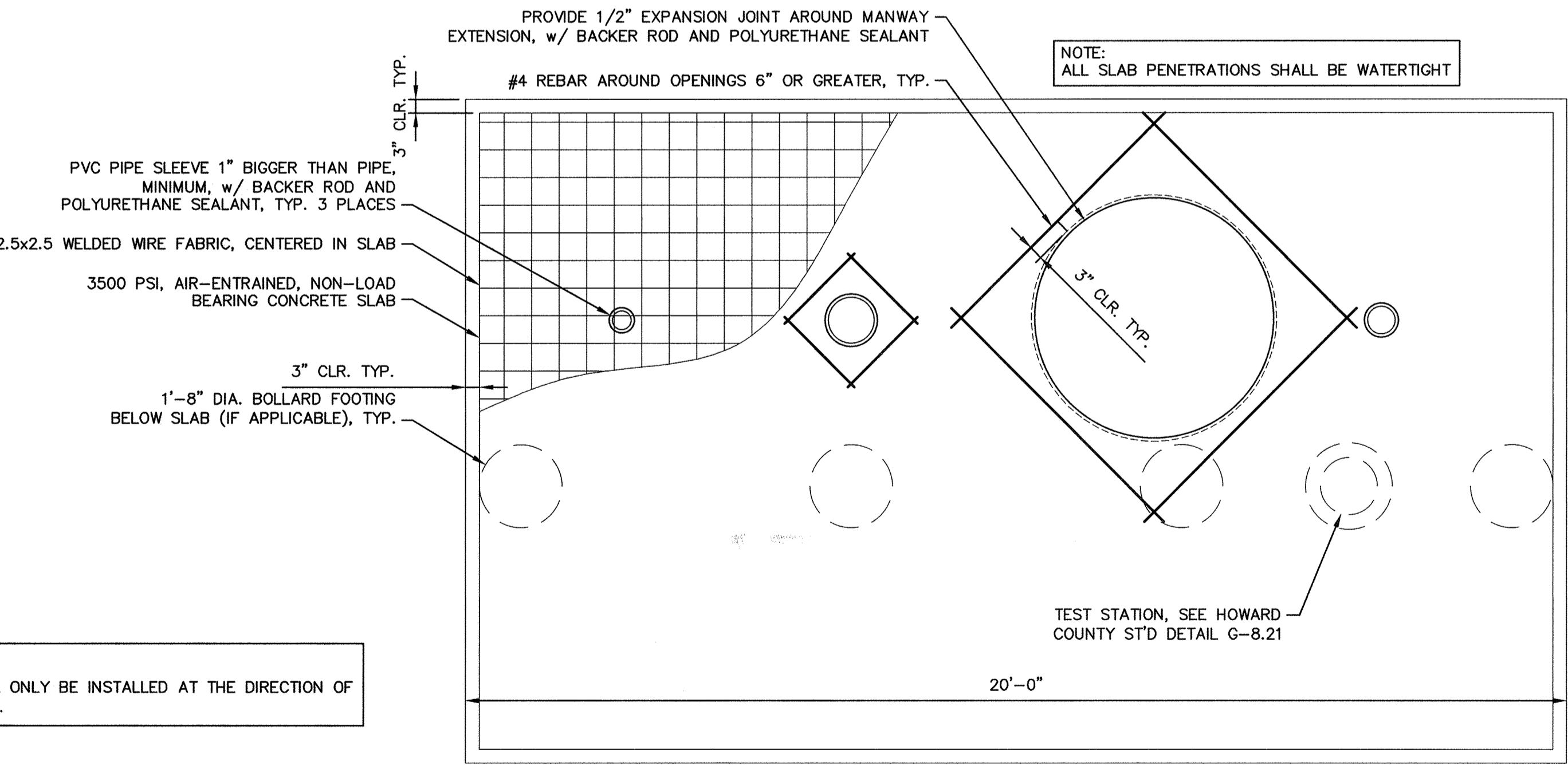

**DETAIL: CONCRETE SLAB REINFORCEMENT**  
SCALE: 1/2" = 1'-0"

Jul 10, 2017 - 11:28am User: kci\jacobson M:\2017\13122677-38\Drawings\Common Sheets\1704\_GENERAL DETAILS - 1.dwg

DEPARTMENT OF PUBLIC WORKS  
HOWARD COUNTY, MARYLAND

*James P. Butler* 7/18/17  
DIRECTOR OF PUBLIC WORKS DATE

*Thomas P. Butler* 7/18/17  
CHIEF, BUREAU OF ENGINEERING DATE

*David S. ...* 7/18/17  
CHIEF, BUREAU OF UTILITIES DATE

*...* 7/18/17  
CHIEF, UTILITY DESIGN DIVISION DATE PSD

ENGINEERS  
PLANNERS  
SCIENTISTS  
CONSTRUCTION MANAGERS

**KCI TECHNOLOGIES**

936 Ridgebrook Road  
Sparks, MD 21152  
Phone: (410) 316-7800  
Fax: (410) 316-7817  
www.kci.com

STATE OF MARYLAND  
GUTHRIE WALKER  
NO. 31363  
PROFESSIONAL ENGINEER  
7/10/2017

DES: KFJ				
DRN: KFJ				
CHK: GW				
DATE: JULY, 2017	BY	NO.	REVISION	DATE

**GENERAL DETAILS - 1**

**UNDERGROUND WATER STORAGE TANKS FOR FIRE SUPPRESSION**

CAPITAL PROJECT No. F-5972  
CONTRACT No. 65-4959  
HOWARD COUNTY, MARYLAND

SCALE  
AS SHOWN

SHEET  
4 OF 7

KCI TECHNOLOGIES PROJECT NO.: 13122677.38

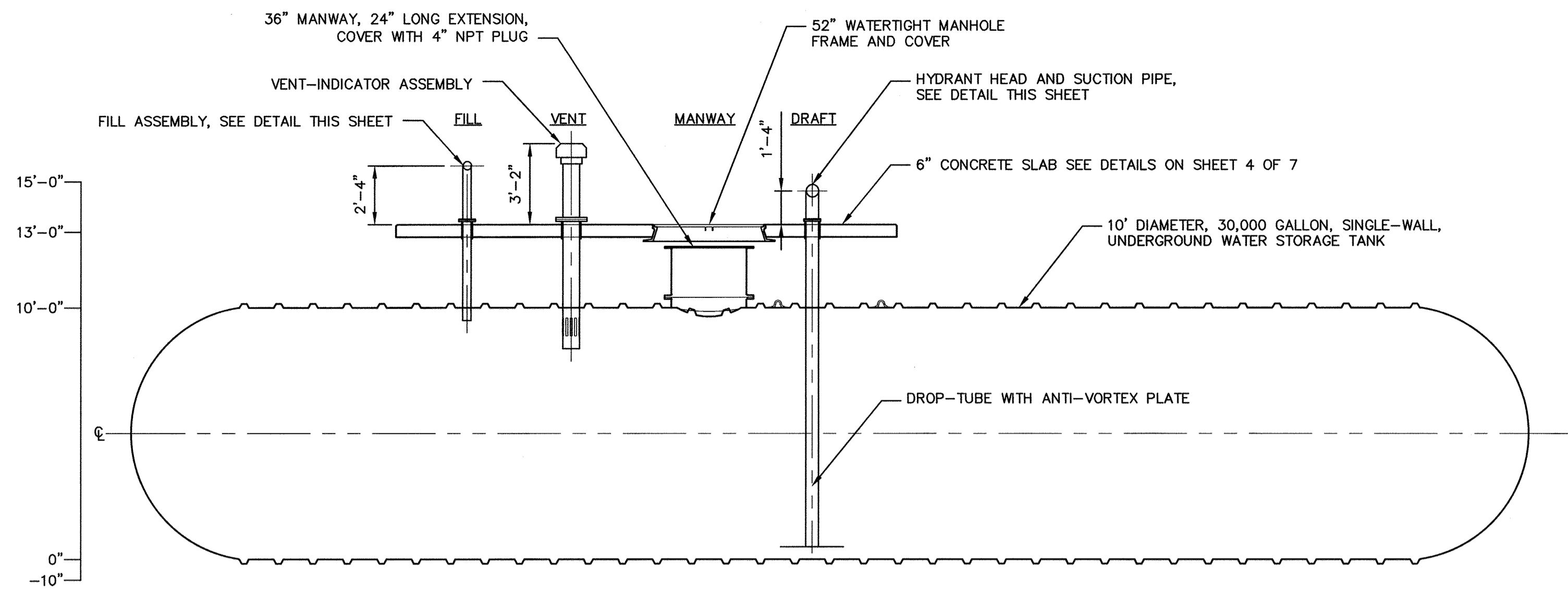

**SECTION THROUGH 30,000 GALLON FIRE SUPPRESSION WATER STORAGE TANK**  
SCALE: 1/4" = 1'-0"

**NOTE:**  
TANK DIMENSIONS AND LAYOUT ARE FOR REFERENCE ONLY. ACTUAL TANK DIMENSIONS WILL VARY WITH MANUFACTURER.

**NOTE:**  
BOLLARDS SHALL ONLY BE INSTALLED AT THE DIRECTION OF HOWARD COUNTY.

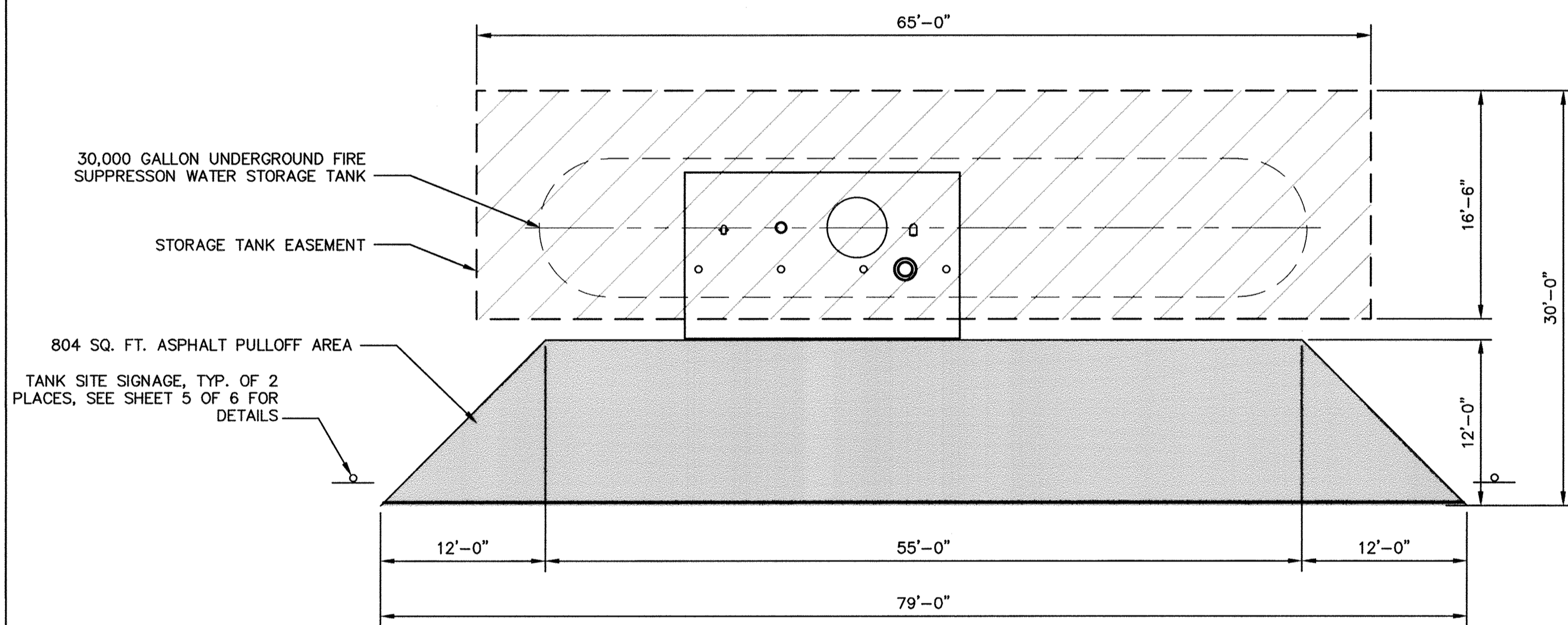

**DETAIL: TYPICAL TANK SITE LAYOUT**  
SCALE: 1/8" = 1'-0"

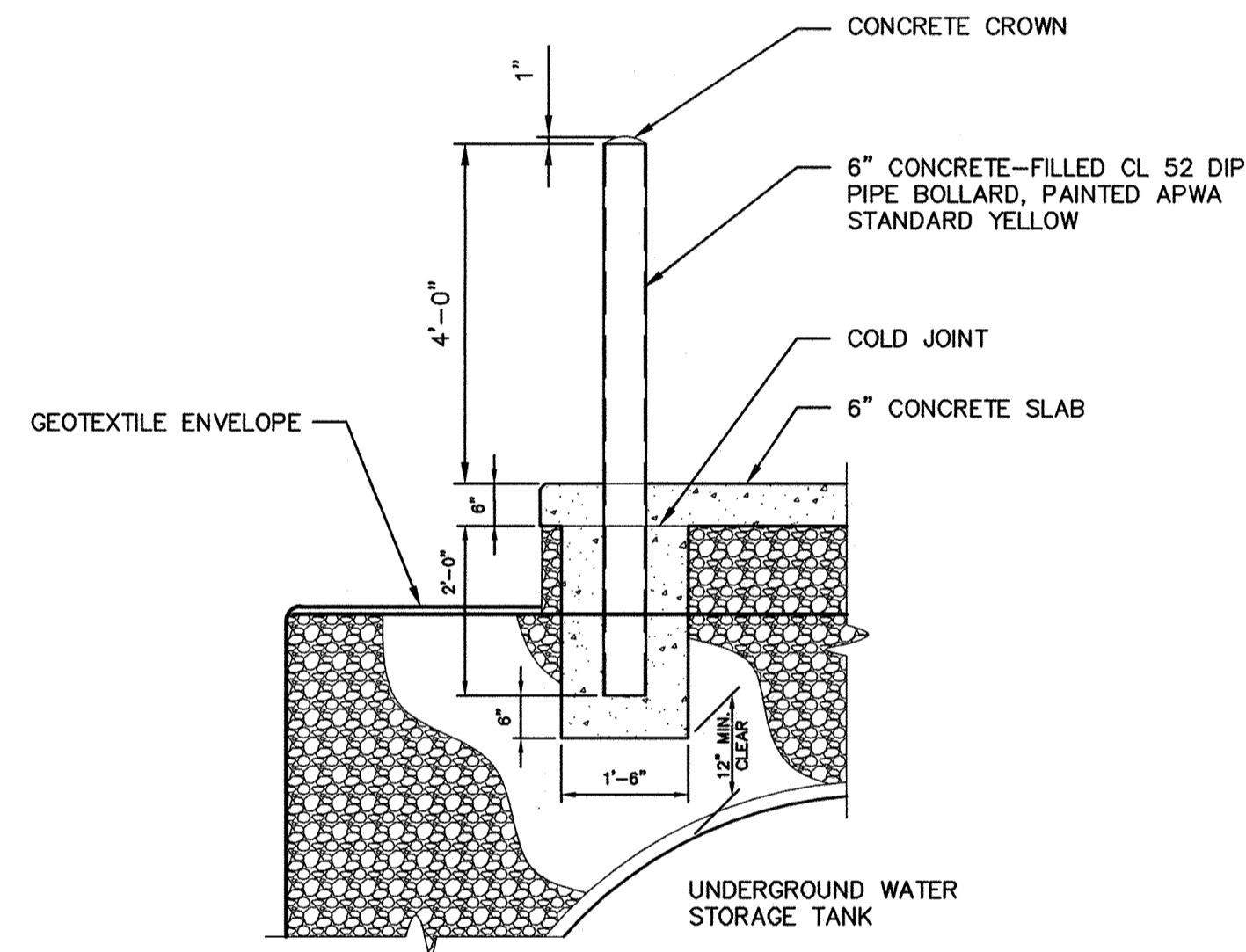

**DETAIL: TYPICAL BOLLARD**  
SCALE: 1/2" = 1'-0"  
(WHEN REQUIRED)

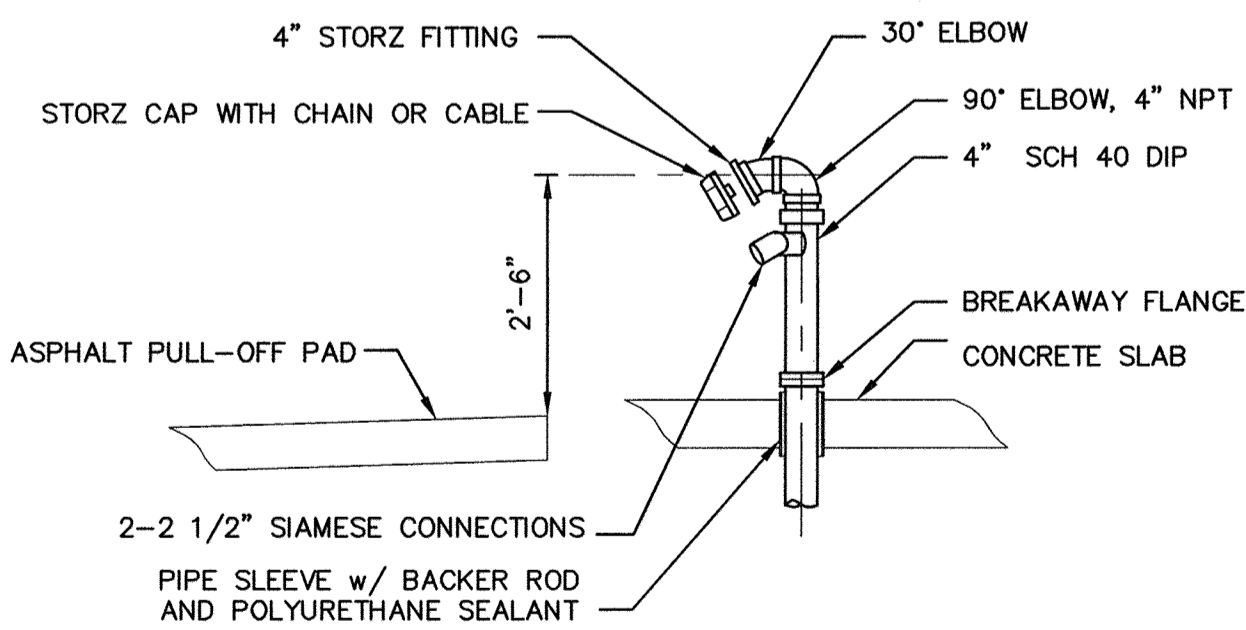

**NOTE:**  
REFER TO SPECIFICATION 2.2.4 - FITTINGS, ON SHEET 2 OF 7

**DETAIL: FILL ASSEMBLY**  
SCALE: 1/2" = 1'-0"

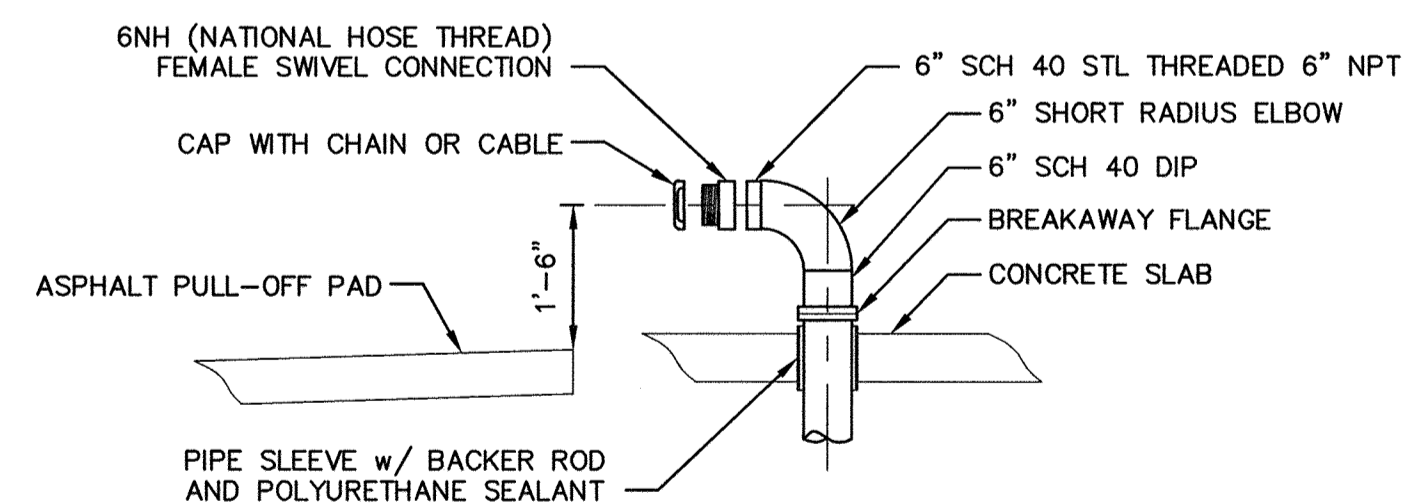

\* PVC FITTINGS WILL NOT BE PERMITTED FOR DRAFT ASSEMBLY

**NOTE:**  
REFER TO SPECIFICATION 2.2.4 - FITTINGS, ON SHEET 2 OF 7

**DETAIL: HYDRANT HEAD (DRAFT) ASSEMBLY**  
SCALE: 1/2" = 1'-0"

FITTING	DESCRIPTION	SPECIFICATION	CENTER DRAFT		END DRAFT	
			SECTION*	OFFSET**	SECTION*	OFFSET**
DRAFT	6" 6NH FEMALE SWIVEL (DIP)	2.2.4.1	16	22'-0"	1	0"
FILL	4" DIP, (2) 2 1/2" FEMALE SIAMESE, AND (1) 4" STORTZ	2.2.4.3	7	8'-2 1/2"	10	12'-4 1/2"
VENT	8" PVC	2.2.4.2	10	12'-4 1/2"	12	16'-6"
MANWAY	36" DIAMETER, 52" COVER	2.2.2	12-14	17'-10 1/2"	5-7	7'-0"

\* SEE ELEVATION ON SHEET 4 FOR SECTION NUMBERING  
\*\* OFFSET FROM CENTER OF SECTION 1

ELEVATION	DESCRIPTION
15'-0" (MAX.)	DRAFT PIPE CENTERLINE
13'-0"	TOP OF SLAB
10'-0"	TOP OF TANK
0	BOTTOM OF TANK
-10"	BOTTOM OF EXCAVATION

FITTING	DESCRIPTION	CENTER DRAFT		END DRAFT	
		SECTION*	OFFSET**	SECTION*	OFFSET**
DRAFT	6" NPT FULL COUPLING	16	22'-0"	1	0"
FILL	4" NPT FULL COUPLING	7	8'-2 1/2"	10	12'-4 1/2"
VENT	10" CLASS 150 FLANGE	10	12'-4 1/2"	12	16'-6"
MANWAY	36" MANWAY, 24" EXTENSION, 4" NPT COUPLING AND PLUG	12-14	17'-10 1/2"	5-7	7'-0"

\* SEE ELEVATION ON SHEET 4 FOR SECTION NUMBERING  
\*\* OFFSET FROM CENTER OF SECTION 1

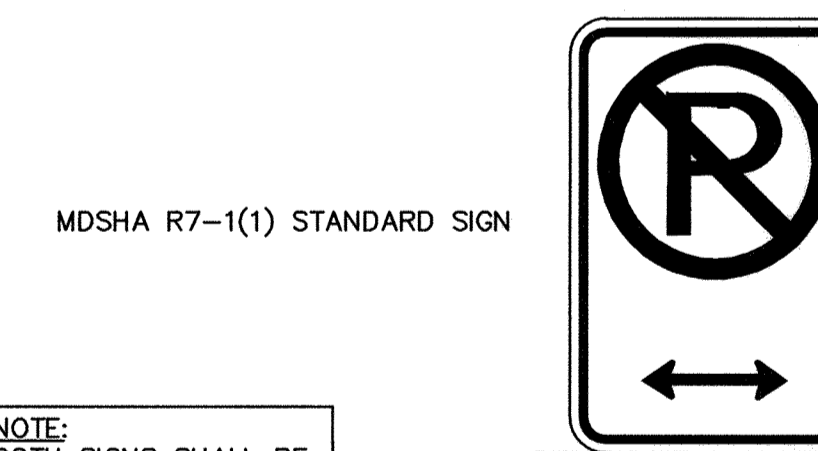

**NOTE:**  
BOTH SIGNS SHALL BE MOUNTED ON A SINGLE POST, IN ACCORDANCE WITH HOWARD COUNTY STANDARD DETAILS

MSHA BLANK STANDARDS HORIZONTAL RECTANGLE 21" X 15"

**DETAIL: TYPICAL TANK SITE SIGNAGE**  
SCALE: 1/2" = 1'-0"



MSHA BLANK STANDARDS HORIZONTAL RECTANGLE 30" X 24"

**DETAIL: TYPICAL ADVANCE SIGNAGE**  
SCALE: 1/2" = 1'-0"

PROFESSIONAL CERTIFICATION I hereby certify that these documents were prepared or approved by me, and that I am a duly licensed professional engineer under the laws of the State of Maryland, License No. 31363, Expiration Date 01/16/2018.

DEPARTMENT OF PUBLIC WORKS  
HOWARD COUNTY, MARYLAND

*[Signature]* 7/16/17  
DIRECTOR OF PUBLIC WORKS DATE  
*[Signature]* 7/10/17  
CHIEF, BUREAU OF UTILITIES DATE

*[Signature]* 7/16/17  
CHIEF, BUREAU OF ENGINEERING DATE  
*[Signature]* 7/16/17  
CHIEF, UTILITY DESIGN DIVISION DATE

ENGINEERS  
PLANNERS  
SCIENTISTS  
CONSTRUCTION MANAGERS  
**KCI TECHNOLOGIES**  
936 Ridgeway Road  
Sparks, MD 21152  
Phone: (410) 316-7800  
Fax: (410) 316-7817  
www.kci.com

STATE OF MARYLAND  
QUIRINA WANG  
PROFESSIONAL ENGINEER  
NO. 31363  
7/10/2017

DES:	KFJ				
DRN:	KFJ				
CHK:	GW				
DATE:	JULY, 2017	BY	NO.	REVISION	DATE

GENERAL DETAILS - 2

UNDERGROUND WATER STORAGE TANKS FOR FIRE SUPPRESSION

CAPITAL PROJECT No. F-5972  
CONTRACT No. 65-4959  
HOWARD COUNTY, MARYLAND

SCALE  
AS SHOWN  
SHEET  
5 OF 7

13122677.38.dwg User: jk Date: 7/16/17 1:30 PM Plot Date: 7/16/17 1:30 PM Plot Path: C:\Users\jk\AppData\Local\Temp\13122677.38.dwg

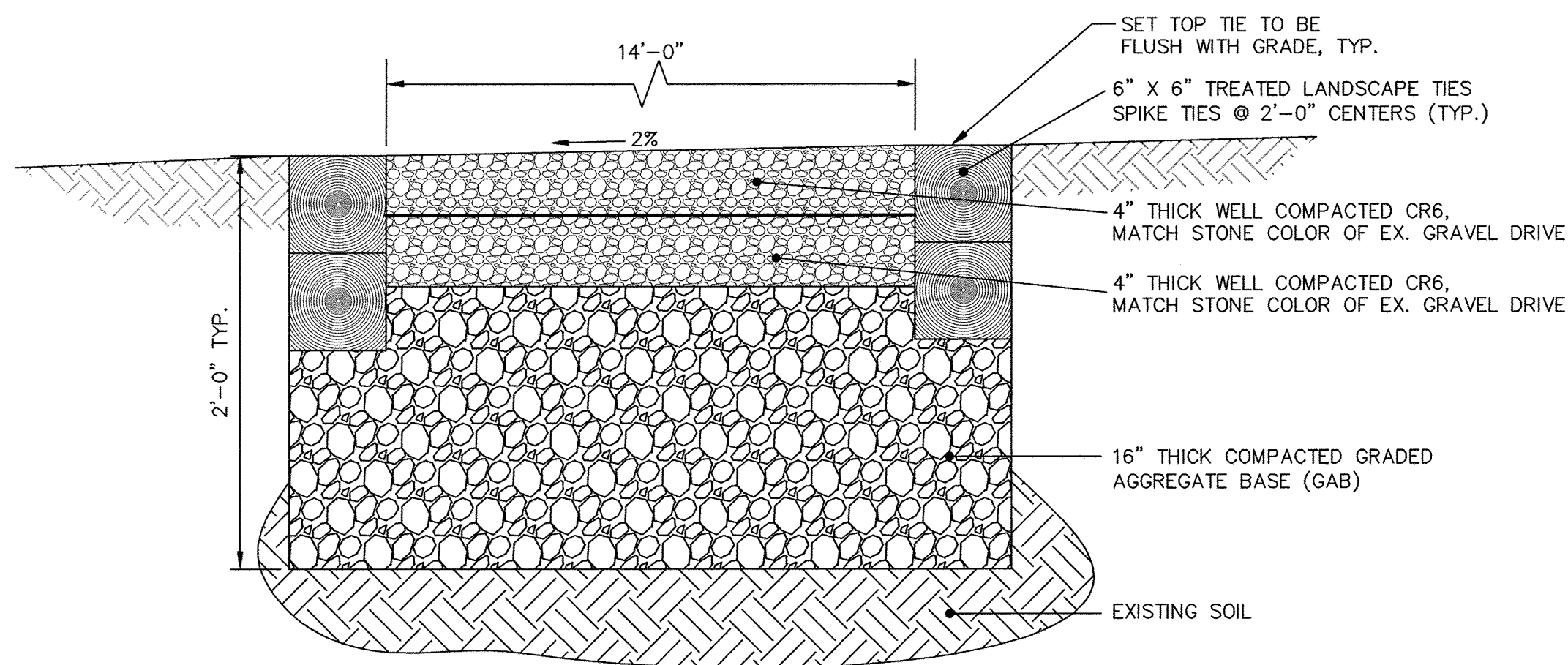

**DETAIL: SPECIAL PAVING SECTION**  
SCALE: NOT TO SCALE

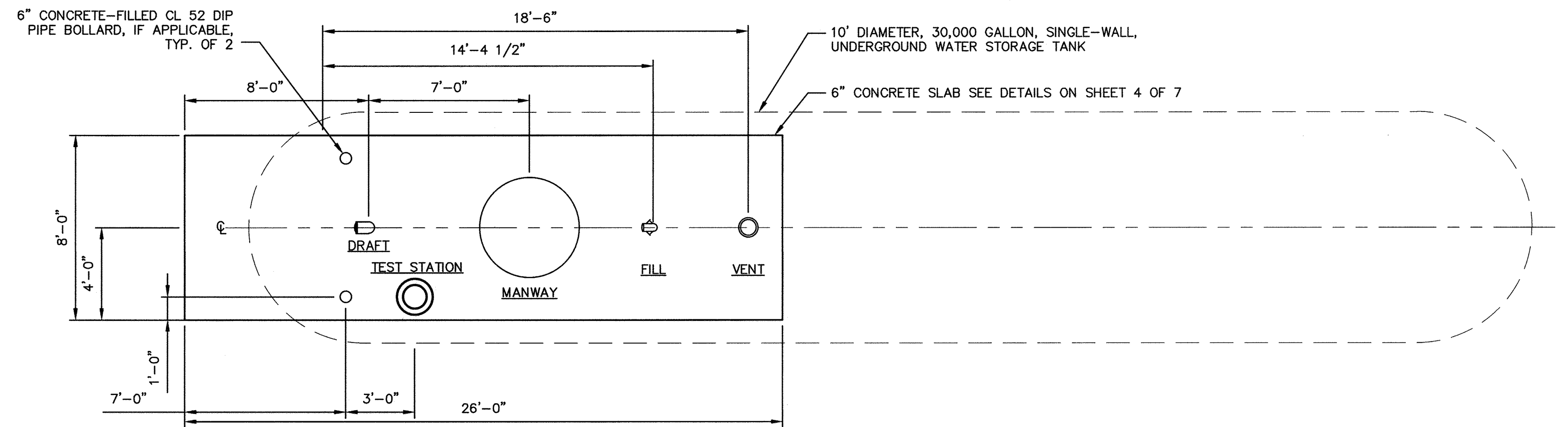

**PLAN: 30,000 GALLON FIRE SUPPRESSION WATER STORAGE TANK, END-DRAFT CONFIGURATION**  
SCALE: 1/4" = 1'-0"

**NOTE:**  
BOLLARDS SHALL ONLY BE INSTALLED AT THE DIRECTION OF HOWARD COUNTY.

**NOTE:**  
TANK DIMENSIONS AND LAYOUT ARE FOR REFERENCE ONLY. ACTUAL TANK DIMENSIONS WILL VARY WITH MANUFACTURER.

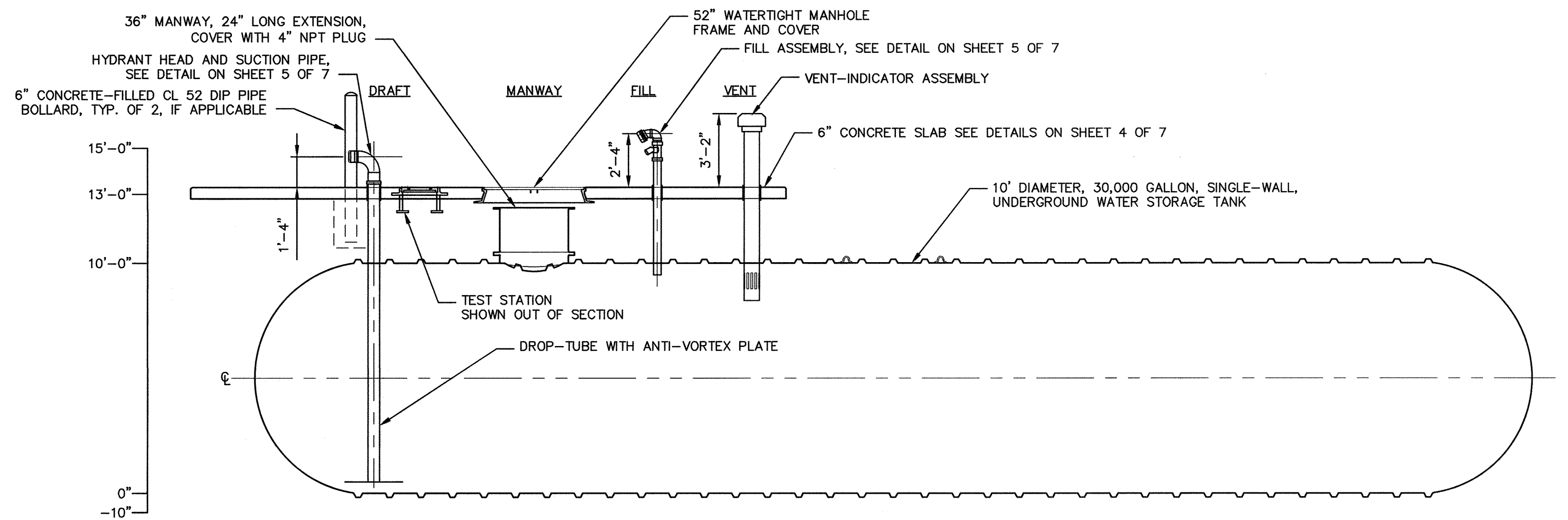

**SECTION THROUGH 30,000 GALLON FIRE SUPPRESSION WATER STORAGE TANK, END-DRAFT CONFIGURATION**  
SCALE: 1/4" = 1'-0"

PROFESSIONAL CERTIFICATION: I hereby certify that these documents were prepared or approved by me, and that I am a duly licensed professional engineer under the laws of the State of Maryland, License No. 31363, Expiration Date 01/16/2018.

DEPARTMENT OF PUBLIC WORKS HOWARD COUNTY, MARYLAND		
Director of Public Works <i>[Signature]</i>	Chief, Bureau of Engineering <i>[Signature]</i>	936 Rtegetbrook Road Sparks, MD 21152 Phone: (410) 316-7800 Fax: (410) 316-7817 www.kci.com
Chief, Bureau of Utilities <i>[Signature]</i>	Chief, Utility Design Division <i>[Signature]</i>	STATE OF MARYLAND PROFESSIONAL ENGINEER NO. 31363 7/10/2017

DES: KFJ					
DRN: KFJ					
CHK: GW					
DATE: JULY, 2017	BY	NO.	REVISION	DATE	

**GENERAL DETAILS - 3**

**UNDERGROUND WATER STORAGE TANKS FOR FIRE SUPPRESSION**  
 CAPITAL PROJECT No. F-5972  
 CONTRACT No. 65-4959  
 HOWARD COUNTY, MARYLAND

SCALE AS SHOWN  
 SHEET 6 OF 7

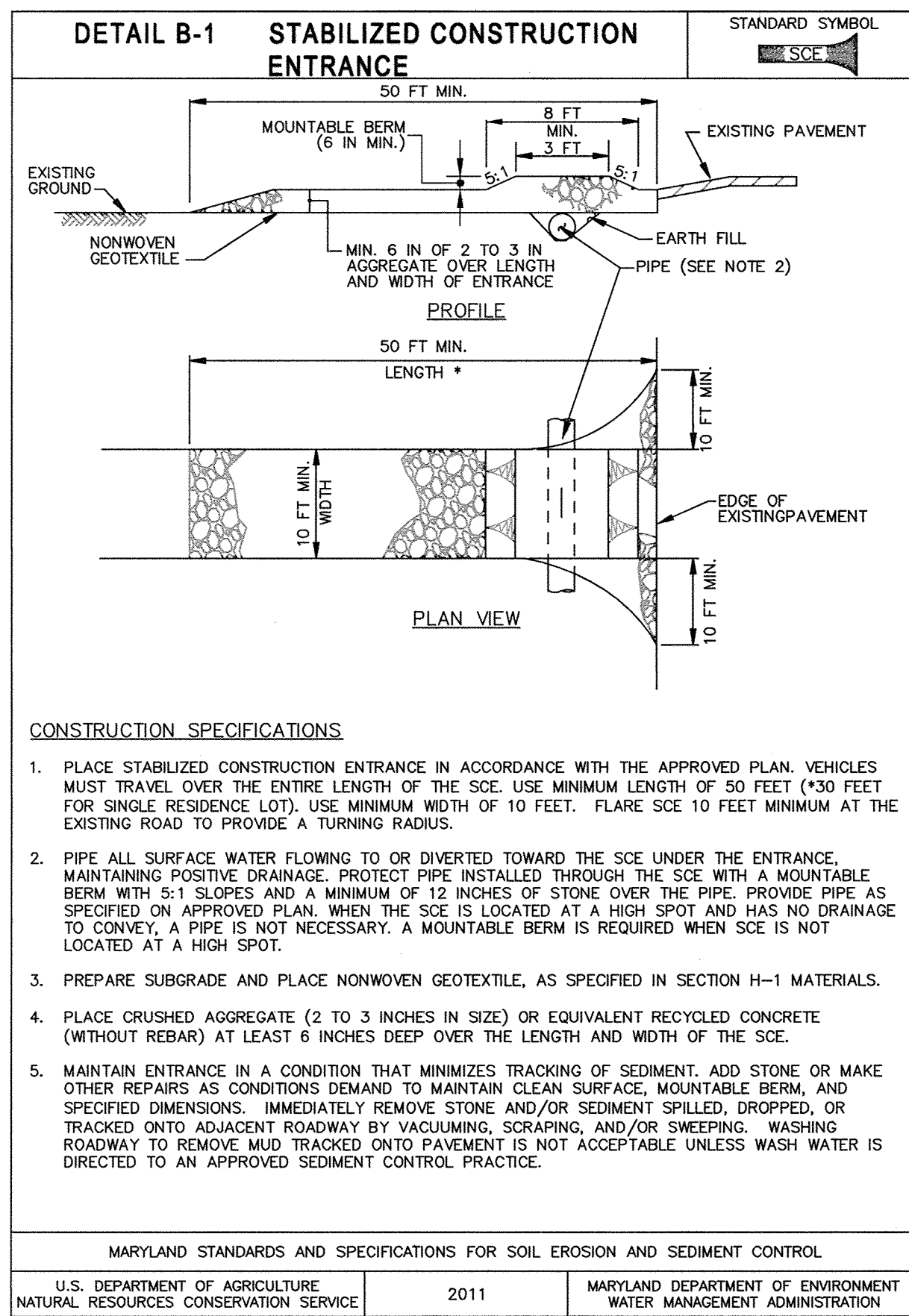
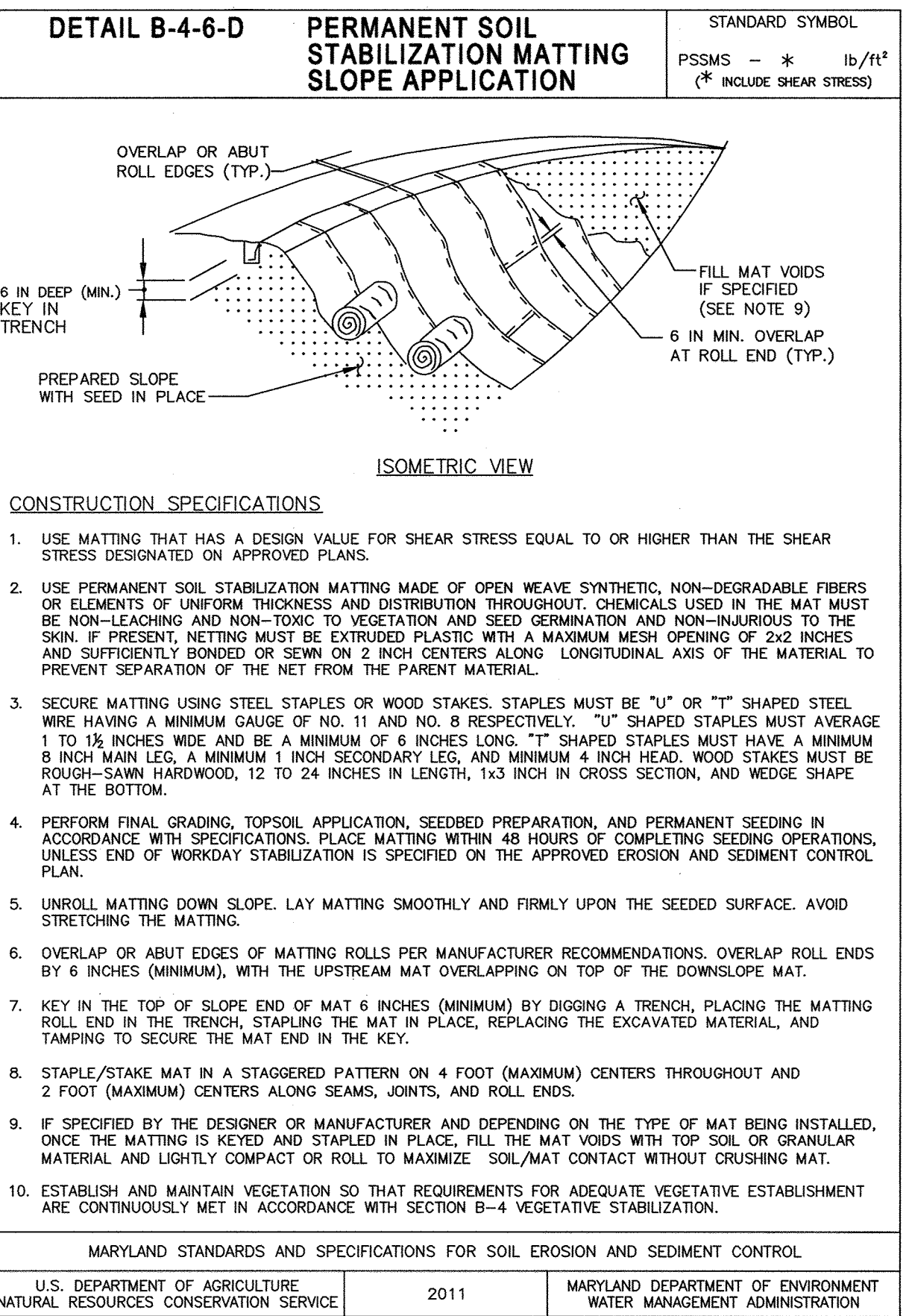
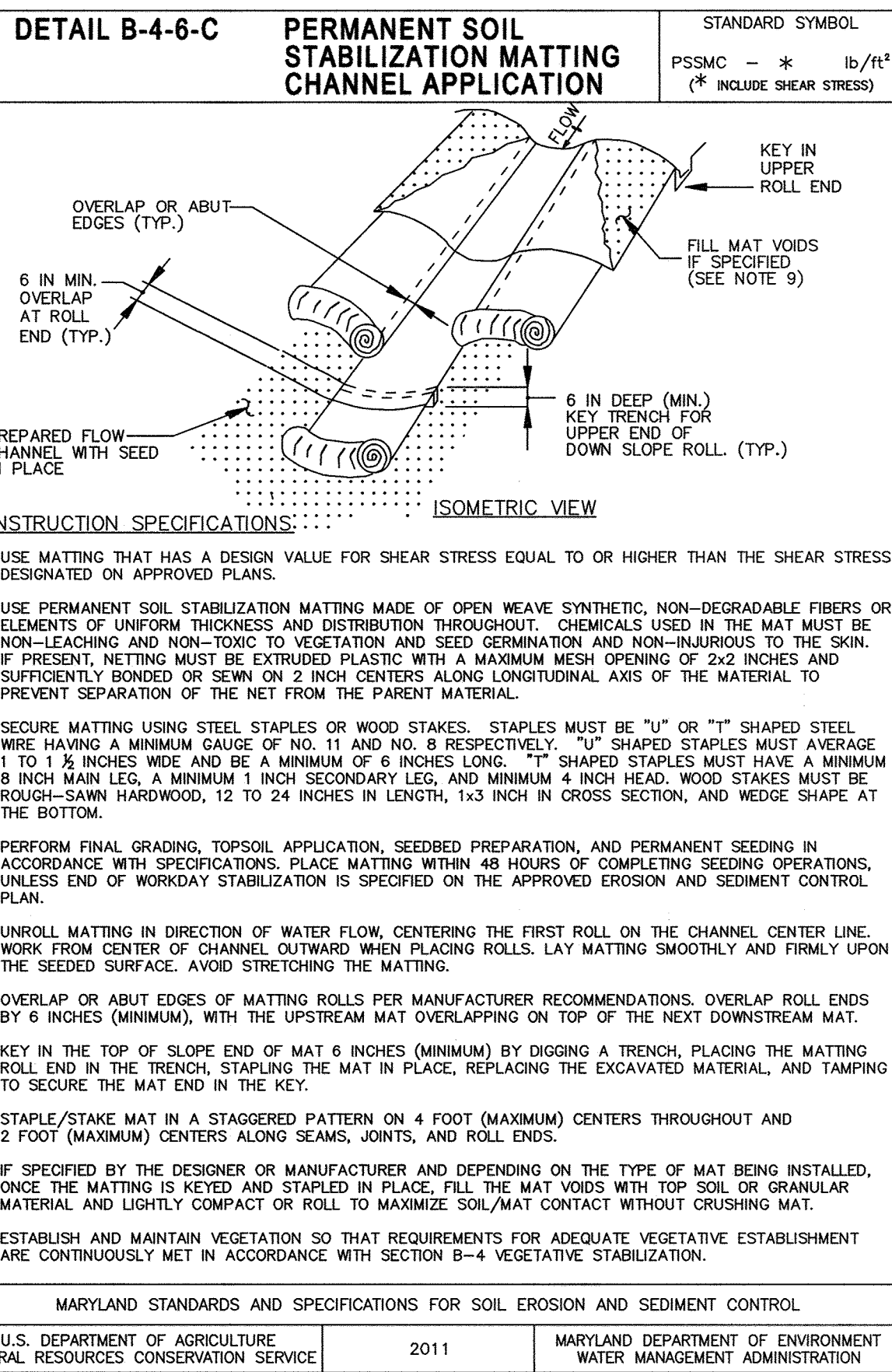
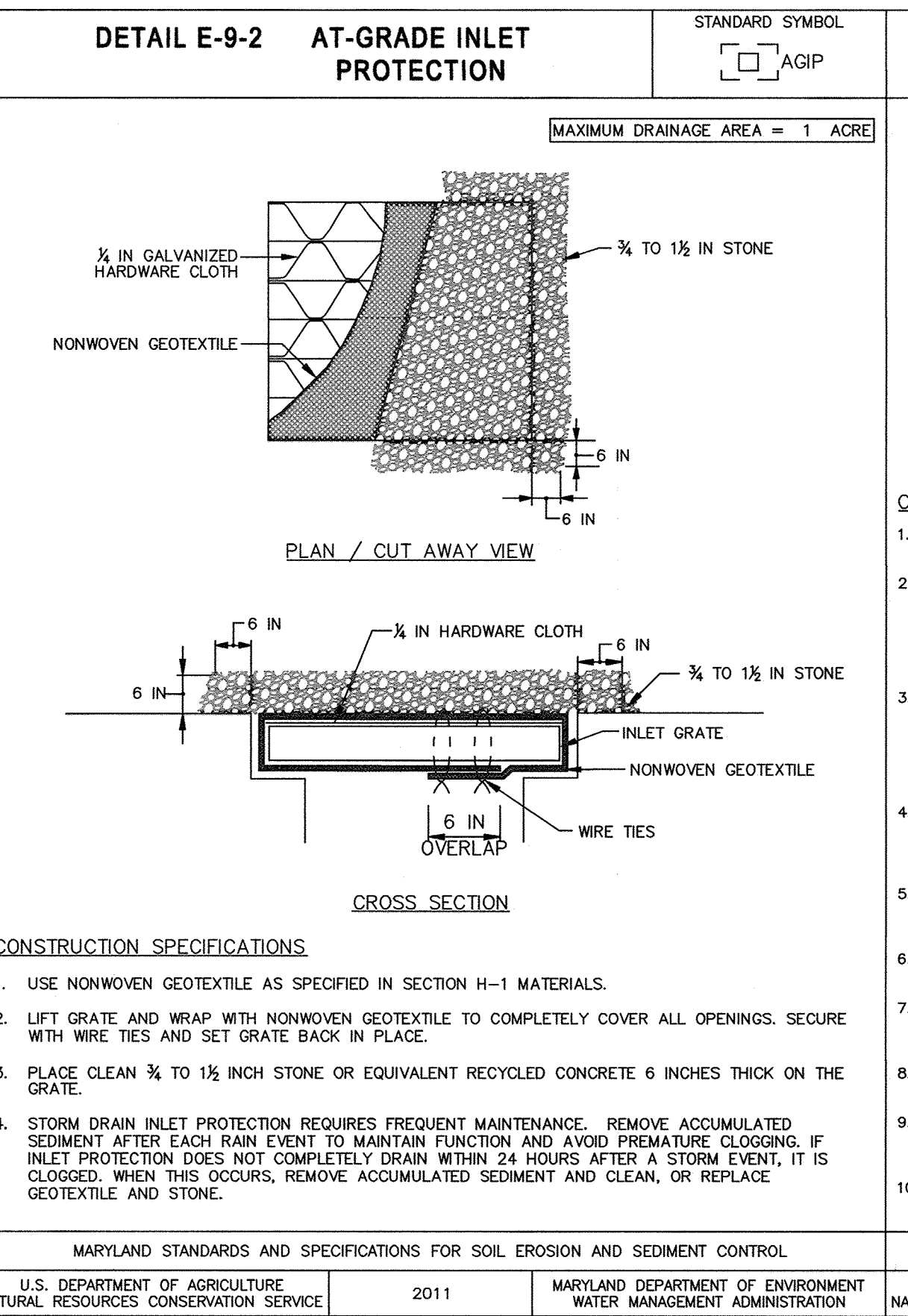
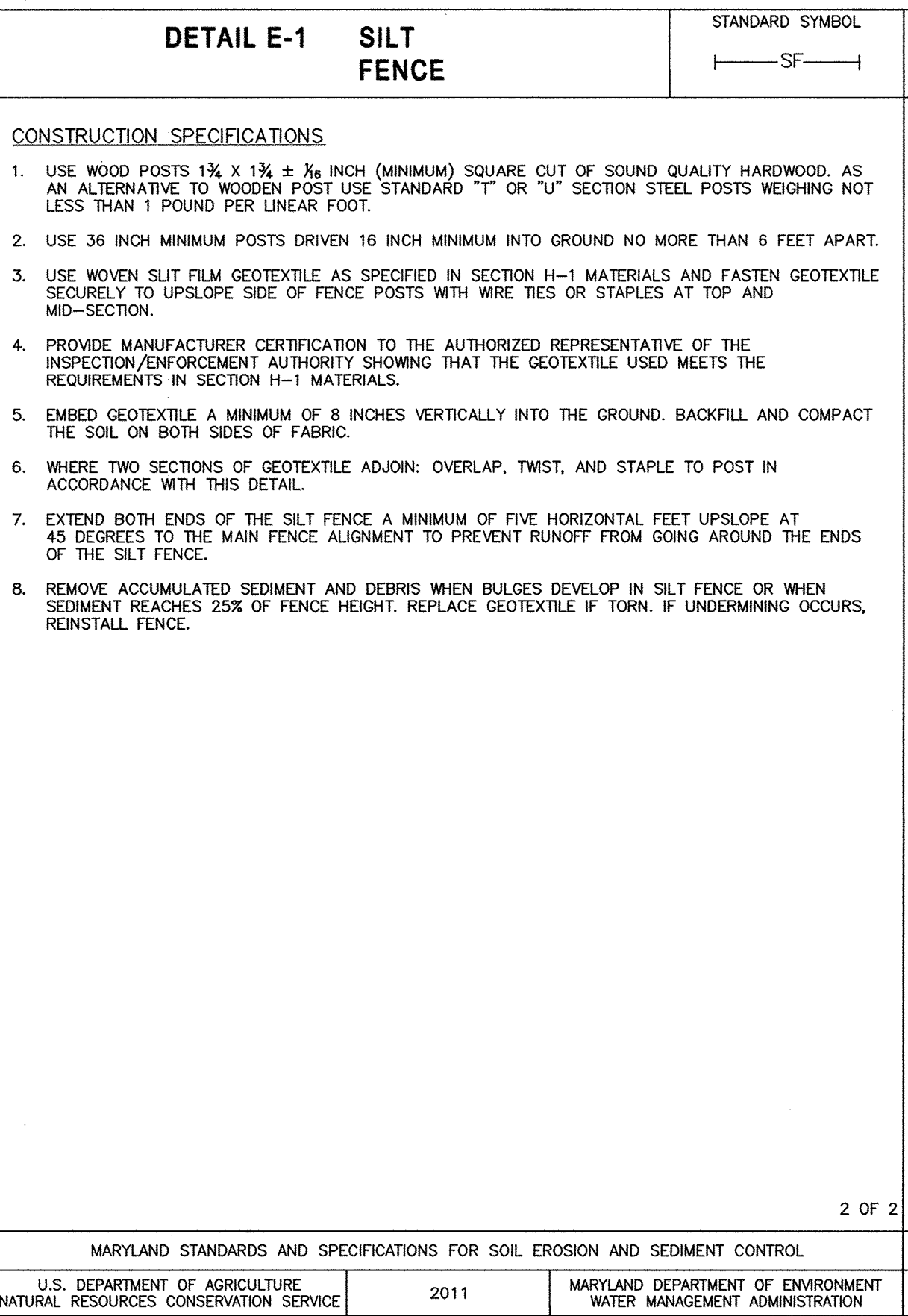
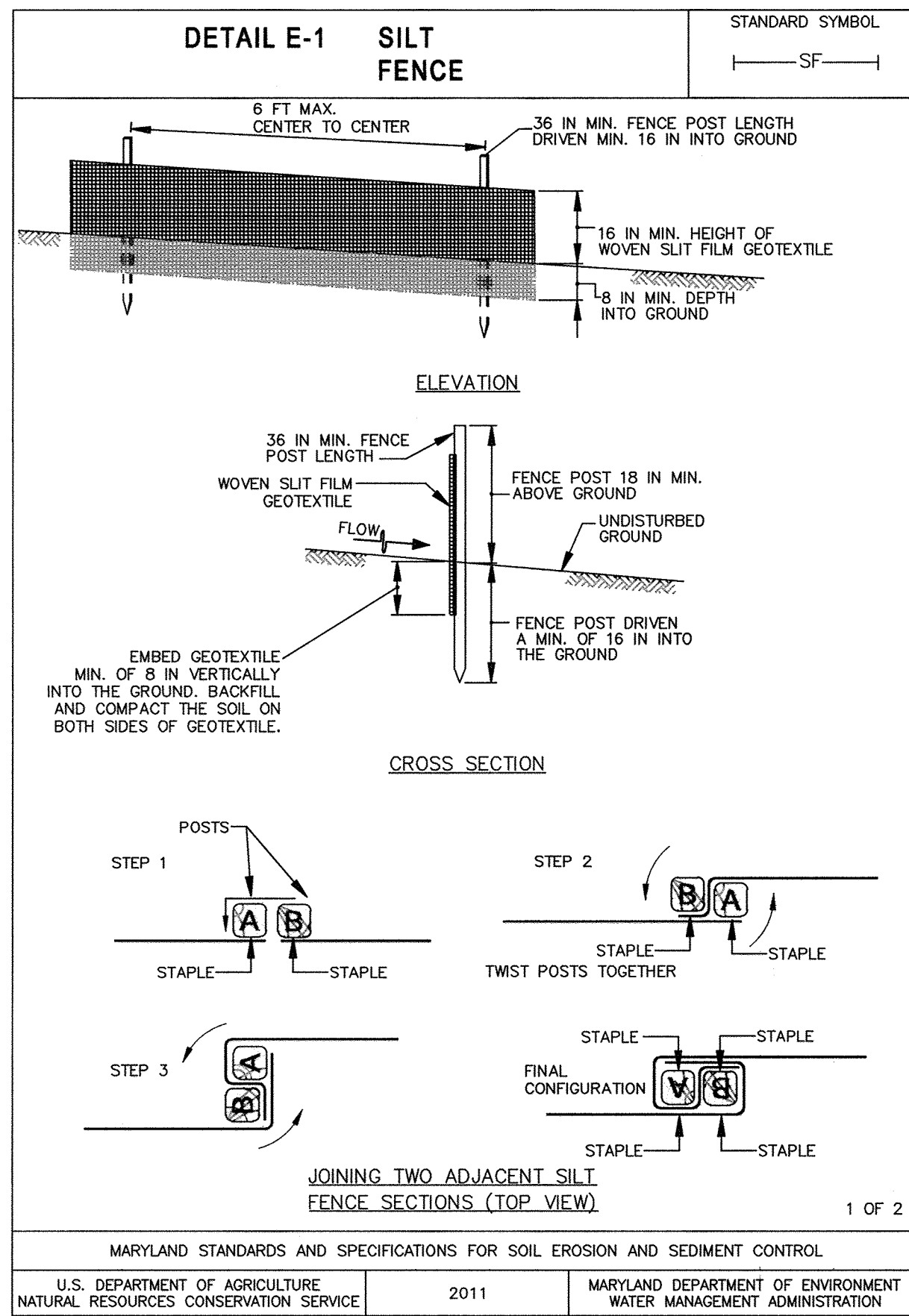

### STANDARD SEDIMENT CONTROL NOTES

- A MINIMUM OF 48 HOURS NOTICE MUST BE GIVEN TO THE CHARLES COUNTY DEPARTMENT OF INSPECTIONS, LICENSES AND PERMITS, SEDIMENT CONTROL DIVISION (301-645-0700) PRIOR TO THE START OF ANY CONSTRUCTION.
- ALL VEGETATIVE AND STRUCTURAL PRACTICES ARE TO BE INSTALLED ACCORDING TO THE PROVISIONS OF THIS PLAN AND ARE TO BE IN CONFORMANCE WITH THE MOST CURRENT 'MARYLAND STANDARDS AND SPECIFICATIONS FOR SOIL EROSION AND SEDIMENT CONTROL', AND REVISIONS THERETO.
- FOLLOWING INITIAL SOIL DISTURBANCE OR RE-DISTURBANCE, SEEDING FOR PERMANENT OR TEMPORARY STABILIZATION SHALL BE COMPLETED WITHIN THREE (3) CALENDAR DAYS AS TO THE SURFACE OF ALL PERIMETER CONTROLS, DIKES, SWALES, DITCHES, PERIMETER SLOPES AND ALL SLOPES GREATER THAN 3 HORIZONTAL TO 1 VERTICAL (3:1); AND SEVEN (7) CALENDAR DAYS AS TO ALL OTHER DISTURBED OR GRADED AREAS ON THE PROJECT SITE NOT UNDER ACTIVE GRADING. ONCE VEGETATION IS ESTABLISHED, THE SITE SHALL HAVE 95% GROUND COVER TO BE CONSIDERED ADEQUATELY STABILIZED.
- ALL SEDIMENT TRAPS/BASINS SHOWN MUST BE FENCED AND WARNING SIGNS POSTED AROUND THEIR PERIMETER IN ACCORDANCE WITH CHARLES COUNTY STANDARD SPECIFICATIONS.
- ALL DISTURBED AREAS MUST BE STABILIZED WITHIN THE TIME PERIOD SPECIFIED ABOVE IN ACCORDANCE WITH THE 2011 MARYLAND STANDARDS AND SPECIFICATIONS FOR SOIL EROSION AND SEDIMENT CONTROL (SEC. G2.0.) FOR PERMANENT SEEDINGS, SOD, TEMPORARY SEEDING AND MULCHING. TEMPORARY STABILIZATION WITH MULCH ALONE CAN ONLY BE DONE WHEN RECOMMENDED SEEDING DATES DO NOT ALLOW FOR PROPER GERMINATION AND ESTABLISHMENT OF GRASSES.
- ALL SEDIMENT CONTROL STRUCTURES ARE TO REMAIN IN PLACE AND ARE TO BE MAINTAINED IN OPERATIVE CONDITION UNTIL PERMISSION FOR THEIR REMOVAL HAS BEEN OBTAINED FROM THE CHARLES SEDIMENT CONTROL INSPECTOR.
- SITE ANALYSIS:

TOTAL AREA OF SITE	SEE SITE PLANS	ACRES
AREA DISTURBED	SEE SITE PLANS	ACRES
AREA TO BE ROOFED OR PAVED	SEE SITE PLANS	ACRES
AREA TO BE VEGETATIVELY STABILIZED	SEE SITE PLANS	ACRES
TOTAL CUT	SEE SITE PLANS	CU.YDS.
TOTAL FILL	SEE SITE PLANS	CU.YDS.
ONSITE WASTE/BORROW AREA LOCATION	SEE SITE PLANS	ACRES
- ANY SEDIMENT CONTROL PRACTICE WHICH IS DISTURBED BY GRADING ACTIVITY FOR PLACEMENT OF UTILITIES MUST BE REPAIRED ON THE SAME DAY OF THE DISTURBANCE.
- ADDITIONAL SEDIMENT CONTROLS MUST BE PROVIDED, IF DEEMED NECESSARY BY THE CHARLES SEDIMENT CONTROL INSPECTOR.
- ON ALL SITES WITH DISTURBED AREAS IN EXCESS OF 2 ACRES, APPROVAL OF THE INSPECTION AGENCY SHALL BE REQUESTED UPON COMPLETION OF INSTALLATION OF PERIMETER EROSION AND SEDIMENT CONTROLS, BUT BEFORE PROCEEDING WITH ANY OTHER EARTH DISTURBANCE OR GRADING. OTHER BUILDING OR GRADING INSPECTION APPROVALS MAY NOT BE AUTHORIZED UNTIL THIS INITIAL APPROVAL BY THE INSPECTION AGENCY IS MADE.
- TRENCHES FOR THE CONSTRUCTION OF UTILITIES IS LIMITED TO THREE (3) PIPE LENGTHS OR THAT WHICH CAN BE BACK FILLED AND STABILIZED WITHIN ONE WORKING DAY, WHICHEVER IS SHORTER.
- CONTRACTOR SHALL PLACE EXCAVATED MATERIALS ON UPHILL SIDE OF TRENCH AND PLACE SILT FENCE ON DOWNHILL SIDE OF TRENCH.
- ALL SITES WHERE SEDIMENT AND EROSION CONTROL DEVICES ARE INSTALLED SHALL BE RESTORED THE SAME DAY THAT SUCH DEVICES ARE REMOVED.

### PERMANENT SEEDING NOTES

APPLY TO GRADED OR CLEARED AREAS NOT SUBJECT TO IMMEDIATE FURTHER DISTURBANCE WHERE A PERMANENT LONG-LIVED VEGETATIVE COVER IS NEEDED.

SEEDBED PREPARATION: LOOSEN UPPER THREE INCHES OF SOIL BY RAKING, DISKING OR OTHER ACCEPTABLE MEANS BEFORE SEEDING, IF NOT PREVIOUSLY LOOSENED.

SOIL AMENDMENTS: IN LIEU OF SOIL TEST RECOMMENDATIONS, USE ONE OF THE FOLLOWING SCHEDULES:

- PREFERRED - APPLY 2 TONS PER ACRES DOLOMITIC LIMESTONE (92 LBS/1000 SQ FT.) AND 600 LBS PER ACRE 10-10-10 FERTILIZER (14 LBS/1000 SQ FT.) BEFORE SEEDING. HARROW OR DISK INTO UPPER THREE INCHES OF SOIL. AT TIME OF SEEDING, APPLY 400 LBS PER ACRE 30-0-0 UREAFORM FERTILIZER (9 LBS/1000 SQ FT.).
- ACCEPTABLE - APPLY 2 TONS PER ACRE DOLOMITIC LIMESTONE (92 LBS/1000 SQ FT.) AND 1000 LBS PER ACRE 10-10-10 FERTILIZER (23 LBS/1000 SQ FT.) BEFORE SEEDING. HARROW OR DISK INTO UPPER THREE INCHES OF SOIL.

SEEDING - FOR THE PERIODS MARCH 1 THRU APRIL 30, AND AUGUST 1 THRU OCTOBER 15, SEED WITH 60 LBS PER ACRE (1.4 LBS/1000 SQ FT.) OF KENTUCKY 31 TALL FESCUE. FOR THE PERIOD MAY 1 THRU JULY 31, SEED WITH 60 LBS KENTUCKY 31 TALL FESCUE PER ACRE AND 2 LBS PER ACRE (0.5 LBS/1000 SQ FT.) OF WEeping LOVEGRASS. DURING THE PERIOD OF OCTOBER 16 THRU FEBRUARY 28, PROTECT SITE BY: OPTION (1) 2 TONS PER ACRE OF WELL ANCHORED STRAW MULCH AND SEED AS SOON AS POSSIBLE IN THE SPRING. OPTION (2) USE SOD. OPTION (3) SEED WITH 60 LBS/ACRE KENTUCKY 31 TALL FESCUE AND MULCH WITH 2 TONS/ACRE WELL ANCHORED STRAW.

MULCHING - APPLY 1-1/2 TO 2 TONS PER ACRE (70 TO 90 LBS/1000 SQ FT.) OF UNROTATED SMALL GRAIN STRAW IMMEDIATELY AFTER SEEDING. ANCHOR MULCH IMMEDIATELY AFTER APPLICATION USING MULCH ANCHORING TOOL OR 218 GALLONS PER ACRE (5 GAL/1000 SQ FT.) OF EMULSIFIED ASPHALT ON FLAT AREAS. ON SLOPES 8 FEET OR HIGHER, USE 348 GALLONS PER ACRE (8 GAL/1000 SQ FT.) FOR ANCHORING.

MAINTENANCE - INSPECT ALL SEEDED AREAS AND MAKE NEEDED REPAIRS, REPLACEMENTS AND RESEEDINGS.

### TEMPORARY SEEDING NOTES

APPLY TO GRADED OR CLEARED AREAS LIKELY TO BE REDISTURBED WHERE A SHORT-TERM VEGETATIVE COVER IS NEEDED.

SEEDBED PREPARATION: LOOSEN UPPER THREE INCHES OF SOIL BY RAKING, DISKING OR OTHER ACCEPTABLE MEANS BEFORE SEEDING, IF NOT PREVIOUSLY LOOSENED.

SOIL AMENDMENTS: - APPLY 600 LBS PER ACRE 10-10-10 FERTILIZER (14 LBS/1000 SQ FT.).

SEEDING - FOR PERIODS MARCH 1 THRU APRIL 30 AND FROM AUGUST 15 THRU OCTOBER 15, SEED WITH 2-1/2 BUSHEL PER ACRE OF ANNUAL RYE (3.2 LBS/1000 SQ FT.). FOR THE PERIOD MAY 1 THRU AUGUST 14, SEED WITH 3 LBS PER ACRE OF WEeping LOVEGRASS (0.7 LBS/1000 SQ FT.). FOR THE PERIOD NOVEMBER 16 THRU FEBRUARY 28, PROTECT SITE BY APPLYING 2 TONS PER ACRE OF WELL ANCHORED STRAW MULCH AND SEED AS SOON AS POSSIBLE IN THE SPRING, OR USE SOD.

MULCHING - APPLY 1-1/2 TO 2 TONS PER ACRE (70 TO 90 LBS/1000 SQ FT.) OF UNROTATED SMALL GRAIN STRAW IMMEDIATELY AFTER SEEDING. ANCHOR MULCH IMMEDIATELY AFTER APPLICATION USING MULCH ANCHORING TOOL OR 218 GAL PER ACRE (5 GAL/1000 SQ FT.) OF EMULSIFIED ASPHALT ON FLAT AREAS. ON SLOPES 8 FT OR HIGHER, USE 348 GAL PER ACRE (8 GAL/1000 SQ FT.) FOR ANCHORING.

REFER TO THE 2011 MARYLAND STANDARDS AND SPECIFICATIONS FOR SOIL EROSION AND SEDIMENT CONTROL FOR RATE AND METHODS NOT COVERED.

### SEQUENCE OF CONSTRUCTION

- INSTALL SEDIMENT CONTROL DEVICES AS SHOWN ON SITE PLAN, (1 DAY).
- INLET PROTECTION SHALL BE INSTALLED ON INLETS DOWN GRADE OF THE SITE.
- ROADS AND STREETS SHALL BE KEPT BROOM CLEAN AT ALL TIMES.
- SITE EXCAVATION AND GRADING, (3 DAYS). SITE STAGING AND STOCK-PILE AREAS.
- EXCAVATE FOR TANK (2 DAYS).
- INSTALL TANK ACCORDING TO PLAN AND DETAILS. (3 DAYS)
- BACKFILL AROUND TANK, (1 DAY).
- INSTALL CONCRETE SLAB ACCORDING TO PLAN AND DETAILS. (5 DAYS)
- INSTALL ASPHALT PULLOFF ACCORDING TO PLAN AND DETAILS. (2 DAYS)
- PERFORM FINAL GRADING, SEEDING AND LANDSCAPING, (1 DAY).
- REMOVE SEDIMENT CONTROL DEVICES AFTER PERMISSION IS GRANTED BY SEDIMENT CONTROL INSPECTOR, (2 DAYS).

### BEST MANAGEMENT PRACTICES FOR WORKING IN NONTIDAL WETLANDS, WETLAND BUFFERS, WATERWAYS, AND 100-YEAR FLOODPLAINS

- No excess fill, construction material, or debris shall be stockpiled or stored in nontidal wetlands, nontidal wetland buffers, waterways, or the 100-year floodplain.
- Place materials in a location and manner which does not adversely impact surface or subsurface water flow into or out of nontidal wetlands, nontidal wetland buffers, waterways, or the 100-year floodplain.
- Do not use the excavated material as backfill if it contains waste metal products, unsightly debris, toxic material, or any other deleterious substance. If additional backfill is required, use clean material free of waste metal products, unsightly debris, toxic material, or any other deleterious substance.
- Place heavy equipment on mats or suitably operate the equipment to prevent damage to nontidal wetlands, nontidal wetland buffers, waterways, or the 100-year floodplain.
- Repair and maintain any serviceable structure or fill so there is no permanent loss of nontidal wetlands, nontidal wetland buffers, or waterways, or permanent modification of the 100-year floodplain in excess of that lost under the originally authorized structure or fill.
- Rectify any nontidal wetlands, wetland buffers, waterways, or 100-year floodplain temporarily impacted by any construction.
- All stabilization in the nontidal wetland and nontidal wetland buffer shall consist of the following species: Annual Ryegrass (*Lolium multiflorum*), Millet (*Setaria italica*), Barley (*Hordeum sp.*), Oats (*Lolium sp.*), and/or Rye (*Sesale cereale*). These species will allow for the stabilization of the site while also allowing for the voluntary revegetation of natural wetland species. Other non-persistent vegetation may be acceptable, but must be approved by the Nontidal Wetlands and Waterways Division. Kentucky 31 fescue shall not be utilized in wetland or buffer areas. The area should be seeded and mulched to reduce erosion after construction activities have been completed.
- After installation has been completed, make post-construction grades and elevations the same as the original grades and elevations in temporarily impacted areas.
- To protect aquatic species, in-stream work is prohibited as determined by the classification of the stream:
  - Use I waters: In-stream work shall not be conducted during the period March 1 through June 15, inclusive, during any year.
  - Use III waters: In-stream work shall not be conducted during the period October 1 through April 30, inclusive, during any year.
  - Use IV waters: In-stream work shall not be conducted during the period March 1 through May 31, inclusive, during any year.
- Stormwater runoff from impervious surfaces shall be controlled to prevent the washing of debris into the waterway.
- Culverts shall be constructed and any riprap placed so as not to obstruct the movement of aquatic species, unless the purpose of the activity is to impound water.

<b>DEPARTMENT OF PUBLIC WORKS</b> HOWARD COUNTY, MARYLAND			
<i>[Signature]</i> DIRECTOR OF PUBLIC WORKS DATE: 7/20/17	<i>[Signature]</i> CHIEF, BUREAU OF ENGINEERING DATE: 7/18/17	<i>[Signature]</i> CHIEF, BUREAU OF UTILITIES DATE: 7/20/17	<i>[Signature]</i> CHIEF, UTILITY DESIGN DIVISION DATE: 7/18/17

ENGINEERS  
PLANNERS  
SCIENTISTS  
CONSTRUCTION MANAGERS

936 Ridgebrook Road  
Sparks, MD 21152  
Phone: (410) 316-7800  
Fax: (410) 316-7817  
www.kci.com

7/10/2017

DES: Kfj				
DRN: Kfj				
CHK: GW				
DATE: JULY, 2017	BY	NO.	REVISION	DATE

<b>SEDIMENT AND EROSION CONTROL NOTES AND DETAILS</b>	<b>UNDERGROUND WATER STORAGE TANKS FOR FIRE SUPPRESSION</b>	SCALE	AS SHOWN
		SHEET	1 OF 2
		CAPITAL PROJECT No. F-5972 CONTRACT No. 65-4959 HOWARD COUNTY, MARYLAND	

PROFESSIONAL CERTIFICATION: I hereby certify that these documents were prepared or approved by me, and that I am a duly licensed professional engineer under the laws of the State of Maryland, License No. 31363. Expiration Date 01/16/2018.

KCI TECHNOLOGIES PROJECT No.: 13122677.3B

STAKEOUT TABLE			
DESCRIPTION	NORTHING	EASTING	ELEV
TRAV 1 (REBAR AND CAP)	596069.77	1302264.46	582.28
TRAV 14E1 (HO. CO. TRAVERSE)	596213.61	1301991.96	590.00
BORING B-1	596207.51	1302080.34	589.50
BORING B-2	596228.61	1302061.94	590.33
NW CORNER ASPHALT PULLOFF	596266.98	1302064.05	590.41
NE CORNER ASPHALT PULLOFF	596199.61	1302122.78	588.06
SW CORNER ASPHALT PULLOFF	596259.91	1302055.97	590.44
SE CORNER ASPHALT PULLOFF	596190.49	1302112.33	588.21
NW CORNER CONCRETE SLAB	596225.34	1302075.41	589.76
NE CORNER CONCRETE SLAB	596210.26	1302088.55	589.19
SW CORNER CONCRETE SLAB	596217.45	1302066.37	589.90
SE CORNER CONCRETE SLAB	596202.38	1302079.51	589.90
CENTER OF TANK MANWAY	596214.43	1302074.31	589.90

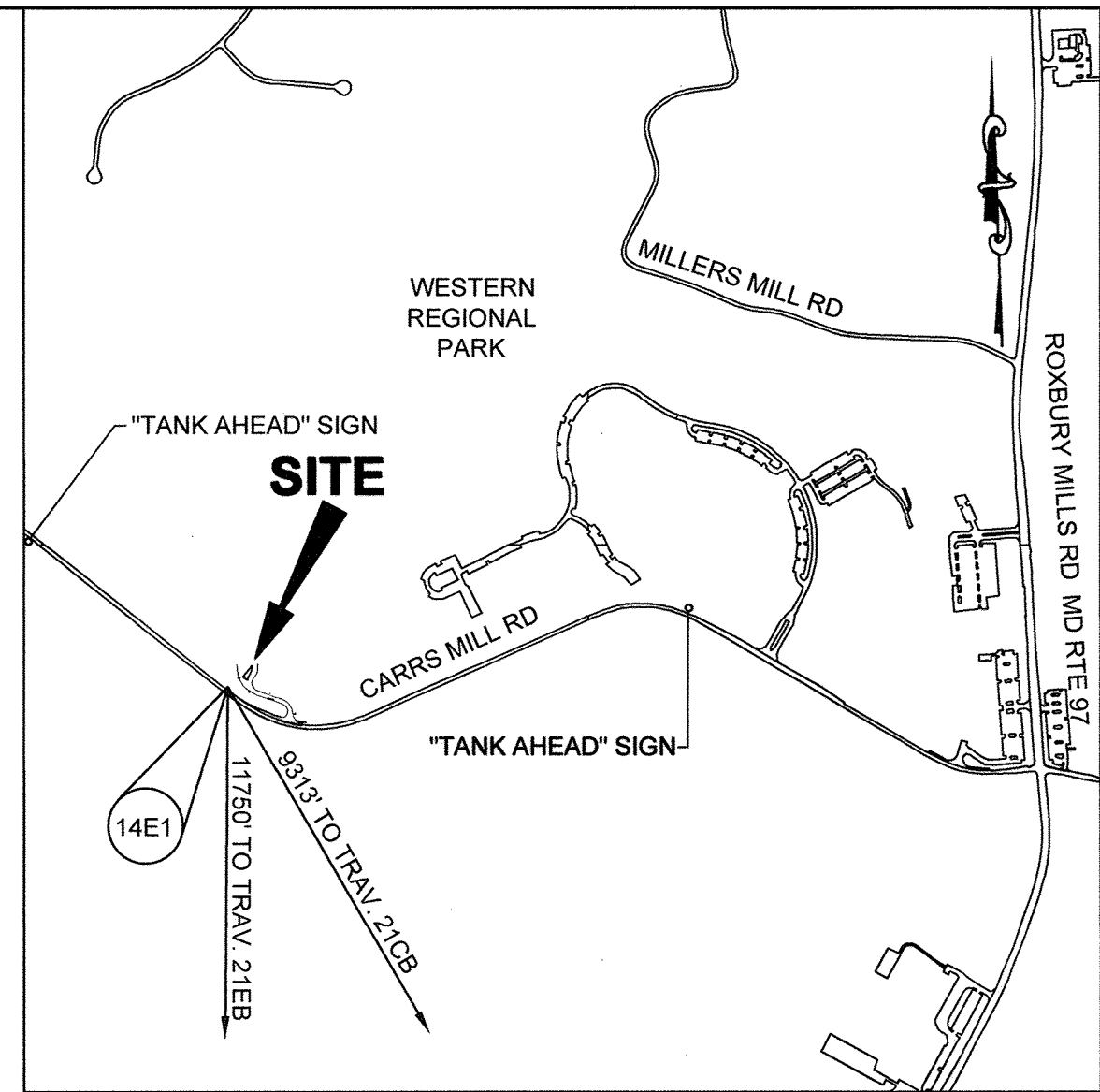
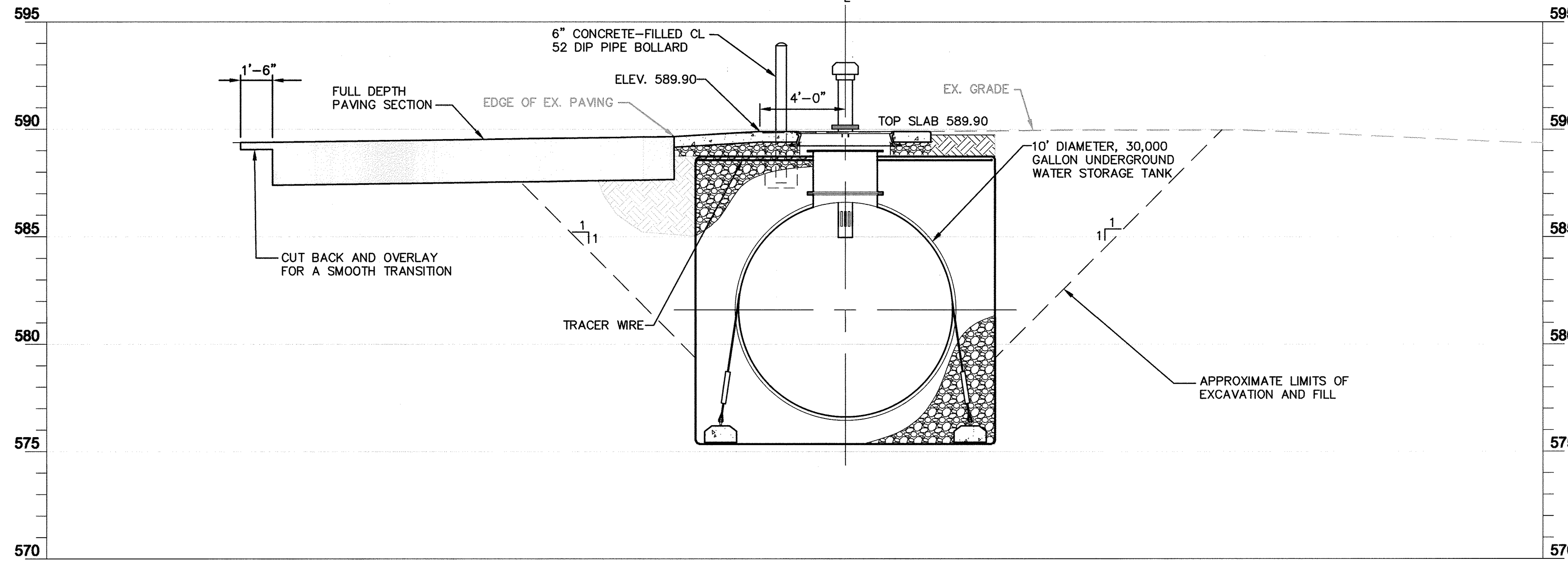

QUANTITIES				
ITEM	UNIT	ESTIMATE	AS-BUILT	MANUFACTURER
30,000 GALLON WATER STORAGE TANK, COMPLETE IN PLACE, WITH PIPING CONNECTIONS PER TABLE 1, SHEET 5 OF 6	EA.	1		
CONCRETE SLAB	SF	240		
ASPHALT PAVING	SF	1633		
BOLLARDS	EA	4		
REMOVE AND REINSTALL EX. FENCE	LF	57		
NAME OF UTILITY CONTRACTOR:				
		CHECKBOX		
		AS-BUILT DATE		
SURVEY AND DRAFTING DIVISION				

- NOTES:**
- FOR GENERAL TANK INSTALLATION, PIPING, SPECIFICATIONS, AND DETAILS REFER TO SHEETS 1-7 OF 7, INCLUSIVE.
  - ALL TREES AND PLANTINGS INTERFERING WITH EXCAVATION SHALL BE REMOVED REPLACED WITH VIABLE TREES OF SIMILAR SPECIES. TREES AND PLANTINGS THAT ARE NOT CALLED OUT ON THE PLANS AND NEED TO BE REMOVED FOR CONSTRUCTION SHALL BE IDENTIFIED TO THE HOWARD COUNTY INSPECTOR PRIOR TO REMOVAL.
  - THE CONTRACTOR SHALL TAKE ALL REASONABLE MEANS POSSIBLE TO PROTECT EXISTING TREES AND PLANTINGS WITHIN THE CONSTRUCTION AREA, AND SHALL REPLACE IN KIND THOSE DAMAGED OR REMOVED DURING CONSTRUCTION.
  - EROSION AND SEDIMENT CONTROL MEASURES SHALL BE INSTALLED IN ACCORDANCE WITH THE HOWARD COUNTY DESIGN MANUAL VOLUME IV, LATEST EDITION.
  - CONTRACTOR IS RESPONSIBLE FOR ACQUIRING ALL STAGING AREAS TO BE USED DURING CONSTRUCTION.
  - THERE SHALL BE NO STOCKPILING OF EXCAVATED MATERIAL ON THE WORK SITE.
  - ALL SURVEY STAKEOUT IS THE RESPONSIBILITY OF THE CONTRACTOR.
  - ALL TANK EXCAVATIONS MUST MEET OSHA REQUIREMENTS.
  - THE CONTRACTOR SHALL USE JERSEY BARRIERS TO PROTECT THE EXCAVATION. (SEE DETAIL MD 104.01-23B)(1:1 MAX TAPER)
  - USE MD 104.06-18 FOR WORKZONE SIGNING.
  - USE MD 104.01-71 FOR CRASH CUSHION DETAIL. USE 30mph AS DESIGN SPEED.
  - ROAD WORK 1500R. SIGN CAN BE ELIMINATED WHEN THE LENGTH OF ROAD IS LESS THAN 1500R.
  - PRIOR TO CONSTRUCTION, THE CONTRACTOR SHALL SCHEDULE A MEETING WITH HOWARD COUNTY TRAFFIC CONTROL MANAGER FOR THE APPROVAL OF MOT PLANS.

**SITE ANALYSIS:**

TOTAL AREA OF SITE	0.126	ACRES
AREA DISTURBED	0.126	ACRES
AREA TO BE ROOFED OR PAVED	0.042	ACRES
AREA TO BE VEGETATIVELY STABILIZED	0.084	ACRES
TOTAL CUT	693	CU. YDS.
TOTAL FILL	518	CU. YDS.
OFFSITE WASTE/BORROW AREA LOCATION	CONTRACTOR COORDINATE	

**UTILITY NOTE**

THE UNDERGROUND UTILITY LOCATIONS SHOWN HEREON HAVE BEEN LOCATED FROM A COMBINATION OF FIELD SURVEY INFORMATION, AERIAL SURVEY LOCATIONS, AND/OR EXISTING DRAWINGS. THE ENGINEER MAKES NO GUARANTEE THAT THE UNDERGROUND UTILITIES SHOWN COMPRISE ALL SUCH UTILITIES IN THE AREA, EITHER IN SERVICE OR ABANDONED. THE ENGINEER FURTHER DOES NOT WARRANT THAT THE UNDERGROUND UTILITIES SHOWN ARE IN THE EXACT LOCATION INDICATED, ALTHOUGH HE DOES CERTIFY THAT THEY ARE INDICATED ON THE AFOREMENTIONED INFORMATION OBTAINED BY THE ENGINEER.

THE CONTRACTOR IS RESPONSIBLE FOR CONTACTING "MISS UTILITY" 48 HOURS PRIOR TO CONSTRUCTION 1-800-257-7777.

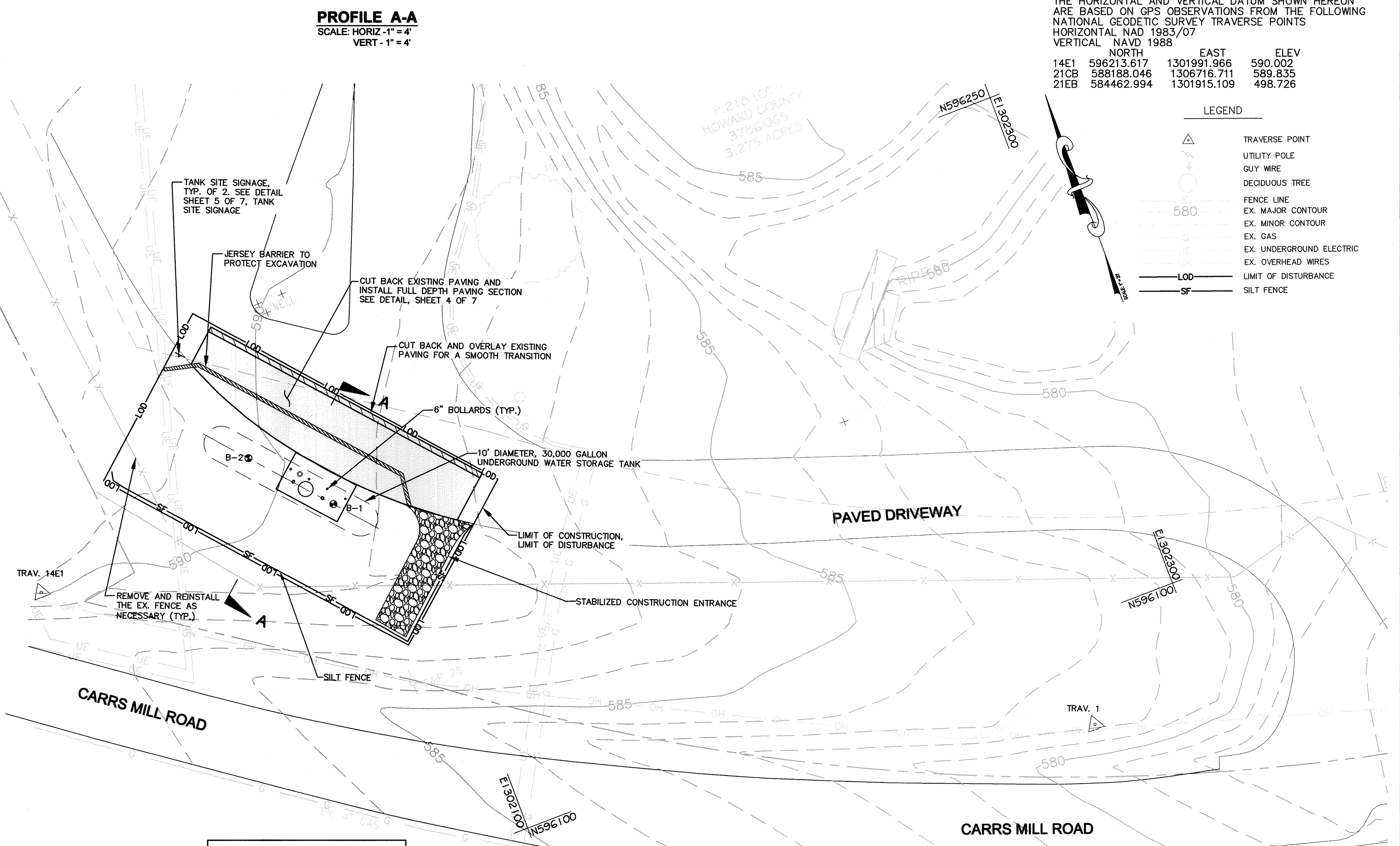

THE HORIZONTAL AND VERTICAL DATUM SHOWN HEREON ARE BASED ON GPS OBSERVATIONS FROM THE FOLLOWING NATIONAL GEODETIC SURVEY TRAVERSE POINTS

	NORTH	EAST	ELEV
14E1	596213.617	1301991.966	590.002
21CB	588188.046	1306716.711	589.835
21EB	584462.994	1301915.109	498.726

PROFESSIONAL CERTIFICATION: I hereby certify that these documents were prepared or approved by me, and that I am a duly licensed professional engineer under the laws of the State of Maryland, License No. 31363, Expiration Date 01/16/2018.

FOR LOCATION OF UTILITIES CALL  
1-800-257-7777  
OR LOG ON TO  
<http://www.missutility.net/tic/>  
48 HOURS IN ADVANCE OF ANY  
WORK IN THIS VICINITY

**SITE PLAN: RT-20 CARRS MILL RD**  
SCALE: 1" = 20'

**GRAPHIC SCALE**  
SCALE: 1" = 20'

JUL 10, 2017 - 11:40am User: kci\jason.m... M:\2017\13122677.3B\DWG\RT-20 Carrs Mill Rd.dwg

<p>DEPARTMENT OF PUBLIC WORKS HOWARD COUNTY, MARYLAND</p> <p><i>[Signature]</i> 7/18/17 DIRECTOR OF PUBLIC WORKS DATE</p> <p><i>[Signature]</i> 7/18/17 CHIEF, BUREAU OF ENGINEERING DATE</p> <p><i>[Signature]</i> 7/18/17 CHIEF, UTILITY DESIGN DIVISION DATE</p>		<p><b>KCI TECHNOLOGIES</b></p> <p>ENGINEERS PLANNERS SCIENTISTS CONSTRUCTION MANAGERS</p> <p>936 Ridgebrook Road Sparks, MD 21152 Phone: (410) 316-7800 Fax: (410) 316-7817 www.kci.com</p>	<p>STATE OF MARYLAND GUINIA WALKER PROFESSIONAL ENGINEER NO. 31363 7/10/2017</p>	<p>DES: KFJ DRN: KFJ CHK: GW DATE: JULY, 2017</p>	<p>CARRS MILL RD. AT WESTERN REGIONAL PARK</p>	<p>UNDERGROUND WATER STORAGE TANKS FOR FIRE SUPPRESSION</p> <p>CAPITAL PROJECT No. F-5972 CONTRACT No. 65-4959</p> <p>ELECTION DISTRICT NO. 4 HOWARD COUNTY, MARYLAND</p>	<p>SCALE AS SHOWN RT20</p>
---	--	---	--	---	--	---	------------------------------------



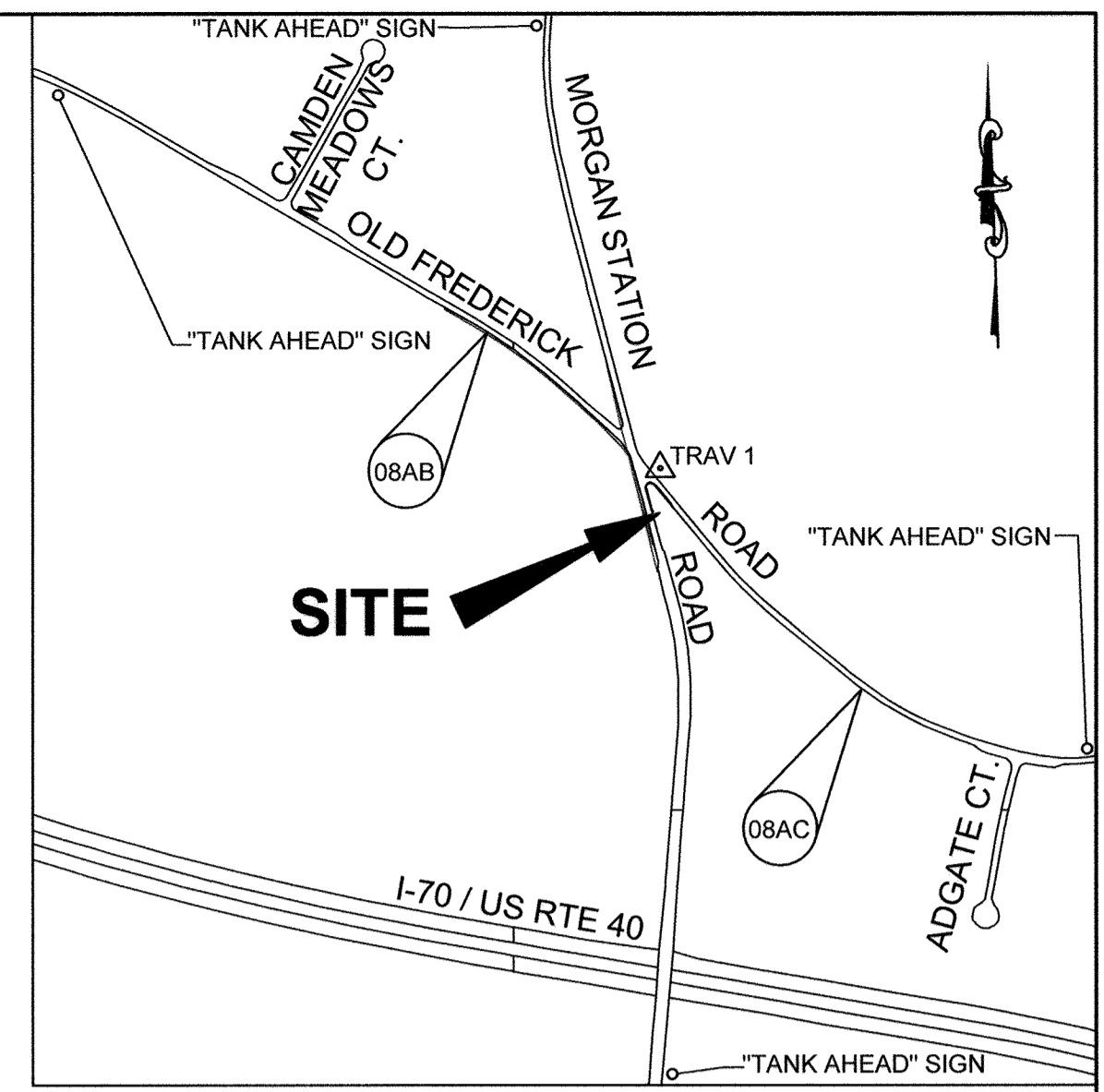
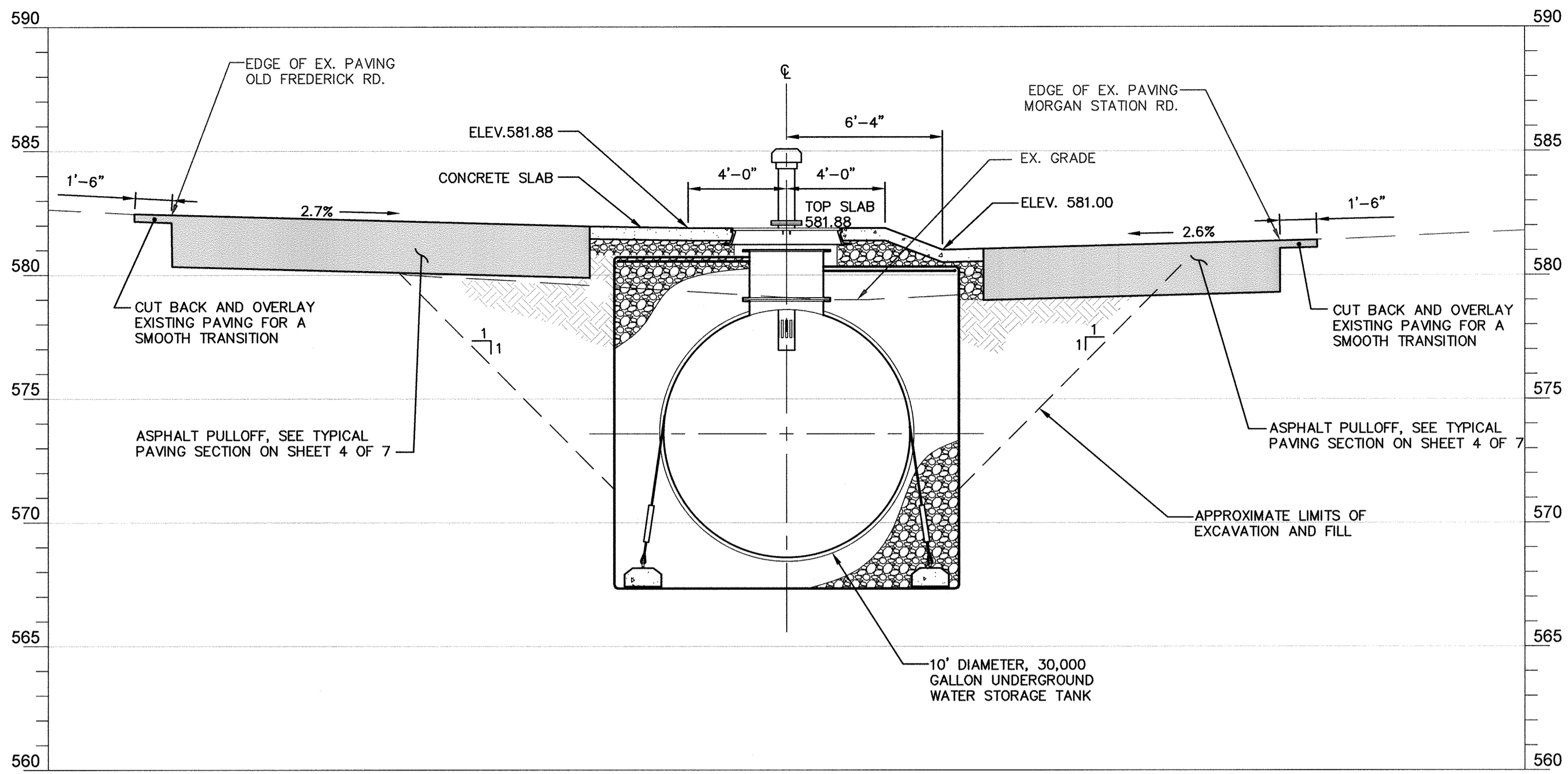
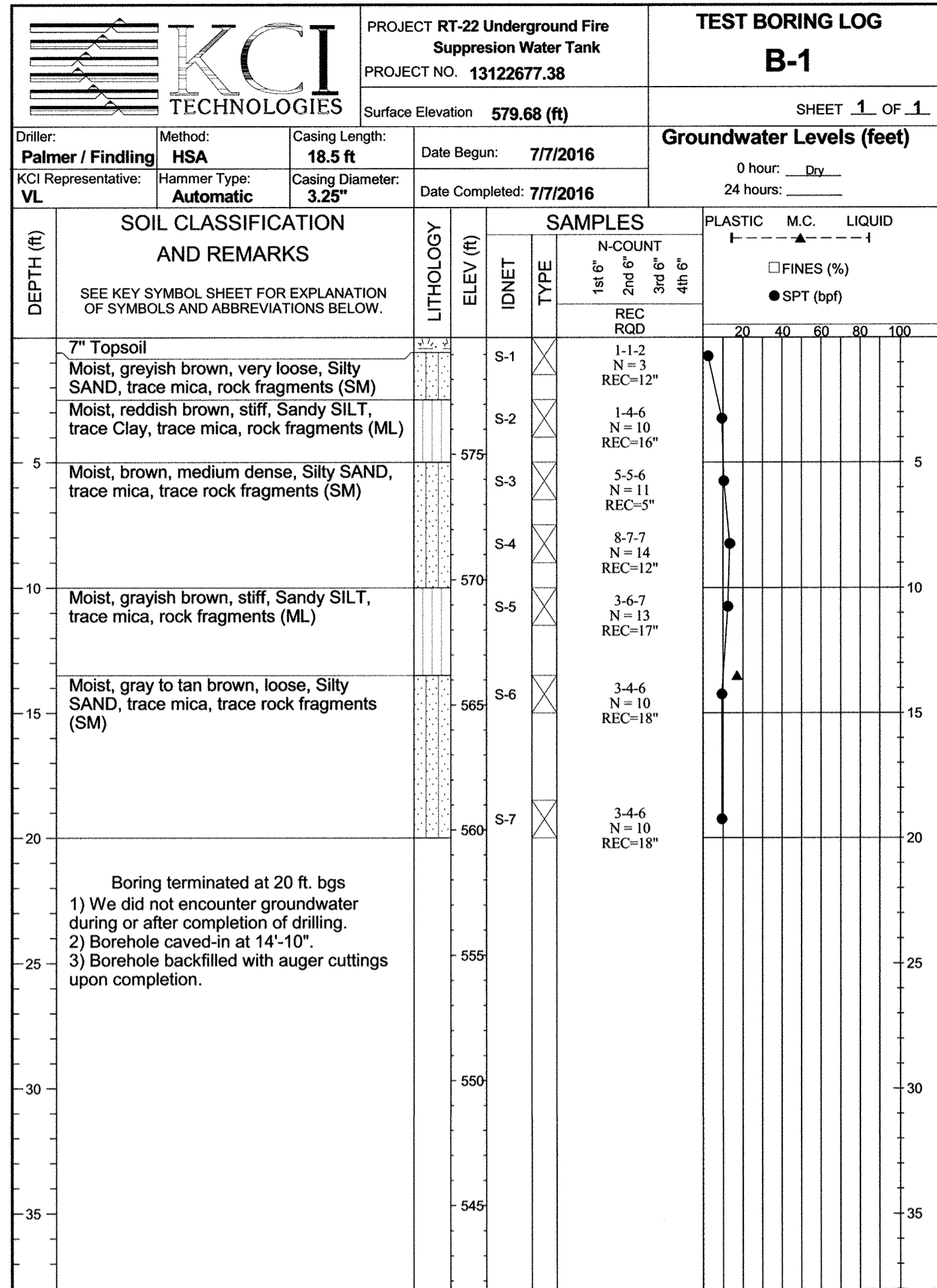

**UTILITY NOTE**

THE UNDERGROUND UTILITY LOCATIONS SHOWN HEREON HAVE BEEN LOCATED FROM A COMBINATION OF FIELD SURVEY INFORMATION, AERIAL SURVEY LOCATIONS, AND/OR EXISTING DRAWINGS. THE ENGINEER MAKES NO GUARANTEE THAT THE UNDERGROUND UTILITIES SHOWN COMPRISE ALL SUCH UTILITIES IN THE AREA, EITHER IN SERVICE OR ABANDONED. THE ENGINEER FURTHER DOES NOT WARRANT THAT THE UNDERGROUND UTILITIES SHOWN ARE IN THE EXACT LOCATION INDICATED, ALTHOUGH HE DOES CERTIFY THAT THEY ARE INDICATED ON THE AFOREMENTIONED INFORMATION OBTAINED BY THE ENGINEER.

THE CONTRACTOR IS RESPONSIBLE FOR CONTACTING "MISS UTILITY" 48 HOURS PRIOR TO CONSTRUCTION 1-800-257-7777.

**QUANTITIES**

ITEM	UNIT	ESTIMATE	AS-BUILT	MANUFACTURER
30,000 GALLON WATER STORAGE TANK, COMPLETE IN PLACE, WITH PIPING CONNECTIONS PER TABLE 1, SHEET 5 OF 7	EA.	1		
CONCRETE SLAB	SF	322		
ASPHALT PAVING	SF	2086		

NAME OF UTILITY CONTRACTOR:

CHECKBOX  
 AS-BUILT DATE  
 SURVEY AND DRAFTING DIVISION

**NOTES:**

- FOR GENERAL TANK INSTALLATION, PIPING, SPECIFICATIONS, AND DETAILS REFER TO SHEETS 1-7 OF 7, INCLUSIVE.
- ALL TREES AND PLANTINGS INTERFERING WITH EXCAVATION SHALL BE REMOVED REPLACED WITH VIABLE TREES OF SIMILAR SPECIES. TREES AND PLANTINGS THAT ARE NOT CALLED OUT ON THE PLANS AND NEED TO BE REMOVED FOR CONSTRUCTION SHALL BE IDENTIFIED TO THE HOWARD COUNTY INSPECTOR PRIOR TO REMOVAL.
- THE CONTRACTOR SHALL TAKE ALL REASONABLE MEANS POSSIBLE TO PROTECT EXISTING TREES AND PLANTINGS WITHIN THE CONSTRUCTION AREA, AND SHALL REPLACE IN KIND THOSE DAMAGED OR REMOVED DURING CONSTRUCTION.
- EROSION AND SEDIMENT CONTROL MEASURES SHALL BE INSTALLED IN ACCORDANCE WITH THE HOWARD COUNTY DESIGN MANUAL VOLUME IV, LATEST EDITION.
- CONTRACTOR IS RESPONSIBLE FOR ACQUIRING ALL STAGING AREAS TO BE USED DURING CONSTRUCTION.
- THERE SHALL BE NO STOCKPILING OF EXCAVATED MATERIAL ON THE WORK SITE.
- ALL SURVEY STAKEOUT IS THE RESPONSIBILITY OF THE CONTRACTOR.
- ALL TANK EXCAVATIONS MUST MEET OSHA REQUIREMENTS.
- THE CONTRACTOR SHALL USE JERSEY BARRIERS TO PROTECT THE EXCAVATION. (SEE DETAIL MD 104.01-23B)(1:1 MAX TAPER)
- USE MD 104.06-18 FOR WORKZONE SIGNING.
- USE MD 104.01-71 FOR CRASH CUSHION DETAIL. USE 30mph AS DESIGN SPEED.
- ROAD WORK 1500LF. SIGN CAN BE ELIMINATED WHEN THE LENGTH OF ROAD IS LESS THAN 1500LF.
- PRIOR TO CONSTRUCTION, THE CONTRACTOR SHALL SCHEDULE A MEETING WITH HOWARD COUNTY TRAFFIC CONTROL MANAGER FOR THE APPROVAL OF MOT PLANS.

**STAKEOUT TABLE**

DESCRIPTION	NORTHING	EASTING	ELEV
TRAV 1 (REBAR AND CAP)	610144.933	1298497.349	583.782
BORING B-1	610070.23	1298470.34	579.68
BORING B-2	610044.83	1298482.13	578.98
NW CORNER WEST ASPHALT PULLOFF	610081.16	1298449.62	581.37
NE CORNER WEST ASPHALT PULLOFF	610079.12	1298457.29	581.00
SW CORNER WEST ASPHALT PULLOFF	610005.95	1298469.44	581.45
SE CORNER WEST ASPHALT PULLOFF	610029.23	1298480.45	580.07
NW CORNER EAST ASPHALT PULLOFF	610085.93	1298471.98	581.66
NE CORNER EAST ASPHALT PULLOFF	610093.48	1298475.54	581.78
SW CORNER EAST ASPHALT PULLOFF	610036.04	1298495.13	581.41
SE CORNER EAST ASPHALT PULLOFF	610025.59	1298534.39	583.01
NW CORNER CONCRETE SLAB	610056.56	1298467.77	580.97
NE CORNER CONCRETE SLAB	610063.33	1298482.36	581.95
SW CORNER CONCRETE SLAB	610038.42	1298476.18	580.76
SE CORNER CONCRETE SLAB	610045.19	1298490.78	581.93
CENTER OF TANK MANWAY	610053.16	1298478.26	581.88

**SITE ANALYSIS:**

TOTAL AREA OF SITE	0.205	ACRES
AREA DISTURBED	0.205	ACRES
AREA TO BE ROOFED OR PAVED	0.061	ACRES
AREA TO BE VEGETATIVELY STABILIZED	0.144	ACRES
TOTAL CUT	508	CU. YDS.
TOTAL FILL	372	CU. YDS.
OFFSITE WASTE/BORROW AREA LOCATION	CONTRACTOR COORDINATE.	

FOR LOCATION OF UTILITIES CALL 1-800-257-7777 OR LOG ON TO <http://www.missutility.net/itc/>  
 48 HOURS IN ADVANCE OF ANY WORK IN THIS VICINITY

PROFESSIONAL CERTIFICATION: I hereby certify that these documents were prepared or approved by me, and that I am a duly licensed professional engineer under the laws of the State of Maryland, License No. 31363, Expiration Date 01/16/2018.

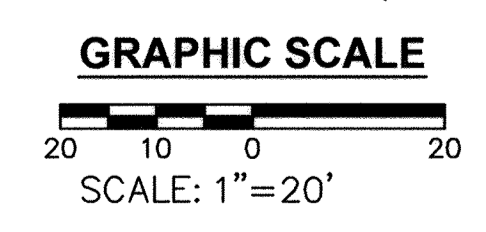
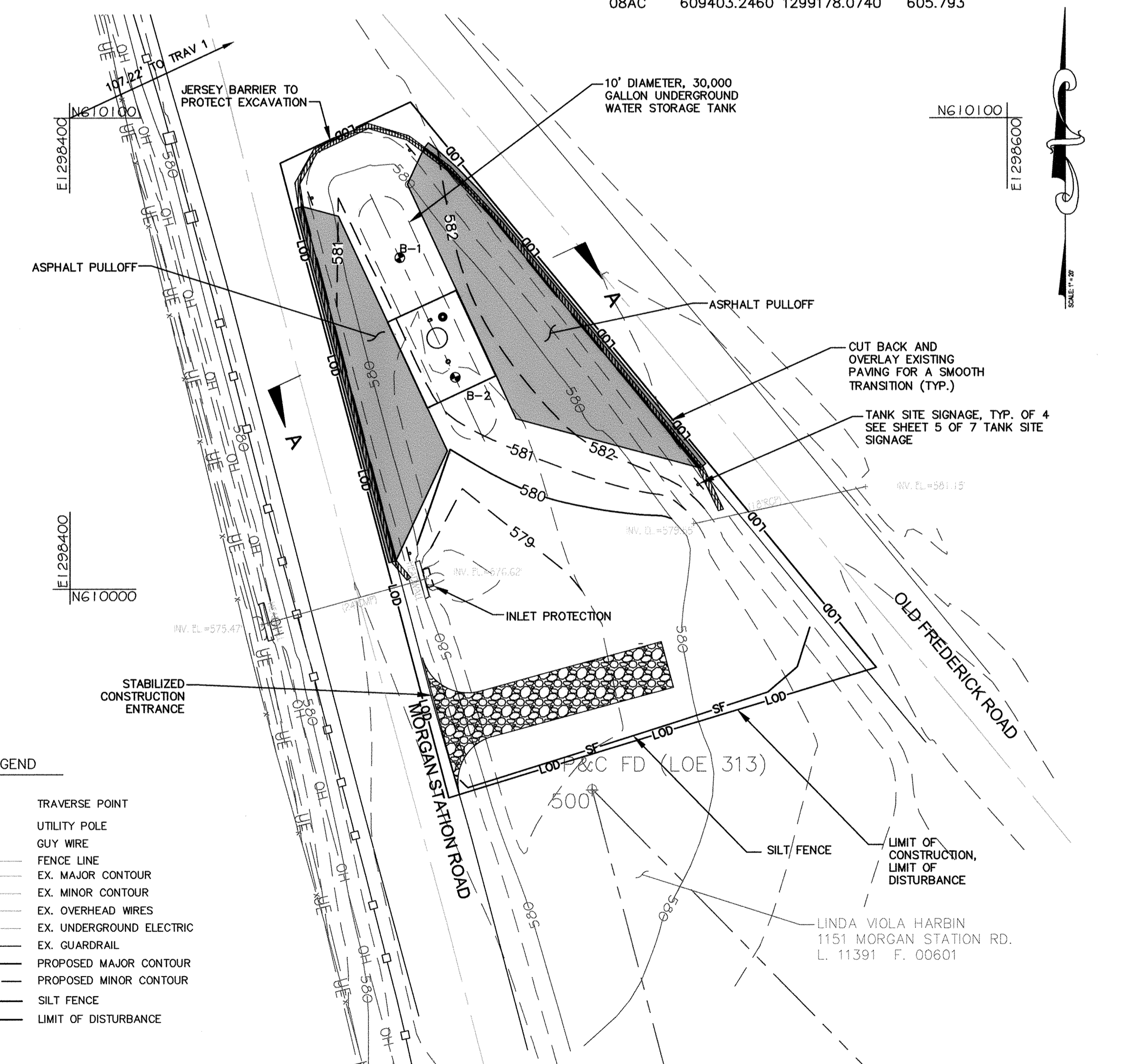

KCI TECHNOLOGIES PROJECT NO.: 13122677.38

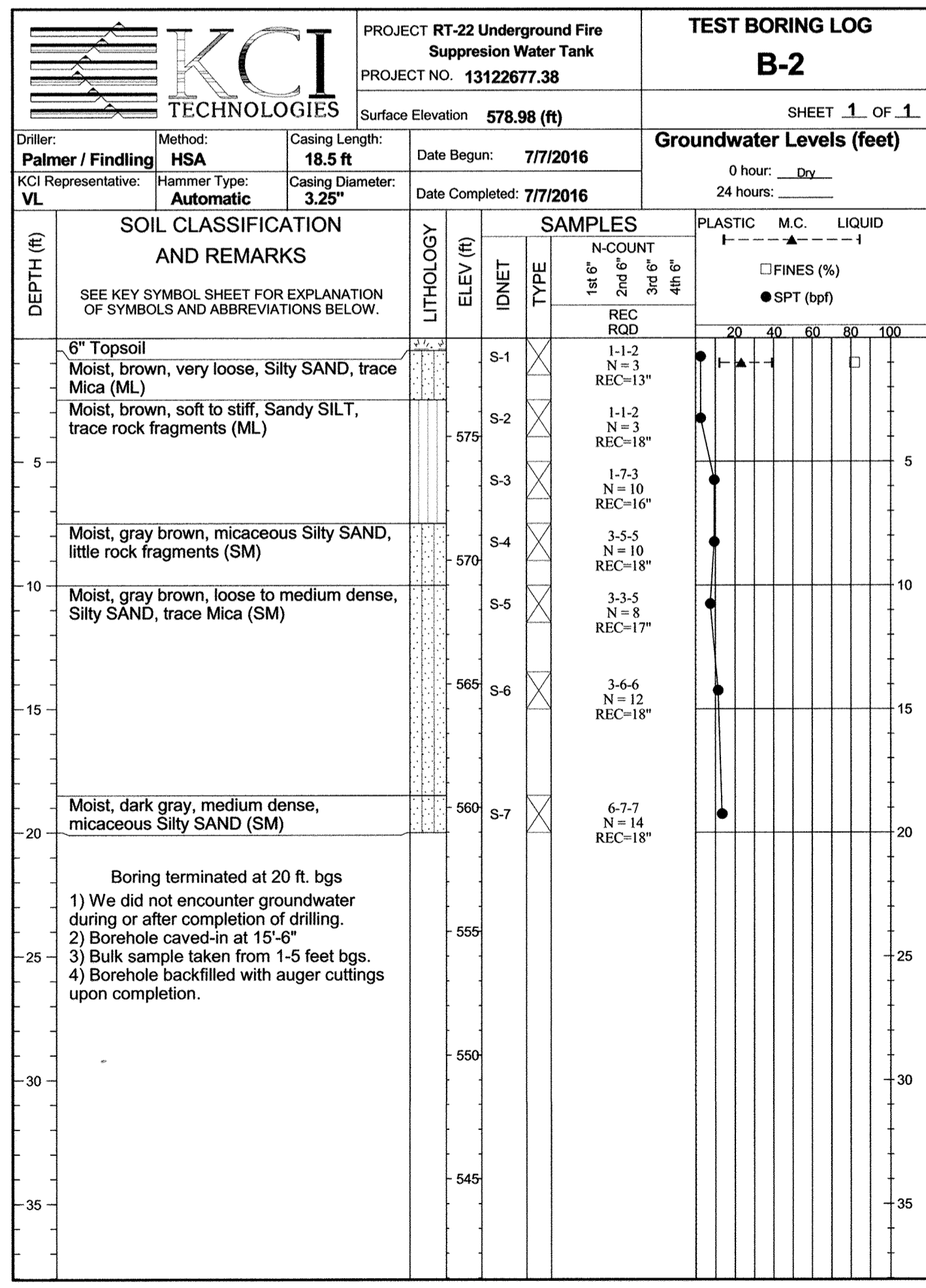

DEPARTMENT OF PUBLIC WORKS  
 HOWARD COUNTY, MARYLAND

Director of Public Works: *[Signature]* 6/14/17  
 Chief, Bureau of Engineering: *[Signature]* 6/12/17  
 Chief, Bureau of Utilities: *[Signature]* 6/14/17  
 Chief, Utility Design Division: *[Signature]* 6/12/17

ENGINEERS  
 PLANNERS  
 SCIENTISTS  
 CONSTRUCTION MANAGERS

**KCI TECHNOLOGIES**  
 936 Ridgeway Road  
 Sparks, MD 21152  
 Phone: (410) 316-7800  
 Fax: (410) 316-7817  
 www.kci.com

STATE OF MARYLAND  
 PROFESSIONAL ENGINEER  
 License No. 31363  
 6/01/2017

DES.	DRN.	CHK.	DATE:	BY	NO.	REVISION	DATE
KFJ	KFJ	GW	JUNE, 2017				

OLD FREDERICK RD.  
 AT  
 MORGAN STATION RD.

600' SCALE MAP NO. 8 BLOCK NO. 8

UNDERGROUND WATER STORAGE  
 TANKS FOR FIRE SUPPRESSION

CAPITAL PROJECT No. F-5972  
 CONTRACT No. 65-4959

ELECTION DISTRICT NO. 4 HOWARD COUNTY, MARYLAND

SCALE AS SHOWN  
 RT22

STAKEOUT TABLE			
DESCRIPTION	NORTHING	EASTING	ELEV
TRAV 41 (REBAR AND CAP)	611200.69	1285357.21	712.62
O2HD (HO. CO. CONTROL)	613910.96	1287573.30	736.34
BORING B-1	611232.09	1285315.09	709.72
BORING B-2	611207.24	1285302.18	709.16
NW CORNER ASPHALT PULLOFF	611289.49	1285296.72	712.11
NE CORNER ASPHALT PULLOFF	611275.71	1285363.73	713.19
SW CORNER ASPHALT PULLOFF	611279.01	1285290.87	711.14
SE CORNER ASPHALT PULLOFF	611229.48	1285339.84	711.60
NW CORNER CONCRETE SLAB	611287.66	1285324.60	711.70
NE CORNER CONCRETE SLAB	611277.90	1285342.06	711.70
SW CORNER CONCRETE SLAB	611277.18	1285318.74	711.70
SE CORNER CONCRETE SLAB	611267.43	1285336.20	711.70
CENTER OF TANK MANWAY	611280.51	1285329.19	711.70

QUANTITIES				
ITEM	UNIT	ESTIMATE	AS-BUILT	MANUFACTURER
REMOVE EXISTING FENCE	LF	65		
INSTALL NEW FENCE	LF	45		
30,000 GALLON WATER STORAGE TANK, COMPLETE IN PLACE, WITH PIPING CONNECTIONS PER TABLE 1, SHEET 5 OF 7	EA.	1		
ASPHALT PAVING	SF	965		
CONCRETE SLAB	SF	240		
NAME OF UTILITY CONTRACTOR:				
CHECKBOX				
AS-BUILT DATE				
SURVEY AND DRAFTING DIVISION				

- NOTES:**
- FOR GENERAL TANK INSTALLATION, PIPING, SPECIFICATIONS, AND DETAILS REFER TO SHEETS 1-7 OF 7, INCLUSIVE.
  - ALL TREES AND PLANTINGS INTERFERING WITH EXCAVATION SHALL BE REMOVED REPLACED WITH VIABLE TREES OF SIMILAR SPECIES. TREES AND PLANTINGS THAT ARE NOT CALLED OUT ON THE PLANS AND NEED TO BE REMOVED FOR CONSTRUCTION SHALL BE IDENTIFIED TO THE HOWARD COUNTY INSPECTOR PRIOR TO REMOVAL.
  - THE CONTRACTOR SHALL TAKE ALL REASONABLE MEANS POSSIBLE TO PROTECT EXISTING TREES AND PLANTINGS WITHIN THE CONSTRUCTION AREA, AND SHALL REPLACE IN KIND THOSE DAMAGED OR REMOVED DURING CONSTRUCTION.
  - EROSION AND SEDIMENT CONTROL MEASURES SHALL BE INSTALLED IN ACCORDANCE WITH THE HOWARD COUNTY DESIGN MANUAL VOLUME IV, LATEST EDITION.
  - CONTRACTOR IS RESPONSIBLE FOR ACQUIRING ALL STAGING AREAS TO BE USED DURING CONSTRUCTION.
  - THERE SHALL BE NO STOCKPILING OF EXCAVATED MATERIAL ON THE WORK SITE.
  - ALL SURVEY STAKEOUT IS THE RESPONSIBILITY OF THE CONTRACTOR.
  - ALL TANK EXCAVATIONS MUST MEET OSHA REQUIREMENTS.
  - THE CONTRACTOR SHALL USE JERSEY BARRIERS TO PROTECT THE EXCAVATION. (SEE DETAIL MD 104.01-23B)(1:1 MAX TAPER)
  - USE MD 104.06-18 FOR WORKZONE SIGNING.
  - USE MD 104.01-71 FOR CRASH CUSHION DETAIL. USE 30mph AS DESIGN SPEED.
  - ROAD WORK 1500R. SIGN CAN BE ELIMINATED WHEN THE LENGTH OF ROAD IS LESS THAN 1500R.
  - PRIOR TO CONSTRUCTION THE CONTRACTOR SHALL SCHEDULE A MEETING WITH HOWARD COUNTY TRAFFIC CONTROL MANAGER FOR THE APPROVAL OF MOT PLANS.

**UTILITY NOTE:**

THE UNDERGROUND UTILITY LOCATIONS SHOWN HEREON HAVE BEEN LOCATED FROM A COMBINATION OF FIELD SURVEY INFORMATION, AERIAL SURVEY LOCATIONS, AND/OR EXISTING DRAWINGS. THE ENGINEER MAKES NO GUARANTEE THAT THE UNDERGROUND UTILITIES SHOWN COMPRISE ALL SUCH UTILITIES IN THE AREA, EITHER IN SERVICE OR ABANDONED. THE ENGINEER FURTHER DOES NOT WARRANT THAT THE UNDERGROUND UTILITIES SHOWN ARE IN THE EXACT LOCATION INDICATED, ALTHOUGH HE DOES CERTIFY THAT THEY ARE INDICATED ON THE AFOREMENTIONED INFORMATION OBTAINED BY THE ENGINEER.

THE CONTRACTOR IS RESPONSIBLE FOR CONTACTING "MISS UTILITY" 48 HOURS PRIOR TO CONSTRUCTION 1-800-257-7777.

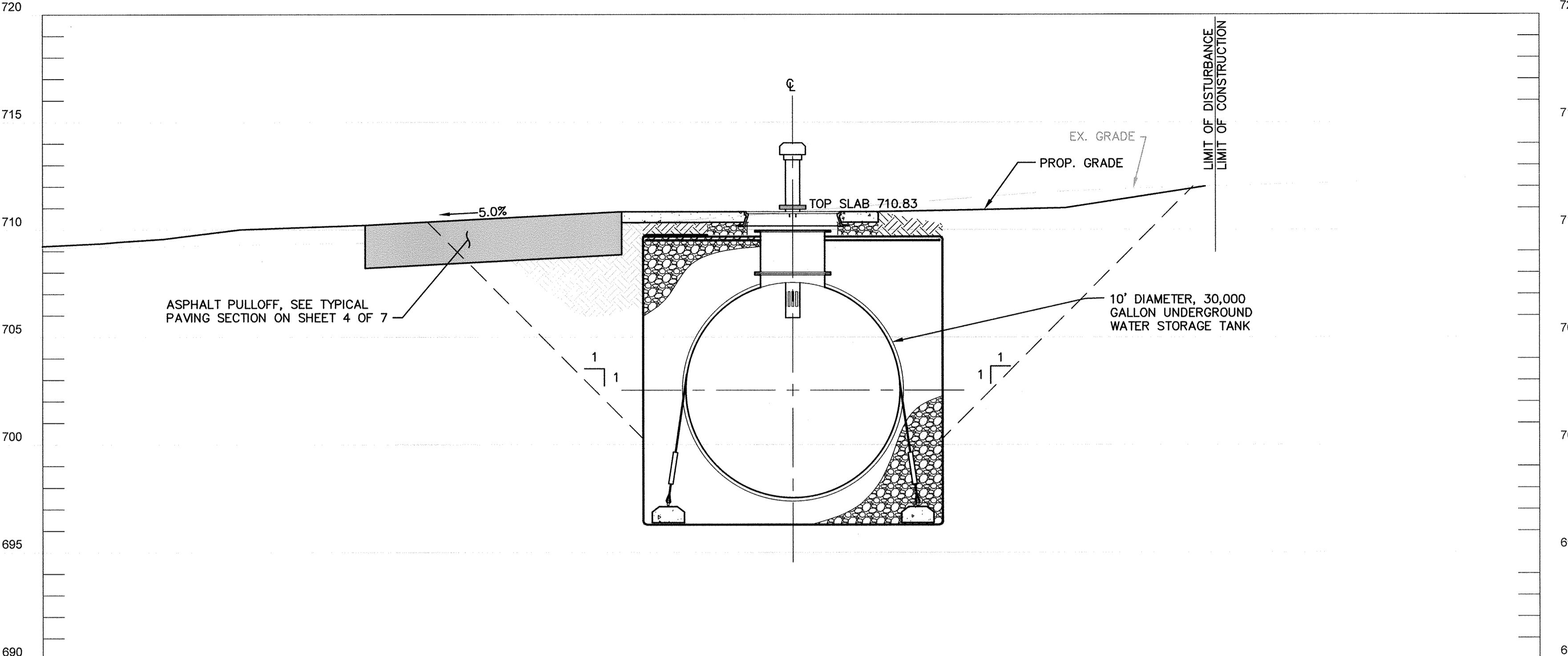

**PROFILE A-A**  
SCALE HORIZ - 1" = 4'  
VERT - 1" = 4'

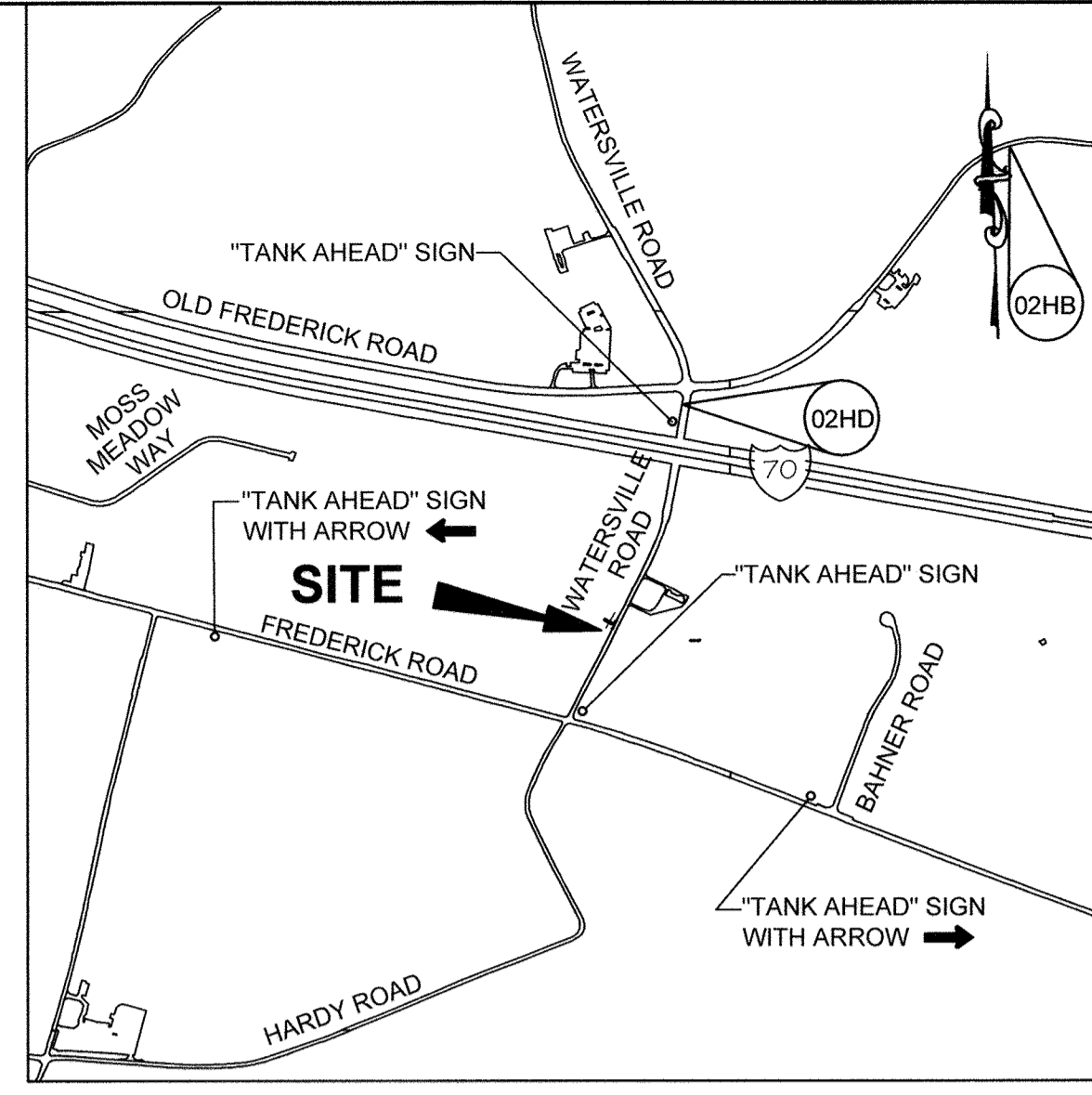

**SITE LOCATION MAP**  
SCALE: 1" = 1000'

**CONTROL NOTE:**

THE HORIZONTAL AND VERTICAL DATUM SHOWN HEREON ARE BASED ON GEODETIC HOWARD COUNTY SURVEY CONTROL POINTS HORIZONTAL NAD 1983/07, VERTICAL NAVD 1988

	NORTH	EAST	ELEV
O2HD	612479.80500	1285732.02800	746.12100
O2HB	613910.95700	1287573.30400	736.34000

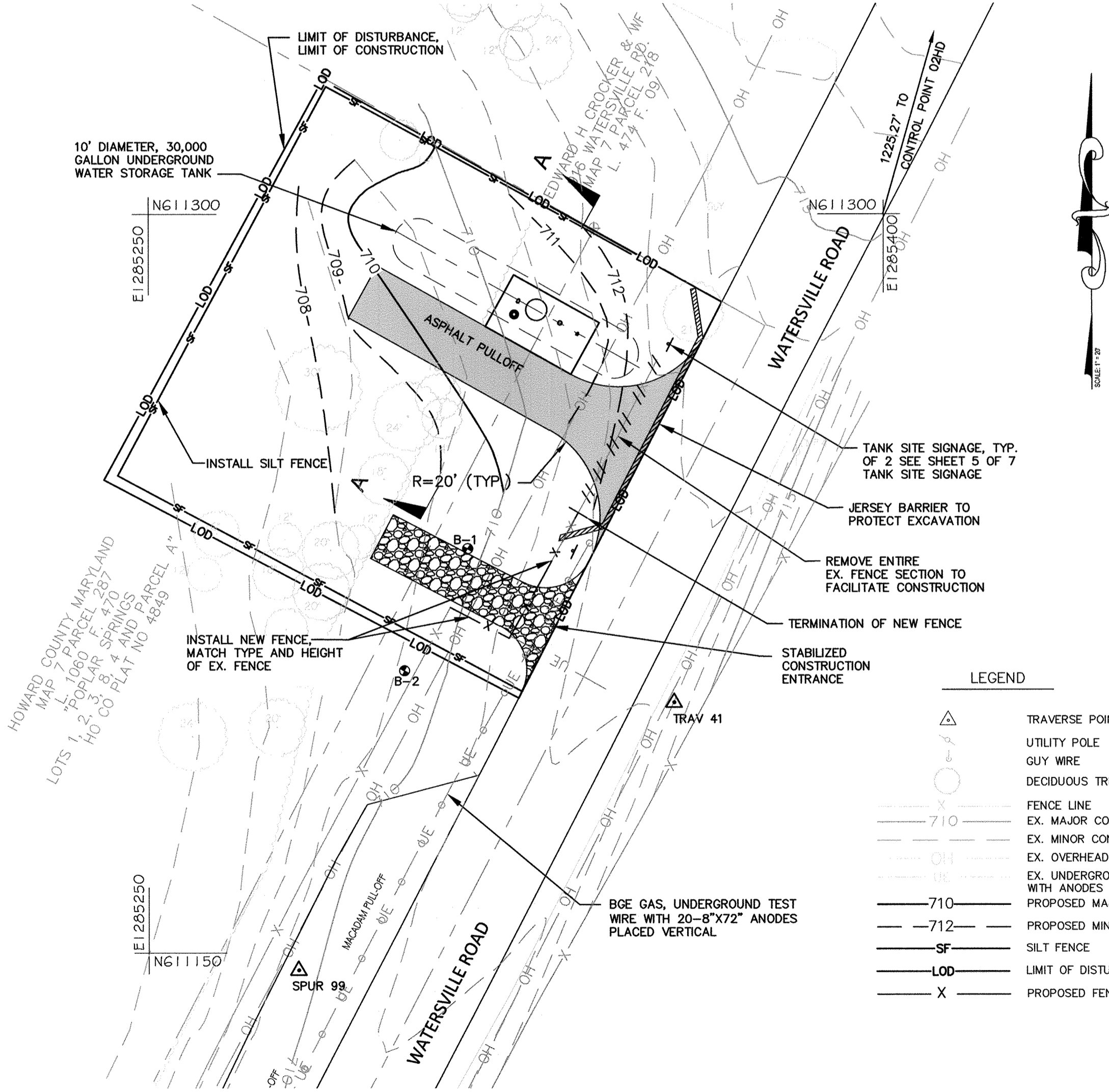

**SITE PLAN: RT-36 WATERSVILLE ROAD**  
SCALE: 1" = 20'

**SITE ANALYSIS:**

TOTAL AREA OF SITE	0.20	ACRES
AREA DISTURBED	0.20	ACRES
AREA TO BE ROOFED OR PAVED	0.03	ACRES
AREA TO BE VEGETATIVELY STABILIZED	0.17	ACRES
TOTAL CUT	692	CU. YDS.
TOTAL FILL	590	CU. YDS.
OFFSITE WASTE/BORROW AREA LOCATION	CONTRACTOR COORDINATE	

**LEGEND**

△	TRAVERSE POINT
○	UTILITY POLE
—	GUY WIRE
○	DECIDUOUS TREE
---	FENCE LINE
---	EX. MAJOR CONTOUR
---	EX. MINOR CONTOUR
---	EX. OVERHEAD WIRES
---	EX. UNDERGROUND TEST WIRE WITH ANODES
---	PROPOSED MAJOR CONTOUR
---	PROPOSED MINOR CONTOUR
---	SILT FENCE
---	LIMIT OF DISTURBANCE
X	PROPOSED FENCE

FOR LOCATION OF UTILITIES CALL  
1-800-257-7777  
OR LOG ON TO  
<http://www.missutility.net/itc/>  
48 HOURS IN ADVANCE OF ANY  
WORK IN THIS VICINITY

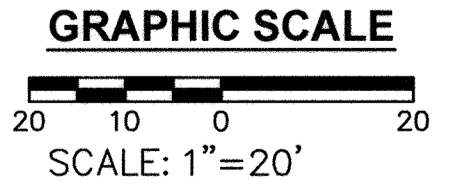

PROFESSIONAL CERTIFICATION. I hereby certify that these documents were prepared or approved by me, and that I am a duly licensed professional engineer under the laws of the State of Maryland, License No. 31383, Expiration Date 01/16/2020.

KCI TECHNOLOGIES PROJECT No. 13122677.38

KCI TECHNOLOGIES PROJECT No. 13122677.38

DEPARTMENT OF PUBLIC WORKS  
HOWARD COUNTY, MARYLAND

*Jerry L. Healy*  
DIRECTOR OF PUBLIC WORKS DATE 1-12-18

*James P. Butler III*  
CHIEF, BUREAU OF ENGINEERING DATE

*Robert J. Healy*  
CHIEF, UTILITY DESIGN DIVISION DATE P&D

**KCI TECHNOLOGIES**

ENGINEERS  
PLANNERS  
SCIENTISTS  
CONSTRUCTION MANAGERS

936 Ridgetop Road  
Sparks, MD 21152  
PHONE: (410) 316-7800  
FAX: (410) 316-7817  
www.kci.com

STATE OF MARYLAND  
GUYHU WANG  
Professional Engineer  
No. 31383  
01/05/2018

DES: KFJ					
DRN: KFJ					
CHK: GW					
DATE: JAN 2018	BY	NO.	REVISION	DATE	

**WATERSVILLE ROAD**

600' SCALE MAP NO. 7 BLOCK NO. 3

**UNDERGROUND WATER STORAGE TANKS FOR FIRE SUPPRESSION**

CAPITAL PROJECT No. F-5972  
CONTRACT No. 65-4959

ELECTION DISTRICT NO. 4 HOWARD COUNTY, MARYLAND

SCALE AS SHOWN  
**RT36**

KCI TECHNOLOGIES PROJECT No.: 13122677\_38

STAKEOUT TABLE			
DESCRIPTION	NORTHING	EASTING	ELEV
TRAV 41 (REBAR AND CAP)	550232.069	1330624.258	494.78
TRAV 98 (REBAR AND CAP)	550233.840	1330729.236	495.54
BORING B-1	550206.47	1330688.67	500.00
BORING B-2	550188.28	1330709.97	500.34
NW CORNER ASPHALT PULLOFF	550238.34	1330682.29	495.00
NE CORNER ASPHALT PULLOFF	550187.04	1330742.36	498.42
SW CORNER ASPHALT PULLOFF	550221.42	1330683.62	497.62
SE CORNER ASPHALT PULLOFF	550185.70	1330725.45	497.84
NW CORNER CONCRETE SLAB	550205.20	1330702.48	497.65
NE CORNER CONCRETE SLAB	550192.21	1330717.68	497.65
SW CORNER CONCRETE SLAB	550196.08	1330694.68	497.65
SE CORNER CONCRETE SLAB	550183.09	1330709.89	497.65
CENTER OF TANK MANWAY	550194.25	1330702.98	497.65

QUANTITIES				
ITEM	UNIT	ESTIMATE	AS-BUILT	MANUFACTURER
30,000 GALLON WATER STORAGE TANK, COMPLETE IN PLACE, WITH PIPING CONNECTIONS PER TABLE 1, SHEET 5 OF 6	EA.	1		
CONCRETE SLAB	SF	240		
ASPHALT PAVING	SF	804		
NAME OF UTILITY CONTRACTOR:				
		CHECKBOX		
		AS-BUILT DATE		
SURVEY AND DRAFTING DIVISION				

**NOTES:**

- FOR GENERAL TANK INSTALLATION, PIPING, SPECIFICATIONS, AND DETAILS REFER TO SHEETS 1-7 OF 7, INCLUSIVE.
- ALL TREES AND PLANTINGS INTERFERING WITH EXCAVATION SHALL BE REMOVED REPLACED WITH VIABLE TREES OF SIMILAR SPECIES. TREES AND PLANTINGS THAT ARE NOT CALLED OUT ON THE PLANS AND NEED TO BE REMOVED FOR CONSTRUCTION SHALL BE IDENTIFIED TO THE HOWARD COUNTY INSPECTOR PRIOR TO REMOVAL.
- THE CONTRACTOR SHALL TAKE ALL REASONABLE MEANS POSSIBLE TO PROTECT EXISTING TREES AND PLANTINGS WITHIN THE CONSTRUCTION AREA, AND SHALL REPLACE IN KIND THOSE DAMAGED OR REMOVED DURING CONSTRUCTION.
- EROSION AND SEDIMENT CONTROL MEASURES SHALL BE INSTALLED IN ACCORDANCE WITH THE HOWARD COUNTY DESIGN MANUAL VOLUME IV, LATEST EDITION.
- CONTRACTOR IS RESPONSIBLE FOR ACQUIRING ALL STAGING AREAS TO BE USED DURING CONSTRUCTION.
- THERE SHALL BE NO STOCKPILING OF EXCAVATED MATERIAL ON THE WORK SITE.
- ALL SURVEY STAKEOUT IS THE RESPONSIBILITY OF THE CONTRACTOR.
- ALL TANK EXCAVATIONS MUST MEET OSHA REQUIREMENTS.
- THE CONTRACTOR SHALL USE JERSEY BARRIERS TO PROTECT THE EXCAVATION. (SEE DETAIL MD 104.01-23B)(11:1 MAX TAPER)
- USE MD 104.06-18 FOR WORKZONE SIGNING.
- USE MD 104.01-71 FOR CRASH CUSHION DETAIL. USE 30mph AS DESIGN SPEED.
- ROAD WORK 1500R. SIGN CAN BE ELIMINATED WHEN THE LENGTH OF ROAD IS LESS THAN 1500R.
- PRIOR TO CONSTRUCTION, THE CONTRACTOR SHALL SCHEDULE A MEETING WITH HOWARD COUNTY TRAFFIC CONTROL MANAGER FOR THE APPROVAL OF MOT PLANS.

**UTILITY NOTE:**

THE UNDERGROUND UTILITY LOCATIONS SHOWN HEREON HAVE BEEN LOCATED FROM A COMBINATION OF FIELD SURVEY INFORMATION, AERIAL SURVEY LOCATIONS, AND/OR EXISTING DRAWINGS. THE ENGINEER MAKES NO GUARANTEE THAT THE UNDERGROUND UTILITIES SHOWN COMPRISE ALL SUCH UTILITIES IN THE AREA, EITHER IN SERVICE OR ABANDONED. THE ENGINEER FURTHER DOES NOT WARRANT THAT THE UNDERGROUND UTILITIES SHOWN ARE IN THE EXACT LOCATION INDICATED, ALTHOUGH HE DOES CERTIFY THAT THEY ARE INDICATED ON THE AFOREMENTIONED INFORMATION OBTAINED BY THE ENGINEER.

THE CONTRACTOR IS RESPONSIBLE FOR CONTACTING "MISS UTILITY" 48 HOURS PRIOR TO CONSTRUCTION 1-800-257-7777.

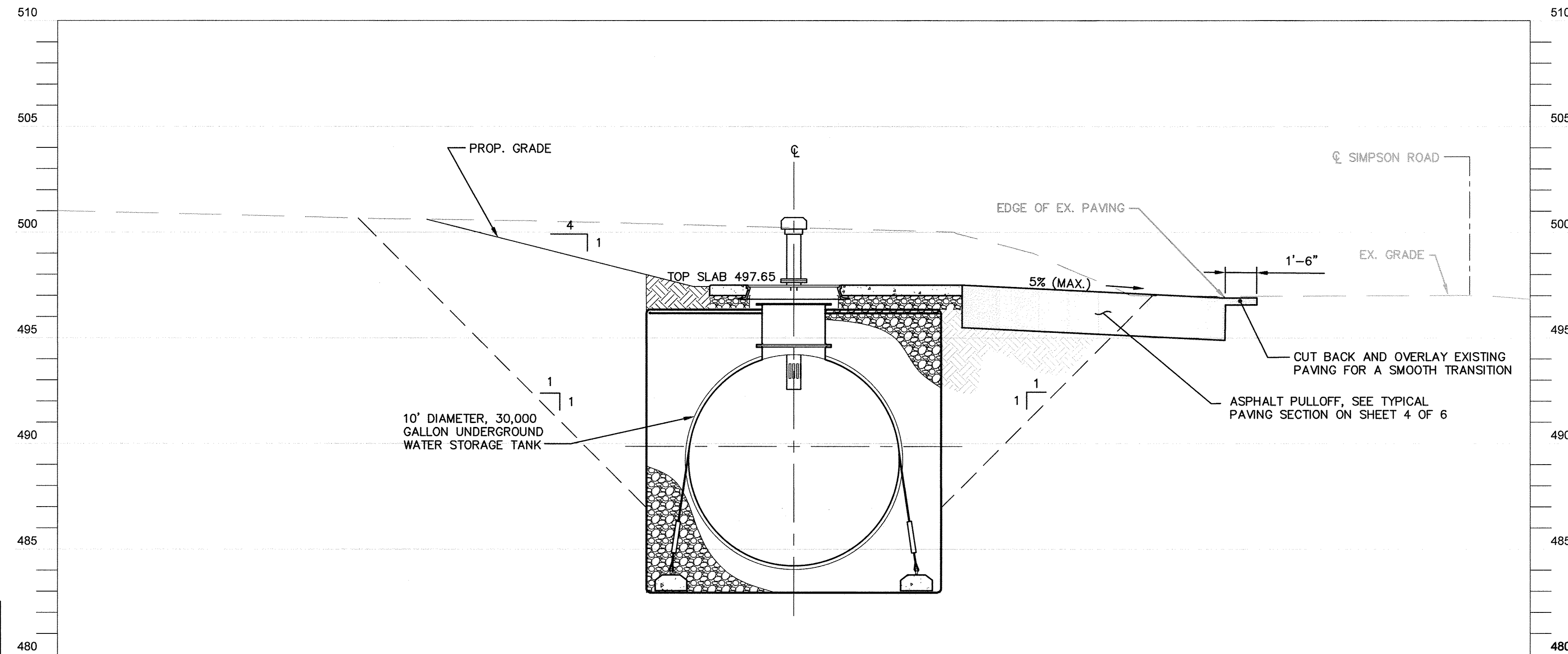

**PROFILE A-A**  
SCALE: HORIZ - 1" = 4'  
VERT - 1" = 4'

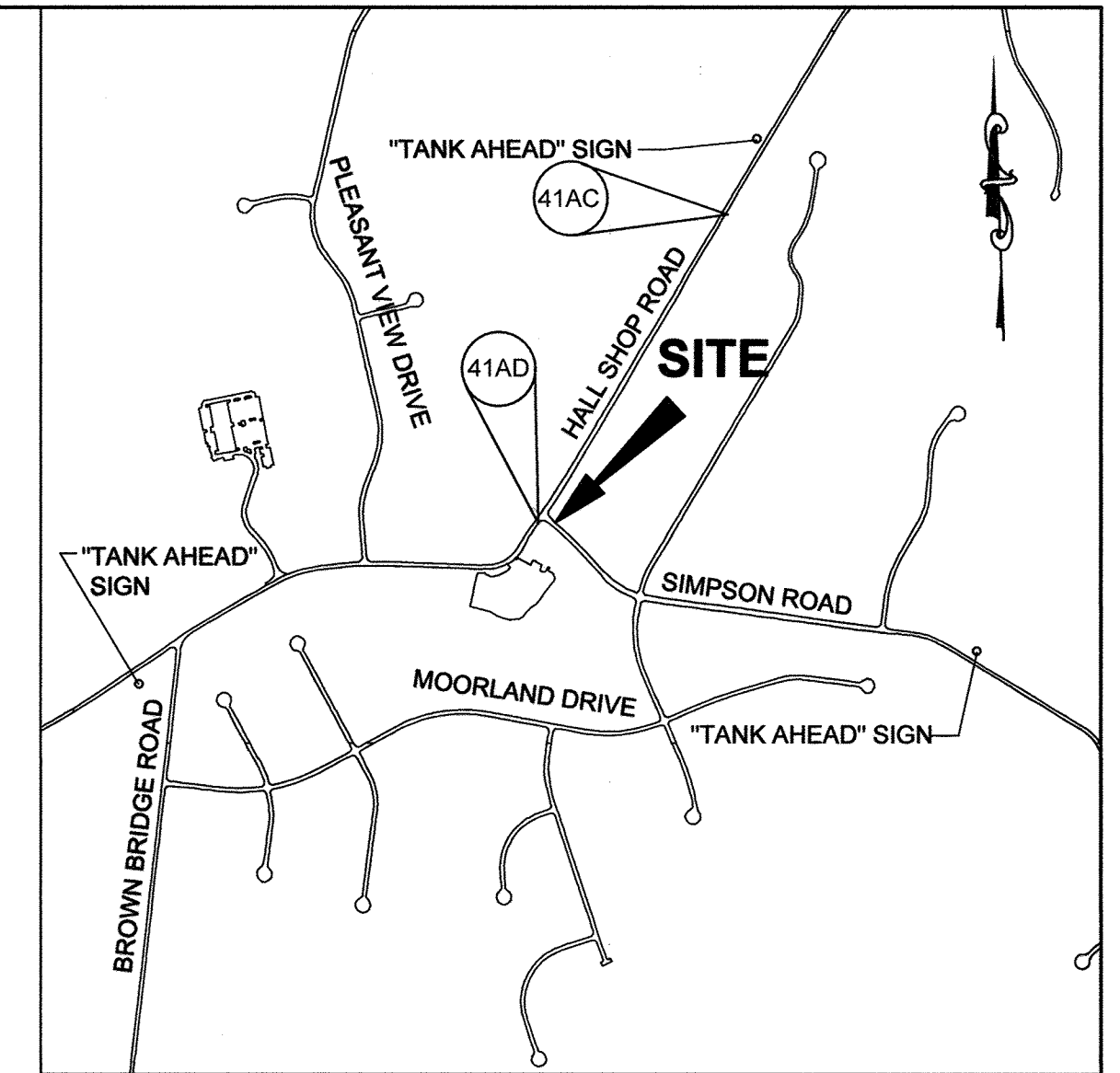

**SITE LOCATION MAP**  
SCALE: 1" = 1000'

**CONTROL NOTE:**

THE HORIZONTAL AND VERTICAL DATUM SHOWN HEREON ARE BASED ON THE FOLLOWING HOWARD COUNTY GEODETIC SURVEY CONTROL TRAVERSE

HORIZONTAL NAD 1983/91  
VERTICAL NAVD 1988

	NORTH	EAST	ELEV
41AD	550232.06900	1330624.25800	494.779
41AC	551969.53900	1331695.40100	488.323

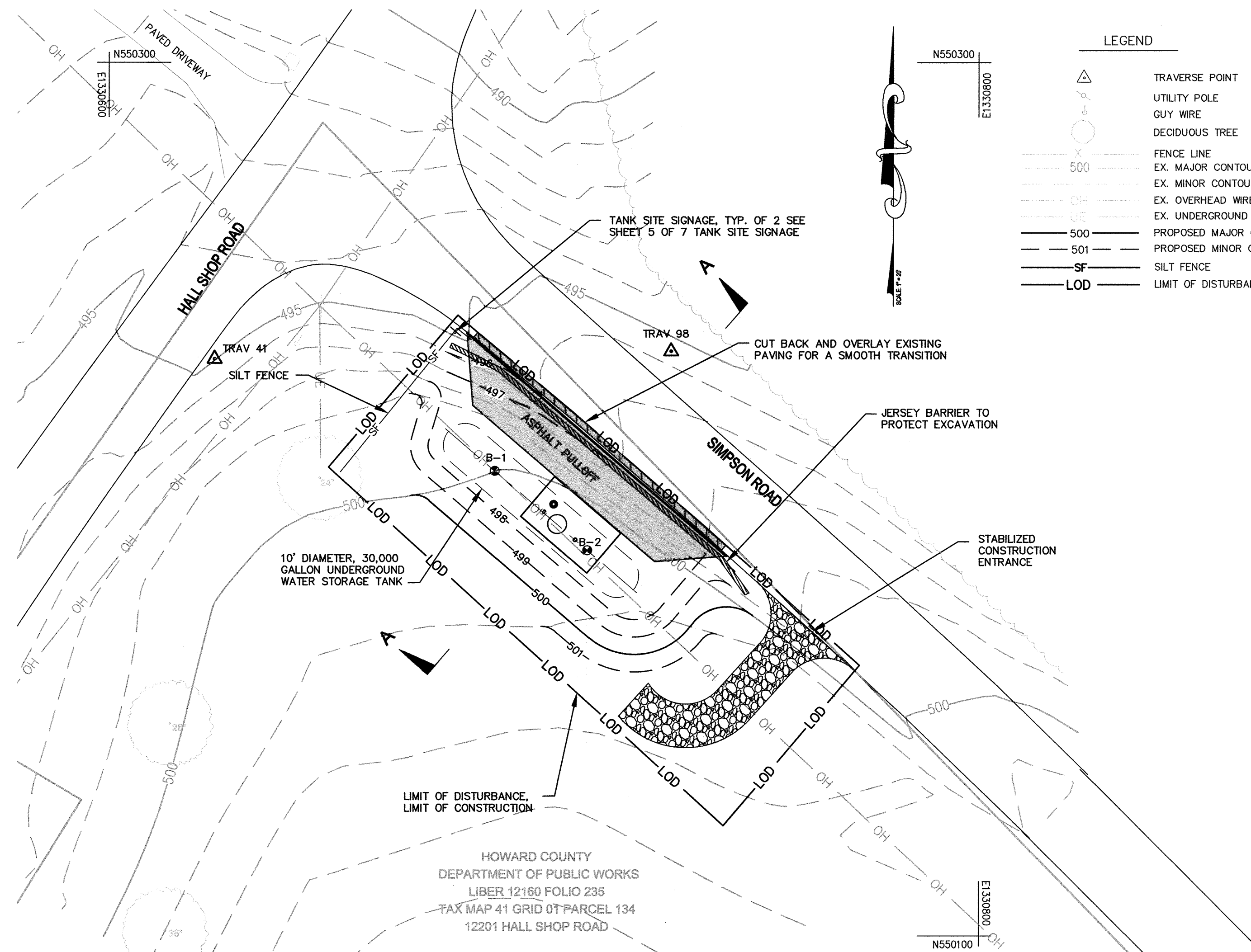

**SITE PLAN: RT-42 SIMPSON ROAD**  
SCALE: 1" = 20'

FOR LOCATION OF UTILITIES CALL  
1-800-257-7777  
OR LOG ON TO  
<http://www.missutility.net/itc/>  
48 HOURS IN ADVANCE OF ANY  
WORK IN THIS VICINITY

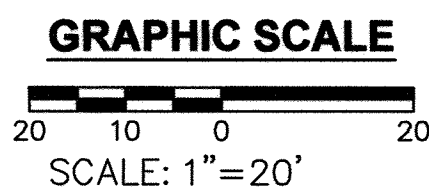

PROFESSIONAL CERTIFICATION: I hereby certify that these documents were prepared or approved by me, and that I am a duly licensed professional engineer under the laws of the State of Maryland, License No. 31363, Expiration Date 01/16/2018.

**DEPARTMENT OF PUBLIC WORKS**  
HOWARD COUNTY, MARYLAND

*[Signature]* DATE 7/10/17  
DIRECTOR OF PUBLIC WORKS

*[Signature]* DATE 7/10/17  
CHIEF, BUREAU OF UTILITIES

*[Signature]* DATE 7/10/17  
CHIEF, BUREAU OF ENGINEERING

*[Signature]* DATE 7/10/17  
CHIEF, UTILITY DESIGN DIVISION

**KCI TECHNOLOGIES**

ENGINEERS  
PLANNERS  
SCIENTISTS  
CONSTRUCTION MANAGERS

936 Ridgebrook Road  
Sparks, MD 21152  
Phone: (410) 316-7800  
Fax: (410) 316-7817  
www.kci.com

**STATE OF MARYLAND**  
GUY WALKER  
PROFESSIONAL ENGINEER  
NO. 31363  
7/10/2017

DES: KFJ					
DRN: KFJ					
CHK: GW					
DATE: JULY, 2017	BY	NO.	REVISION	DATE	600' SCALE MAP NO. 41 BLOCK NO. 1

**SIMPSON ROAD AT HALL SHOP ROAD**

**UNDERGROUND WATER STORAGE TANKS FOR FIRE SUPPRESSION**

CAPITAL PROJECT No. F-5972  
CONTRACT No. 65-4959

ELECTION DISTRICT NO. 5 HOWARD COUNTY, MARYLAND

SCALE AS SHOWN  
RT42

JUL 10 2017 11:42 AM User: kci\jwalk Date: 7/10/17 M:\2017\13122677\_38\DWG\RT-42\RT-42\_HALL SHOP ROAD - SIMPSON ROAD.DWG

KCI TECHNOLOGIES PROJECT NO.: 1312267.38

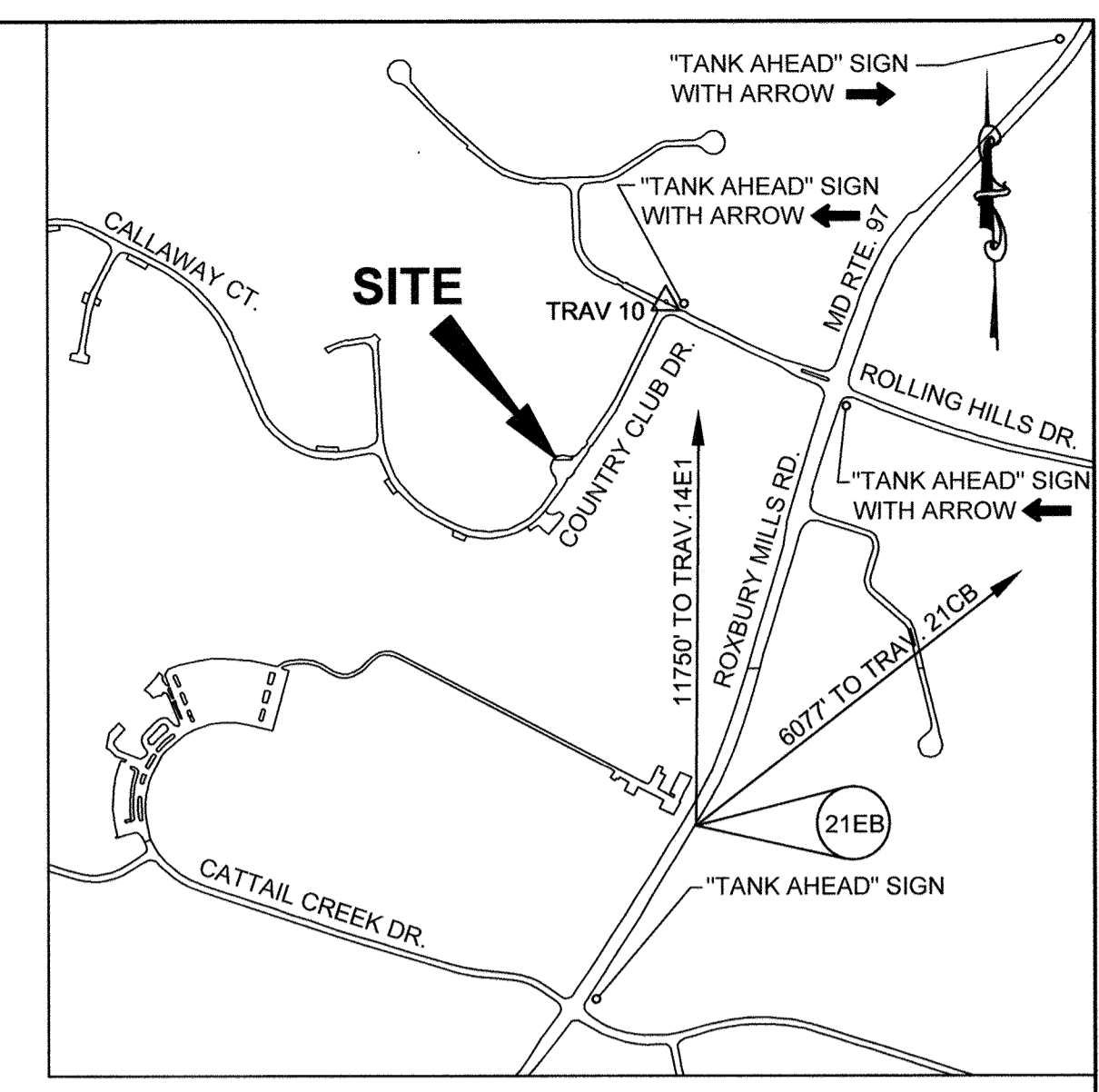
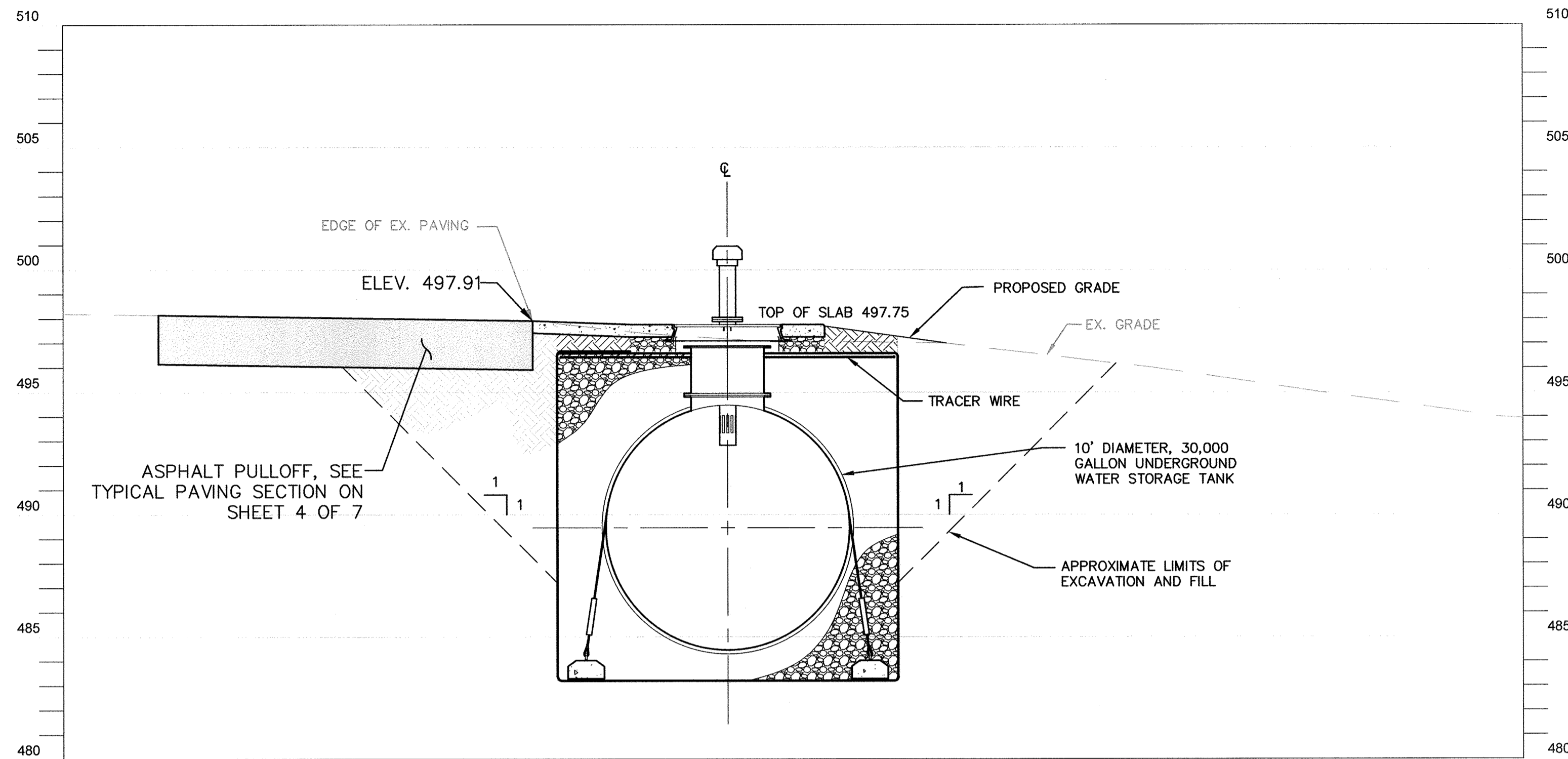

**SITE LOCATION MAP**  
SCALE: 1" = 600'

**CONTROL NOTE:**  
THE HORIZONTAL AND VERTICAL DATUM SHOWN HEREON ARE BASED ON GPS GEODETIC HOWARD COUNTY CONTROL POINTS

HORIZONTAL NAD 1983/07  
VERTICAL NAVD 1988

	NORTH	EAST	ELEV
14E1	596213.617	1301991.966	590.002
21CB	588188.046	1306716.711	589.635
21EB	584462.994	1301915.109	498.726

**SITE ANALYSIS:**

TOTAL AREA OF SITE	0.17	ACRES
AREA DISTURBED	0.17	ACRES
AREA TO BE ROOFED OR PAVED	0.02	ACRES
AREA TO BE VEGETATIVELY STABILIZED	0.15	ACRES
TOTAL CUT	420	CU. YDS.
TOTAL FILL	324	CU. YDS.
OFFSITE WASTE/BORROW AREA LOCATION	CONTRACTOR COORDINATE	

- NOTES:**
- FOR GENERAL TANK INSTALLATION, PIPING, SPECIFICATIONS, AND DETAILS REFER TO SHEETS 1-7 OF 7, INCLUSIVE.
  - ALL TREES AND PLANTINGS INTERFERING WITH EXCAVATION SHALL BE REMOVED REPLACED WITH VIABLE TREES OF SIMILAR SPECIES. TREES AND PLANTINGS THAT ARE NOT CALLED OUT ON THE PLANS AND NEED TO BE REMOVED FOR CONSTRUCTION SHALL BE IDENTIFIED TO THE HOWARD COUNTY INSPECTOR PRIOR TO REMOVAL.
  - THE CONTRACTOR SHALL TAKE ALL REASONABLE MEANS POSSIBLE TO PROTECT EXISTING TREES AND PLANTINGS WITHIN THE CONSTRUCTION AREA, AND SHALL REPLACE IN KIND THOSE DAMAGED OR REMOVED DURING CONSTRUCTION.
  - EROSION AND SEDIMENT CONTROL MEASURES SHALL BE INSTALLED IN ACCORDANCE WITH THE HOWARD COUNTY DESIGN MANUAL VOLUME IV, LATEST EDITION.
  - CONTRACTOR IS RESPONSIBLE FOR ACQUIRING ALL STAGING AREAS TO BE USED DURING CONSTRUCTION.
  - THERE SHALL BE NO STOCKPILING OF EXCAVATED MATERIAL ON THE WORK SITE.
  - ALL SURVEY STAKEOUT IS THE RESPONSIBILITY OF THE CONTRACTOR.
  - ALL TANK EXCAVATIONS MUST MEET OSHA REQUIREMENTS.
  - THE CONTRACTOR SHALL USE JERSEY BARRIERS TO PROTECT THE EXCAVATION. (SEE DETAIL MD 104-01-23B)(11:1 MAX TAPER)
  - USE MD 104.06-18 FOR WORKZONE SIGNING.
  - USE MD 104.01-71 FOR CRASH CUSHION DETAIL. USE 30mph AS DESIGN SPEED.
  - ROAD WORK 1500R. SIGN CAN BE ELIMINATED WHEN THE LENGTH OF ROAD IS LESS THAN 1500R.
  - PRIOR TO CONSTRUCTION THE CONTRACTOR SHALL SCHEDULE A MEETING WITH HOWARD COUNTY TRAFFIC CONTROL MANAGER FOR THE APPROVAL OF MOT PLANS.

**UTILITY NOTE:**  
THE UNDERGROUND UTILITY LOCATIONS SHOWN HEREON HAVE BEEN LOCATED FROM A COMBINATION OF FIELD SURVEY INFORMATION, AERIAL SURVEY LOCATIONS, AND/OR EXISTING DRAWINGS. THE ENGINEER MAKES NO GUARANTEE THAT THE UNDERGROUND UTILITIES SHOWN COMPRISE ALL SUCH UTILITIES IN THE AREA, EITHER IN SERVICE OR ABANDONED. THE ENGINEER FURTHER DOES NOT WARRANT THAT THE UNDERGROUND UTILITIES SHOWN ARE IN THE EXACT LOCATION INDICATED, ALTHOUGH HE DOES CERTIFY THAT THEY ARE INDICATED ON THE AFOREMENTIONED INFORMATION OBTAINED BY THE ENGINEER.

THE CONTRACTOR IS RESPONSIBLE FOR CONTACTING "MISS UTILITY" 48 HOURS PRIOR TO CONSTRUCTION 1-800-257-7777.

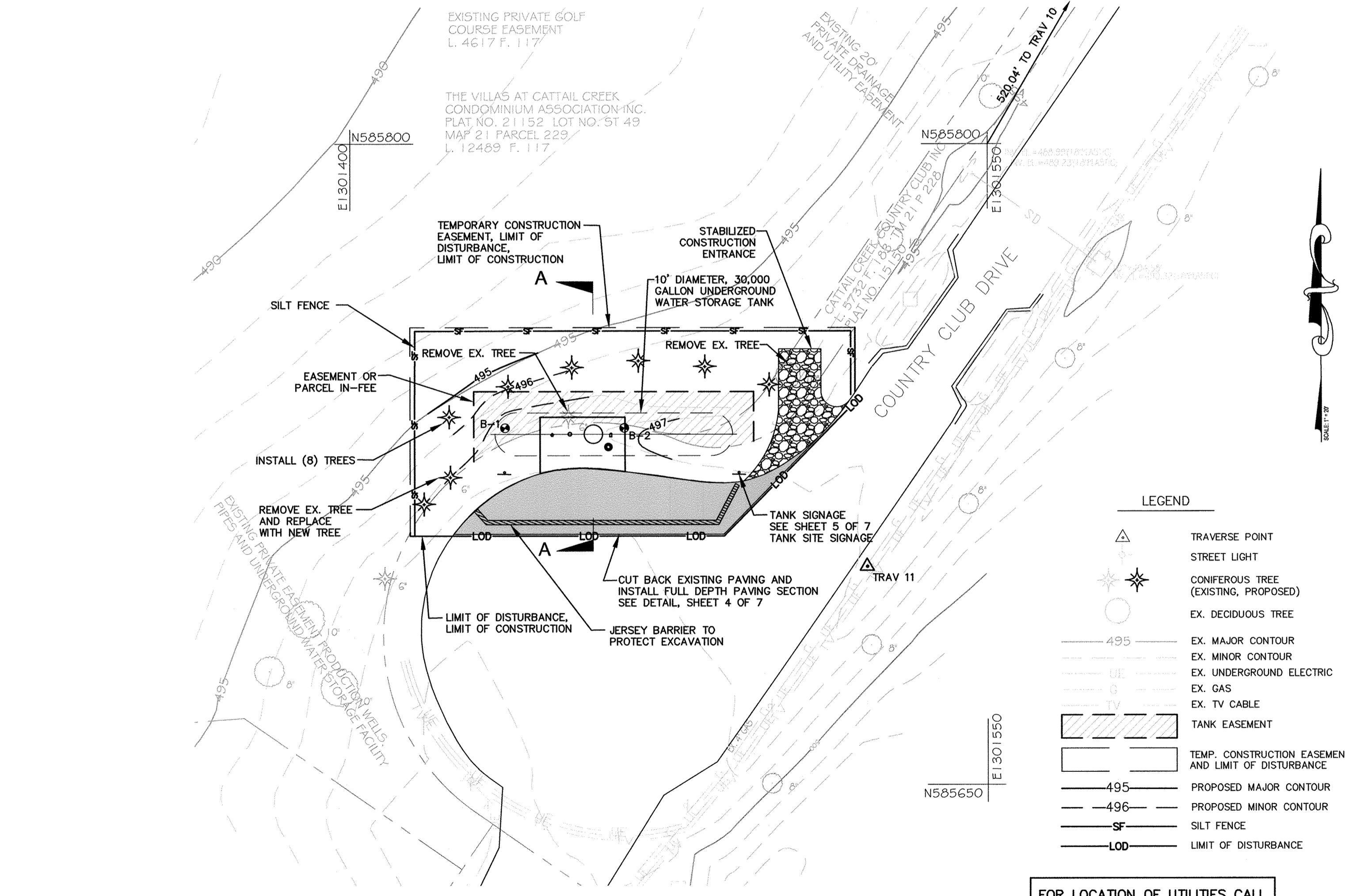

**SITE PLAN: RT-48 COUNTRY CLUB DRIVE**  
SCALE: 1" = 20'

FOR LOCATION OF UTILITIES CALL  
1-800-257-7777  
OR LOG ON TO  
<http://www.missutility.net/itc/>  
48 HOURS IN ADVANCE OF ANY  
WORK IN THIS VICINITY

**STAKEOUT TABLE**

DESCRIPTION	NORTHING	EASTING	ELEV
TRAV 10 (REBAR AND CAP)	586249.07	1301812.25	512.85
TRAV 11 (REBAR AND CAP)	585701.05	1301521.61	496.86
BORING B-1	585733.46	1301436.43	496.77
BORING B-2	585733.46	1301464.43	496.98
WEST CORNER ASPHALT PULLOFF	585708.60	1301424.36	498.49
NE CORNER ASPHALT PULLOFF	585731.61	1301510.48	497.38
SE CORNER ASPHALT PULLOFF	585708.60	1301487.89	497.51
NW CORNER CONCRETE SLAB	585735.99	1301444.67	497.50
NE CORNER CONCRETE SLAB	585735.99	1301464.67	497.50
SW CORNER CONCRETE SLAB	585722.80	1301444.67	497.50
SE CORNER CONCRETE SLAB	585723.28	1301464.67	497.50
NW CORNER TANK EASEMENT	585741.99	1301429.07	494.31
NE CORNER TANK EASEMENT	585741.99	1301494.90	494.38
SW CORNER TANK EASEMENT	585725.63	1301429.07	497.15
SE CORNER TANK EASEMENT	585730.43	1301494.90	496.99
CENTER OF TANK MANWAY	585731.99	1301457.17	497.50

**QUANTITIES**

ITEM	UNIT	ESTIMATE	AS-BUILT	MANUFACTURER
30,000 GALLON WATER STORAGE TANK, COMPLETE IN PLACE, WITH PIPING CONNECTIONS PER TABLE 1, SHEET 5 OF 7	EA.	1		
CONCRETE SLAB	SF	245		
ASPHALT PAVING	SF	882		
REMOVE EX. CONIFEROUS TREE	EA.	1		
REMOVE EX. DECIDUOUS TREE	EA.	1		
INSTALL CONIFEROUS TREE	EA.	8		

NAME OF UTILITY CONTRACTOR:

CHECKBOX	AS-BUILT DATE
<input type="checkbox"/>	

SURVEY AND DRAFTING DIVISION

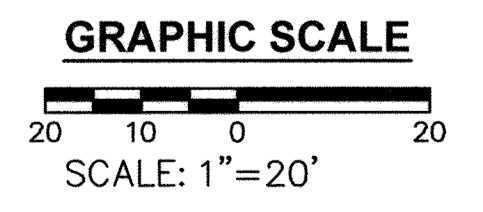

PROFESSIONAL CERTIFICATION. I hereby certify that these documents were prepared or approved by me, and that I am a duly licensed professional engineer under the laws of the State of Maryland, License No. 31383, Expiration Date 01/16/2020.

DEPARTMENT OF PUBLIC WORKS  
HOWARD COUNTY, MARYLAND

*John D. White*  
DIRECTOR, PUBLIC WORKS DATE 1-12-18

*Thomas E. Sullivan*  
CHIEF, BUREAU OF ENGINEERING DATE 1/11/18

*Chris...*  
CHIEF, BUREAU OF UTILITIES DATE

*...*  
CHIEF, UTILITY DESIGN DIVISION DATE

**KCI TECHNOLOGIES**

ENGINEERS  
PLANNERS  
SCIENTISTS  
CONSTRUCTION MANAGERS

936 Ridgebrook Road  
Sparks, MD 21152  
PHONE: (410) 316-7800  
FAX: (410) 316-7817  
[www.kci.com](http://www.kci.com)

STATE OF MARYLAND  
GUYHUA WANG  
PROFESSIONAL ENGINEER  
NO. 31383  
01/05/2018

DESIGNER	DATE	BY	NO.	REVISION	DATE
KFJ					
KFJ					
GW					
	JAN. 2018				

**COUNTRY CLUB DRIVE**

600' SCALE MAP NO. 21 BLOCK NO. 3

**UNDERGROUND WATER STORAGE TANKS FOR FIRE SUPPRESSION**

CAPITAL PROJECT No. F-5972  
CONTRACT No. 65-4959

ELECTION DISTRICT NO. 4 HOWARD COUNTY, MARYLAND

SCALE AS SHOWN  
**RT48**

Jan 05, 2018, 8:09am User: hrcs/edw/2018  
M:\0216\131207\26\Drawings\RT-48\RT-48 - COUNTRY CLUB DRIVE.dwg

STAKEOUT TABLE			
DESCRIPTION	NORTHING	EASTING	ELEV
TRAV 2 (REBAR AND CAP)	599141.58	1273420.02	631.73
TRAV 3 (REBAR AND CAP)	598036.98	1273226.53	673.62
BORING B-1	599290.03	1273499.11	623.77
BORING B-2	599284.26	1273471.71	623.55
NW CORNER ASPHALT PULLOFF	599273.56	1273460.17	625.03
NE CORNER ASPHALT PULLOFF	599284.89	1273513.99	624.58
SW CORNER ASPHALT PULLOFF	599259.28	1273450.91	625.90
SE CORNER ASPHALT PULLOFF	599275.48	1273528.23	624.53
NW CORNER CONCRETE SLAB	599287.49	1273467.64	625.14
NE CORNER CONCRETE SLAB	599291.61	1273487.21	625.14
SW CORNER CONCRETE SLAB	599275.75	1273470.11	625.14
SE CORNER CONCRETE SLAB	599279.87	1273489.68	625.14
CENTER OF TANK MANWAY	599286.15	1273480.70	625.14

QUANTITIES				
ITEM	UNIT	ESTIMATE	AS-BUILT	MANUFACTURER
30,000 GALLON WATER STORAGE TANK, COMPLETE IN PLACE, WITH PIPING CONNECTIONS PER TABLE 1, SHEET 5 OF 6	EA.	1		
CONCRETE SLAB	SF	240		
ASPHALT PAVING	SF	880		
NAME OF UTILITY CONTRACTOR:				
		CHECKBOX		
		AS-BUILT DATE		
SURVEY AND DRAFTING DIVISION				

**NOTES:**

- FOR GENERAL TANK INSTALLATION, PIPING, SPECIFICATIONS, AND DETAILS REFER TO SHEETS 1-7 OF 7, INCLUSIVE.
- ALL TREES AND PLANTINGS INTERFERING WITH EXCAVATION SHALL BE REMOVED REPLACED WITH VIABLE TREES OF SIMILAR SPECIES. TREES AND PLANTINGS THAT ARE NOT CALLED OUT ON THE PLANS AND NEED TO BE REMOVED FOR CONSTRUCTION SHALL BE IDENTIFIED TO THE HOWARD COUNTY INSPECTOR PRIOR TO REMOVAL.
- THE CONTRACTOR SHALL TAKE ALL REASONABLE MEANS POSSIBLE TO PROTECT EXISTING TREES AND PLANTINGS WITHIN THE CONSTRUCTION AREA, AND SHALL REPLACE IN KIND THOSE DAMAGED OR REMOVED DURING CONSTRUCTION.
- EROSION AND SEDIMENT CONTROL MEASURES SHALL BE INSTALLED IN ACCORDANCE WITH THE HOWARD COUNTY DESIGN MANUAL VOLUME IV, LATEST EDITION.
- CONTRACTOR IS RESPONSIBLE FOR ACQUIRING ALL STAGING AREAS TO BE USED DURING CONSTRUCTION.
- THERE SHALL BE NO STOCKPILING OF EXCAVATED MATERIAL ON THE WORK SITE.
- ALL SURVEY STAKEOUT IS THE RESPONSIBILITY OF THE CONTRACTOR.
- ALL TANK EXCAVATIONS MUST MEET OSHA REQUIREMENTS.
- THE CONTRACTOR SHALL USE JERSEY BARRIERS TO PROTECT THE EXCAVATION. (SEE DETAIL MD 104.01-23B)(11:1 MAX TAPER)
- USE MD 104.06-18 FOR WORKZONE SIGNING.
- USE MD 104.01-71 FOR CRASH CUSHION DETAIL. USE 30mph AS DESIGN SPEED.
- ROAD WORK 1500R. SIGN CAN BE ELIMINATED WHEN THE LENGTH OF ROAD IS LESS THAN 1500R.
- PRIOR TO CONSTRUCTION, THE CONTRACTOR SHALL SCHEDULE A MEETING WITH HOWARD COUNTY TRAFFIC CONTROL MANAGER FOR THE APPROVAL OF MOT PLANS.

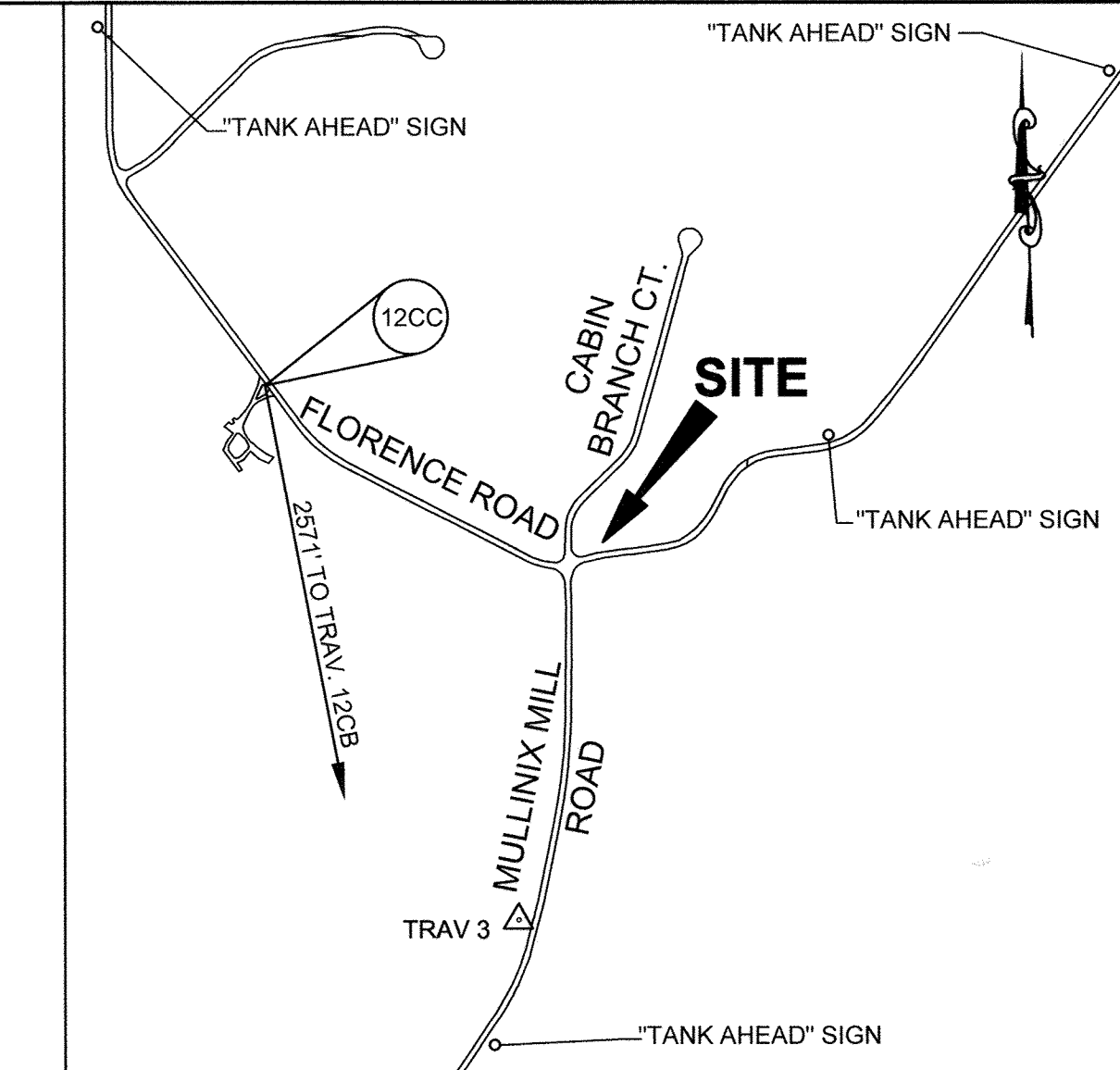
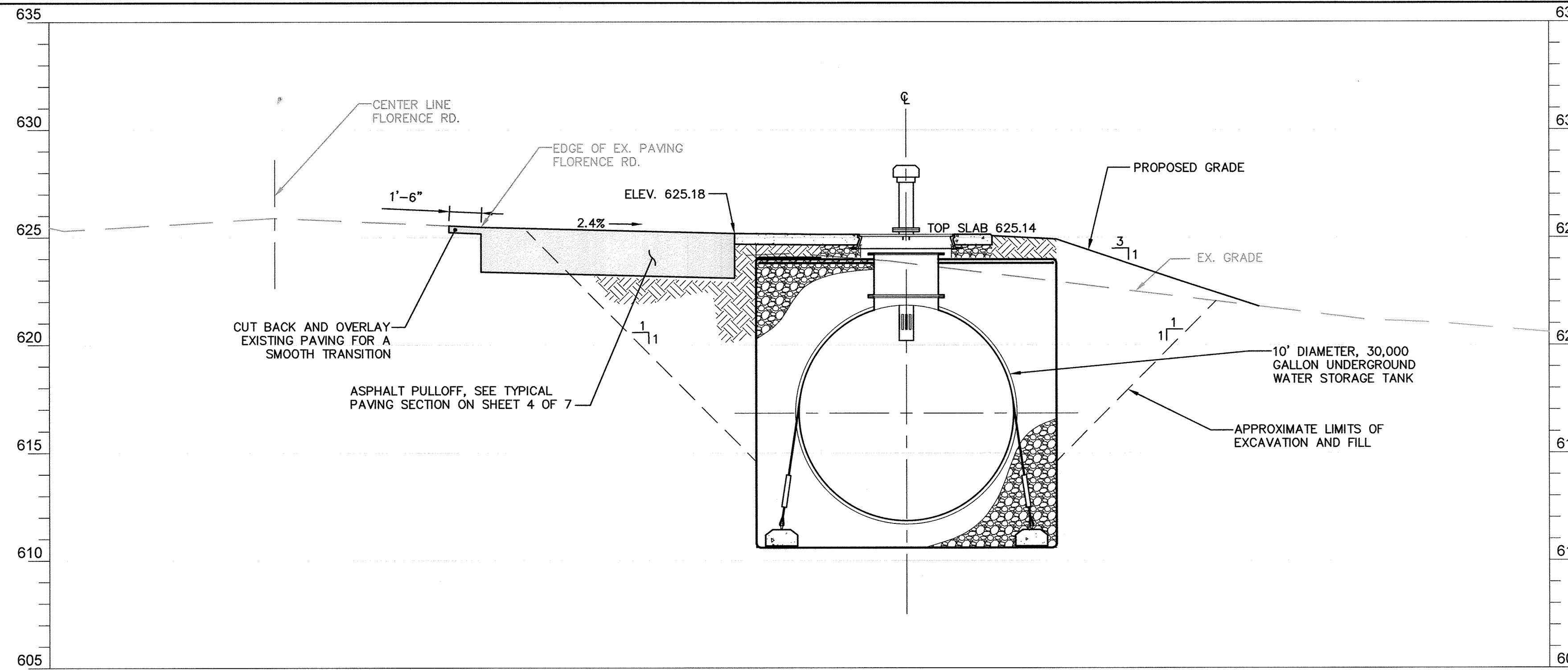

CONTROL NOTE  
THE HORIZONTAL AND VERTICAL DATUM SHOWN HEREON ARE BASED ON GPS GEODETIC HOWARD COUNTY CONTROL POINTS  
HORIZONTAL NAD 1983/07  
VERTICAL NAVD 1988

	NORTH	EAST	ELEV
12CC	599829.269	1272375.888	675.923
12CB	597303.860	1272860.629	690.346

**PROFILE A-A**  
SCALE: HORIZ - 1" = 4'  
VERT - 1" = 4'

**LEGEND**

- △ TRAVERSE POINT
- DECIDUOUS TREE
- G25 EX. MAJOR CONTOUR
- EX. MINOR CONTOUR
- OH EX. OVERHEAD WIRES
- UF EX. UNDERGROUND WIRE
- 625 PROPOSED MAJOR CONTOUR
- 624 PROPOSED MINOR CONTOUR
- SF SILT FENCE
- LOD LIMIT OF DISTURBANCE

**SITE ANALYSIS:**

TOTAL AREA OF SITE	0.114	ACRES
AREA DISTURBED	0.114	ACRES
AREA TO BE ROOFED OR PAVED	0.025	ACRES
AREA TO BE VEGETATIVELY STABILIZED	0.089	ACRES
TOTAL CUT	570	CU. YDS.
TOTAL FILL	235	CU. YDS.
OFFSITE WASTE/BORROW AREA LOCATION	CONTRACTOR COORDINATE	

**UTILITY NOTE**

THE UNDERGROUND UTILITY LOCATIONS SHOWN HEREON HAVE BEEN LOCATED FROM A COMBINATION OF FIELD SURVEY INFORMATION, AERIAL SURVEY LOCATIONS, AND/OR EXISTING DRAWINGS. THE ENGINEER MAKES NO GUARANTEE THAT THE UNDERGROUND UTILITIES SHOWN COMPRISE ALL SUCH UTILITIES IN THE AREA, EITHER IN SERVICE OR ABANDONED. THE ENGINEER FURTHER DOES NOT WARRANT THAT THE UNDERGROUND UTILITIES SHOWN ARE IN THE EXACT LOCATION INDICATED, ALTHOUGH HE DOES CERTIFY THAT THEY ARE INDICATED ON THE FOREMENTIONED INFORMATION OBTAINED BY THE ENGINEER.

THE CONTRACTOR IS RESPONSIBLE FOR CONTACTING "MISS UTILITY" 48 HOURS PRIOR TO CONSTRUCTION 1-800-257-7777.

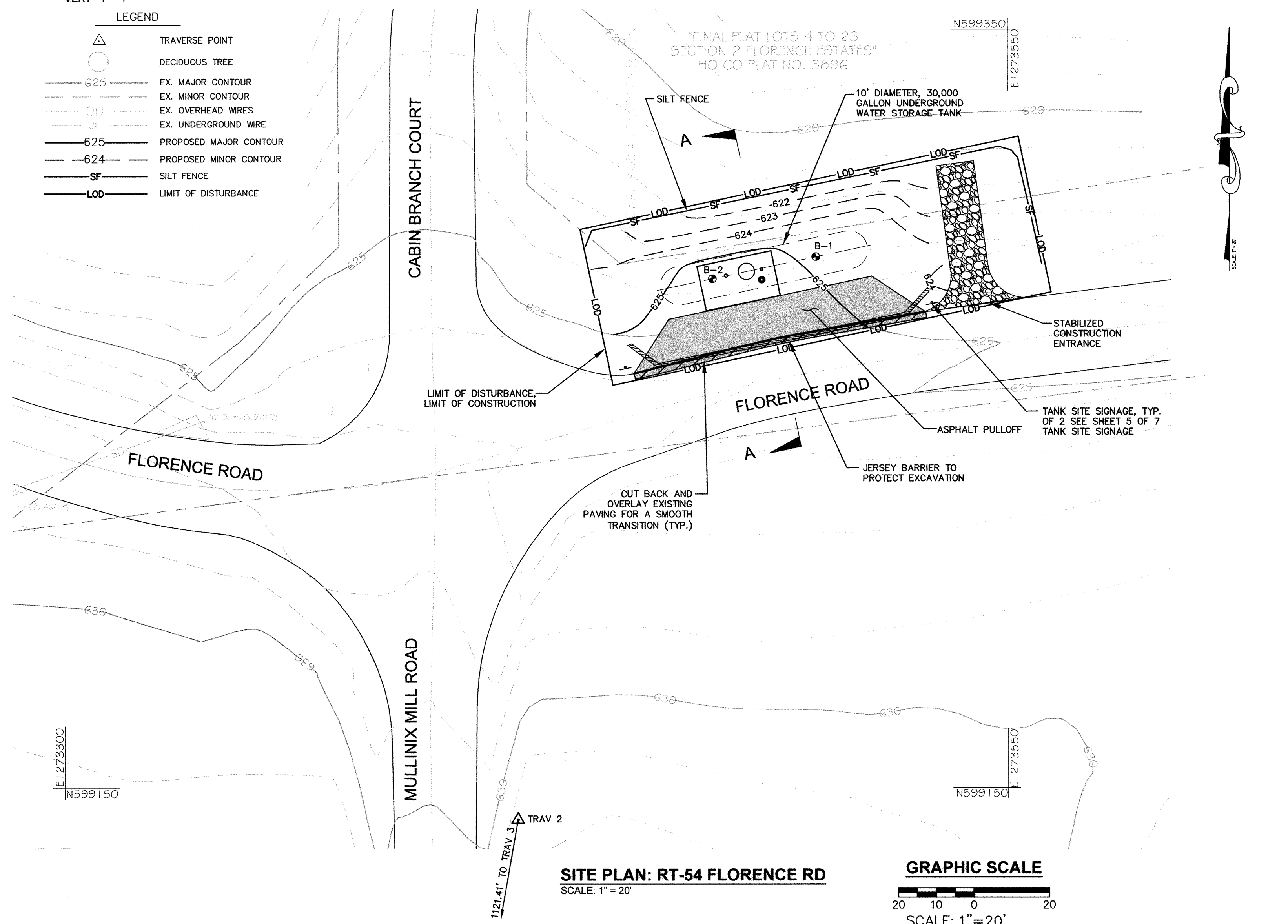

PROFESSIONAL CERTIFICATION: I hereby certify that these documents were prepared or approved by me, and that I am a duly licensed professional engineer under the laws of the State Of Maryland, License No. 31363, Expiration Date 01/16/2020.

KCI TECHNOLOGIES PROJECT No. : 13122677.38

Jan 05, 2018 - 8:00am User: newm\jackson  
file:///C:/Users/newm/Desktop/13122677.38/RT-54\_Florence\_Rd.dwg

DEPARTMENT OF PUBLIC WORKS  
HOWARD COUNTY, MARYLAND

*Jay D. Hinkle*  
DIRECTOR OF PUBLIC WORKS DATE 1/11/18

*Thomas E. Butler*  
CHIEF, BUREAU OF ENGINEERING DATE 1/11/18

*John P. ...*  
CHIEF, BUREAU OF UTILITIES DATE 1/11/18

*...*  
CHIEF, UTILITY DESIGN DIVISION DATE 1/11/18

KCI TECHNOLOGIES

ENGINEERS  
PLANNERS  
SCIENTISTS  
CONSTRUCTION MANAGERS

936 Ridgebrook Road  
Sparks, MD 21152  
Phone: (410) 316-7800  
Fax: (410) 316-7817  
www.kci.com

STATE OF MARYLAND  
GUY H. WALKER  
PROFESSIONAL ENGINEER  
No. 31363  
01/05/2018

DES: KFJ					
DRN: KFJ					
CHK: GW					
DATE: JAN. 2018	BY	NO.	REVISION	DATE	

FLORENCE ROAD  
AT  
CABIN BRANCH CT.

600' SCALE MAP NO. 12 BLOCK NO. 6

UNDERGROUND WATER STORAGE  
TANKS FOR FIRE SUPPRESSION

CAPITAL PROJECT No. F-5972  
CONTRACT No. 65-4959

ELECTION DISTRICT NO. 4 HOWARD COUNTY, MARYLAND

SCALE  
AS SHOWN  
RT54

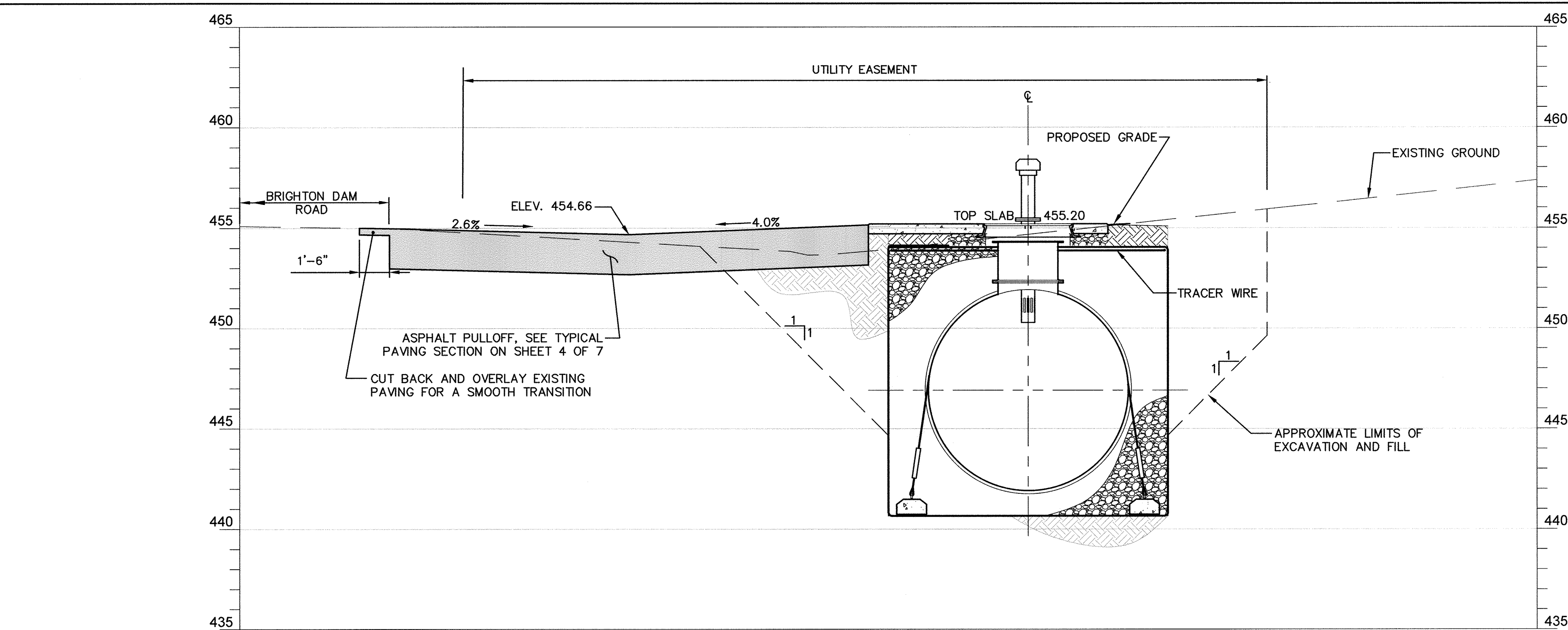
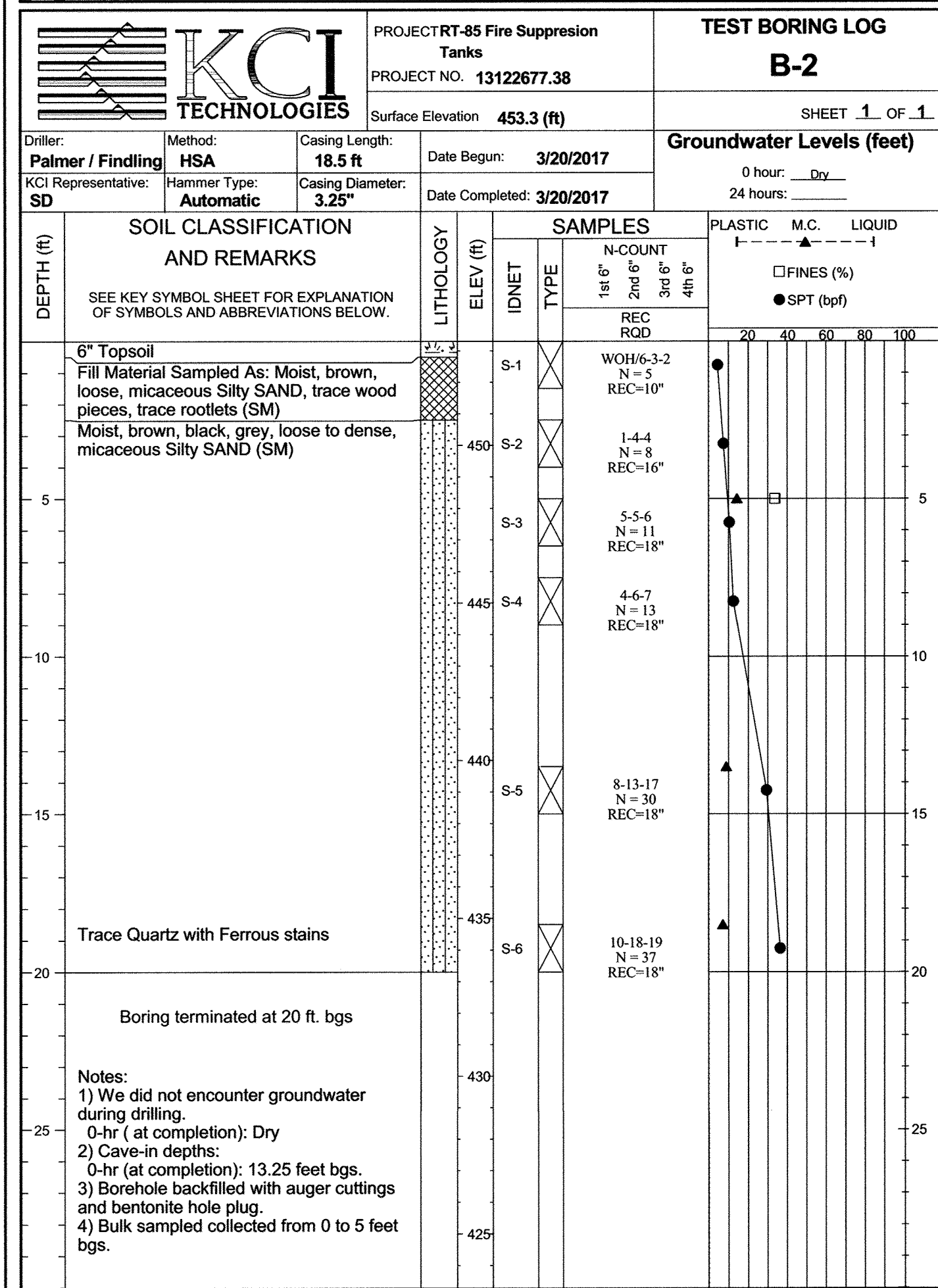
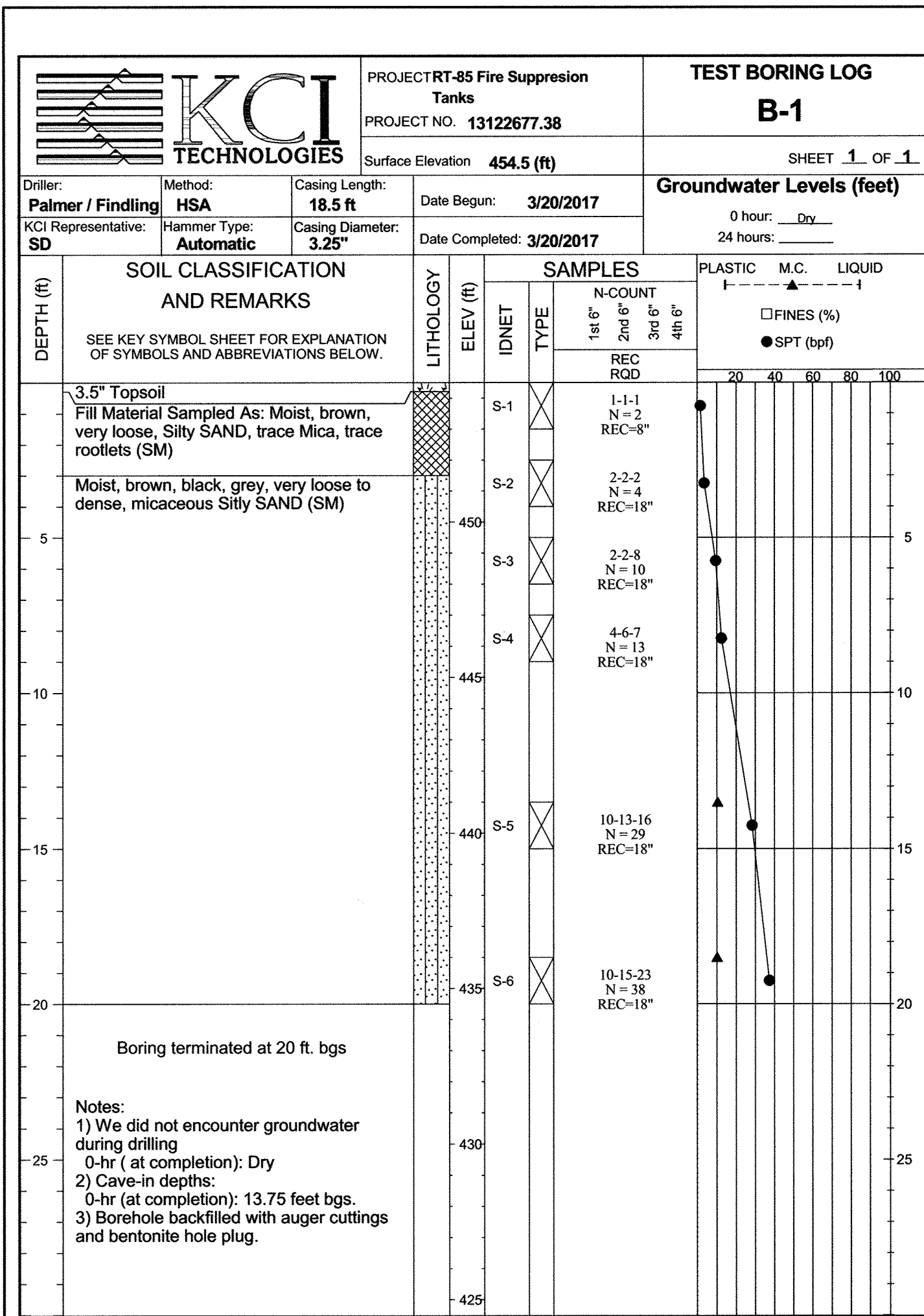

**UTILITY NOTE**

THE UNDERGROUND UTILITY LOCATIONS SHOWN HEREON HAVE BEEN LOCATED FROM A COMBINATION OF FIELD SURVEY INFORMATION, AERIAL SURVEY LOCATIONS, AND/OR EXISTING DRAWINGS. THE ENGINEER MAKES NO GUARANTEE THAT THE UNDERGROUND UTILITIES SHOWN COMPRISE ALL SUCH UTILITIES IN THE AREA, EITHER IN SERVICE OR ABANDONED. THE ENGINEER FURTHER DOES NOT WARRANT THAT THE UNDERGROUND UTILITIES SHOWN ARE IN THE EXACT LOCATION INDICATED, ALTHOUGH HE DOES CERTIFY THAT THEY ARE INDICATED ON THE AFOREMENTIONED INFORMATION OBTAINED BY THE ENGINEER.

THE CONTRACTOR IS RESPONSIBLE FOR CONTACTING "MISS UTILITY" 48 HOURS PRIOR TO CONSTRUCTION 1-800-257-7777.

QUANTITIES				
ITEM	UNIT	ESTIMATE	AS-BUILT	MANUFACTURER
30,000 GALLON WATER STORAGE TANK, COMPLETE IN PLACE, WITH PIPING CONNECTIONS PER TABLE 1, SHEET 5 OF 7	EA.	1		
ASPHALT PAVING	SF	1464		
CONCRETE SLAB	SF	240		
REMOVE EX. FENCE	LF	102		
INSTALL NEW FENCE	LF	132		

NAME OF UTILITY CONTRACTOR: \_\_\_\_\_

CHECKBOX  
 AS-BUILT DATE \_\_\_\_\_  
 SURVEY AND DRAFTING DIVISION

**NOTES:**

- FOR GENERAL TANK INSTALLATION, PIPING, SPECIFICATIONS, AND DETAILS REFER TO SHEETS 1-7 OF 7, INCLUSIVE.
- ALL TREES AND PLANTINGS INTERFERING WITH EXCAVATION SHALL BE REMOVED REPLACED WITH VIABLE TREES OF SIMILAR SPECIES. TREES AND PLANTINGS THAT ARE NOT CALLED OUT ON THE PLANS AND NEED TO BE REMOVED FOR CONSTRUCTION SHALL BE IDENTIFIED TO THE HOWARD COUNTY INSPECTOR PRIOR TO REMOVAL.
- THE CONTRACTOR SHALL TAKE ALL REASONABLE MEANS POSSIBLE TO PROTECT EXISTING TREES AND PLANTINGS WITHIN THE CONSTRUCTION AREA, AND SHALL REPLACE IN KIND THOSE DAMAGED OR REMOVED DURING CONSTRUCTION.
- EROSION AND SEDIMENT CONTROL MEASURES SHALL BE INSTALLED IN ACCORDANCE WITH THE HOWARD COUNTY DESIGN MANUAL VOLUME IV, LATEST EDITION.
- CONTRACTOR IS RESPONSIBLE FOR ACQUIRING ALL STAGING AREAS TO BE USED DURING CONSTRUCTION.
- THERE SHALL BE NO STOCKPILING OF EXCAVATED MATERIAL ON THE WORK SITE.
- ALL SURVEY STAKEOUT IS THE RESPONSIBILITY OF THE CONTRACTOR.
- ALL TANK EXCAVATIONS MUST MEET OSHA REQUIREMENTS.
- THE CONTRACTOR SHALL USE JERSEY BARRIERS TO PROTECT THE EXCAVATION. (SEE DETAIL MD 104.01-23B)(11:1 MAX TAPER)
- USE MD 104.06-18 FOR WORKZONE SIGNING.
- USE MD 104.01-71 FOR CRASH CUSHION DETAIL. USE 30mph AS DESIGN SPEED.
- ROAD WORK 1500R. SIGN CAN BE ELIMINATED WHEN THE LENGTH OF ROAD IS LESS THAN 1500R.
- PRIOR TO CONSTRUCTION, THE CONTRACTOR SHALL SCHEDULE A MEETING WITH HOWARD COUNTY TRAFFIC CONTROL MANAGER FOR THE APPROVAL OF MOT PLANS.

STAKEOUT TABLE			
DESCRIPTION	NORTHING	EASTING	ELEV
TRAV 3 (REBAR AND CAP)	556802.0105	1311542.0310	456.455
TRAV 5 (REBAR AND CAP)	556824.8165	1311302.4540	459.640
BORING B-1	556772	1311522	454.5
BORING B-2	556746	1311511	453.3
NW CORNER ASPHALT DRIVEWAY	556785.74	1311523.22	455.03
N CENTRAL CORNER ASPHALT DRIVEWAY	556781.11	1311534.29	455.65
NE CORNER ASPHALT DRIVEWAY	556787.55	1311549.99	457.00
SW CORNER ASPHALT DRIVEWAY	556735.00	1311502.00	454.03
S CENTRAL CORNER ASPHALT DRIVEWAY	556730.37	1311513.07	453.35
SE CORNER ASPHALT DRIVEWAY	556714.67	1311519.51	453.13
NW CORNER CONCRETE SLAB	556767.46	1311502.47	455.20
NE CORNER CONCRETE SLAB	556762.83	1311513.54	455.20
SW CORNER CONCRETE SLAB	556749.01	1311494.75	455.20
SE CORNER CONCRETE SLAB	556744.38	1311505.82	455.20
CENTER OF TANK MANWAY	556759.00	1311503.26	455.20

SITE ANALYSIS:	
TOTAL AREA OF SITE	0.141 ACRES
AREA DISTURBED	0.141 ACRES
AREA TO BE ROOFED OR PAVED	0.039 ACRES
AREA TO BE VEGETATIVELY STABILIZED	0.102 ACRES
TOTAL CUT	693 CU. YDS.
TOTAL FILL	544 CU. YDS.
OFFSITE WASTE/BORROW AREA LOCATION	CONTRACTOR COORDINATE

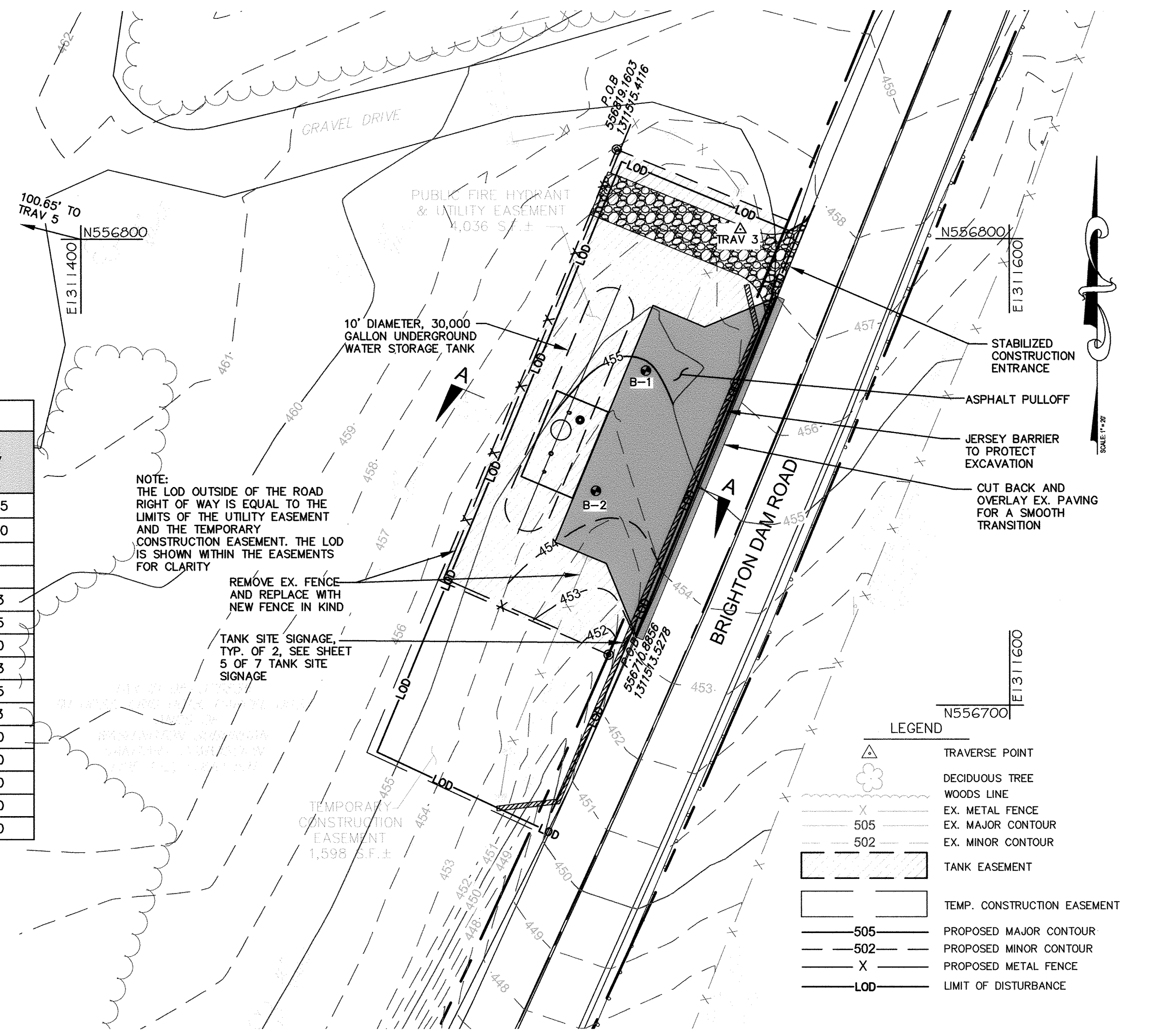

FOR LOCATION OF UTILITIES CALL 1-800-257-7777 OR LOG ON TO <http://www.missutility.net/tic/>  
 48 HOURS IN ADVANCE OF ANY WORK IN THIS VICINITY

PROFESSIONAL CERTIFICATION. I hereby certify that these documents were prepared or approved by me, and that I am a duly licensed professional engineer under the laws of the State of Maryland, License No. 31363, Expiration Date 01/16/2018.

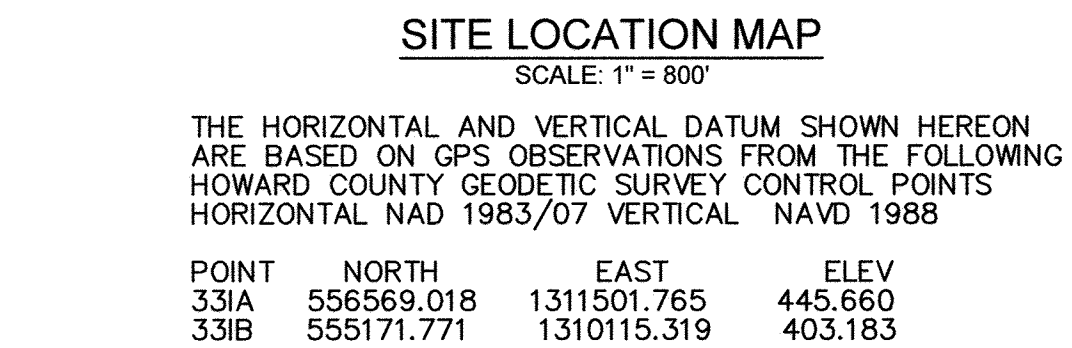

THE HORIZONTAL AND VERTICAL DATUM SHOWN HEREON ARE BASED ON GPS OBSERVATIONS FROM THE FOLLOWING HOWARD COUNTY GEODETIC SURVEY CONTROL POINTS  
 HORIZONTAL NAD 1983/07 VERTICAL NAVD 1988

POINT	NORTH	EAST	ELEV
33IA	556569.018	1311501.765	445.660
33IB	555171.771	1310115.319	403.183

KCI TECHNOLOGIES PROJECT NO. 13122677.38

JUN 01, 2017, 7:49am User: hvern.jackson  
 All rights reserved. No part of this document may be reproduced without written permission from KCI Technologies, Inc.

DEPARTMENT OF PUBLIC WORKS  
 HOWARD COUNTY, MARYLAND

*[Signature]* DATE: 6/12/17  
 DIRECTOR OF PUBLIC WORKS

*[Signature]* DATE: 6/12/17  
 CHIEF, UTILITY DESIGN DIVISION

ENGINEERS  
 PLANNERS  
 SCIENTISTS  
 CONSTRUCTION MANAGERS

**KCI TECHNOLOGIES**  
 936 Ridgebrook Road  
 Sparks, MD 21152  
 Phone: (410) 316-7900  
 Fax: (410) 316-7817  
 www.kci.com

STATE OF MARYLAND  
 PROFESSIONAL ENGINEER  
 License No. 31363  
 6/01/2017

DES.	DRN.	CHK.	DATE:	BY	NO.	REVISION	DATE
KFJ	KFJ	GW	JUNE, 2017				

**BRIGHTON DAM ROAD**

600' SCALE MAP NO. 33 BLOCK NO. 18

**UNDERGROUND WATER STORAGE TANKS FOR FIRE SUPPRESSION**

CAPITAL PROJECT No. F-5972  
 CONTRACT No. 65-4959

ELECTION DISTRICT NO. 5 HOWARD COUNTY, MARYLAND

SCALE AS SHOWN  
**RT85**

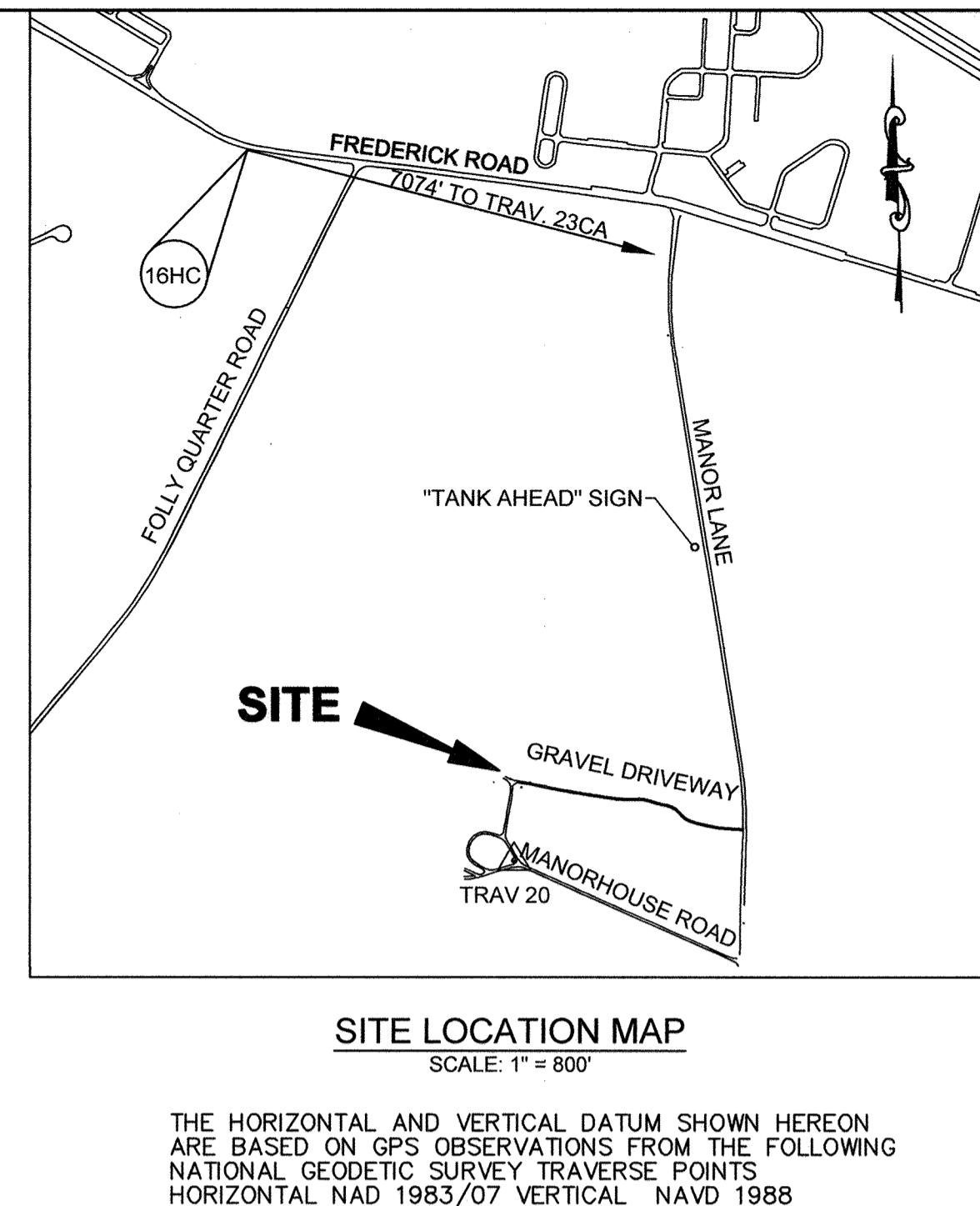
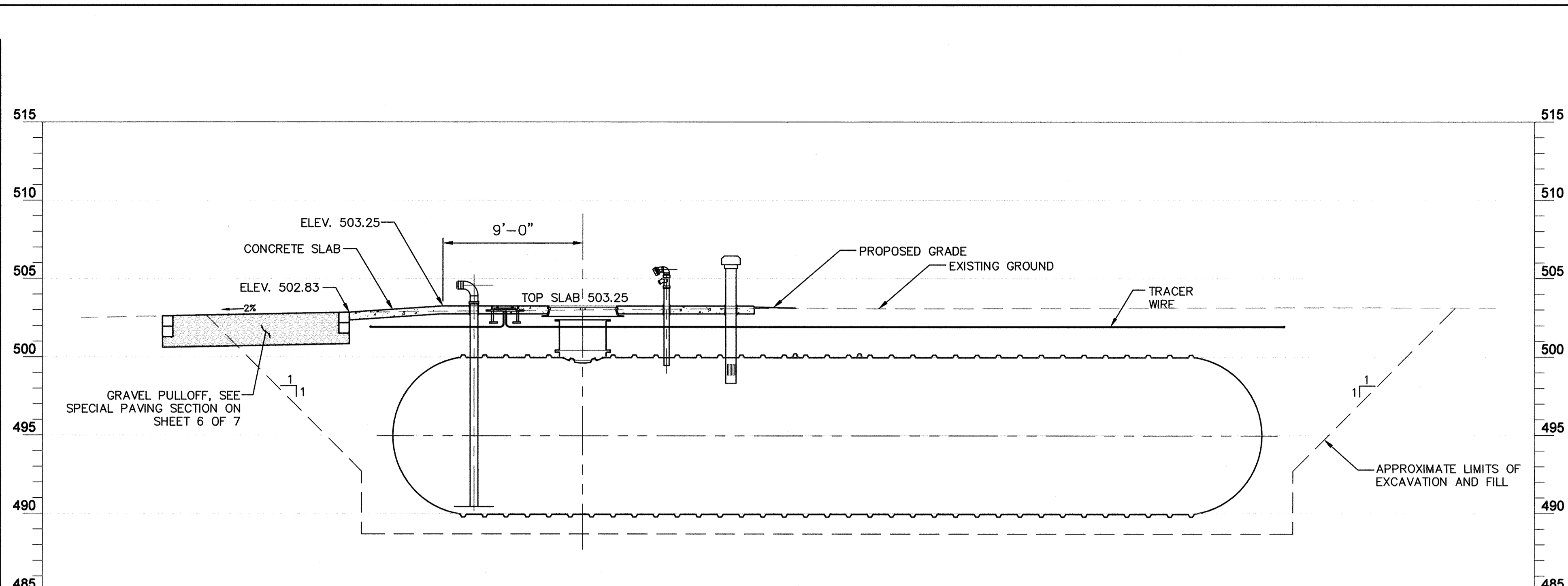
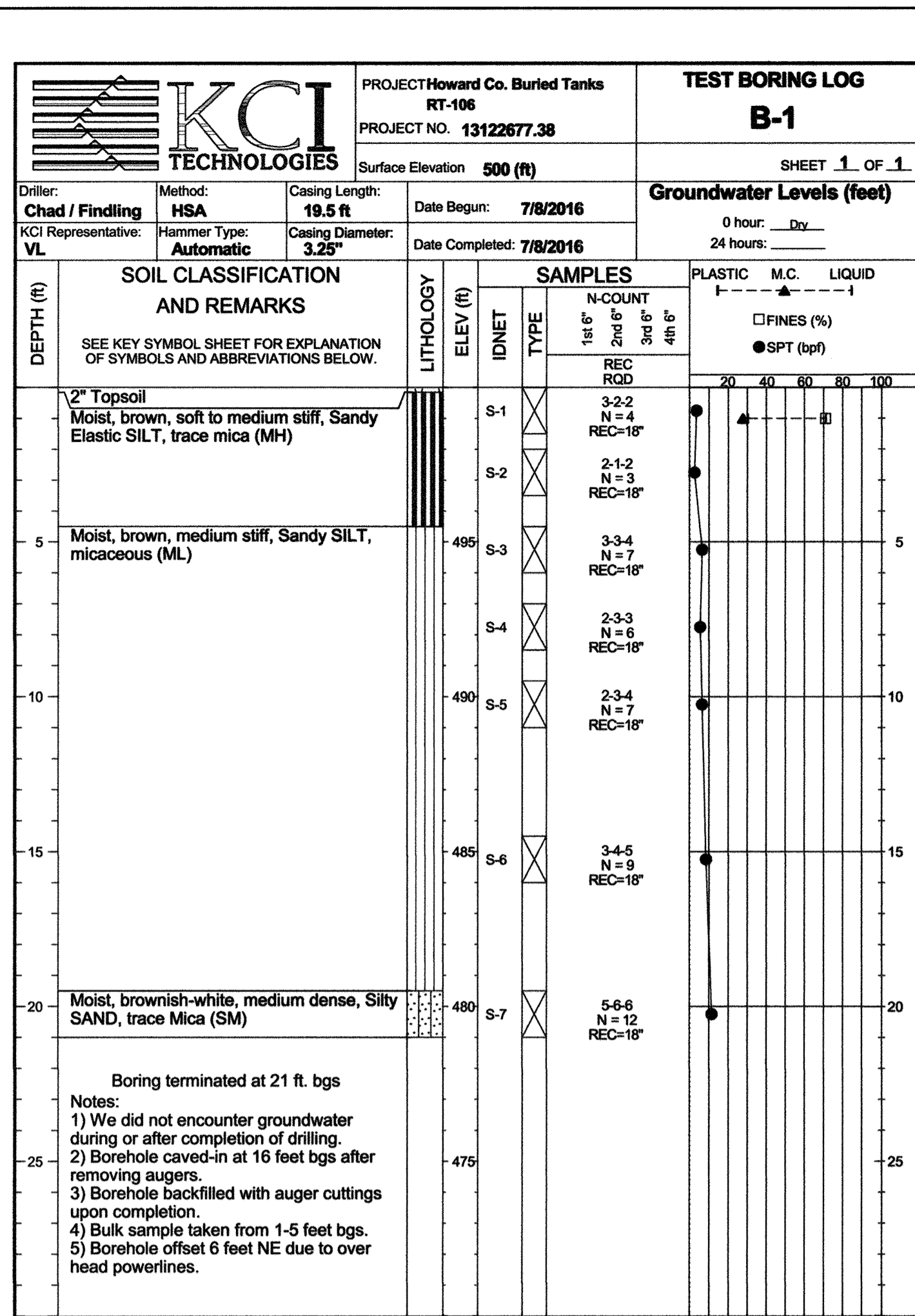

THE HORIZONTAL AND VERTICAL DATUM SHOWN HEREON ARE BASED ON GPS OBSERVATIONS FROM THE FOLLOWING NATIONAL GEODETIC SURVEY TRAVERSE POINTS  
 HORIZONTAL NAD 1983/07 VERTICAL NAVD 1988

POINT	NORTH	EAST	ELEV
16HC	589780.930	1341529.866	448.644
23CA	588035.645	1348385.607	482.187

**NOTES:**

- FOR GENERAL TANK INSTALLATION, PIPING, SPECIFICATIONS, AND DETAILS REFER TO SHEETS 1-7 OF 7, INCLUSIVE.
- ALL TREES AND PLANTINGS INTERFERING WITH EXCAVATION SHALL BE REMOVED AND REPLACED WITH VIABLE TREES OF SIMILAR SPECIES. TREES AND PLANTINGS THAT ARE NOT CALLED OUT ON THE PLANS AND NEED TO BE REMOVED FOR CONSTRUCTION SHALL BE IDENTIFIED TO THE HOWARD COUNTY INSPECTOR PRIOR TO REMOVAL.
- THE CONTRACTOR SHALL TAKE ALL REASONABLE MEANS POSSIBLE TO PROTECT EXISTING TREES AND PLANTINGS WITHIN THE CONSTRUCTION AREA, AND SHALL REPLACE IN KIND THOSE DAMAGED OR REMOVED DURING CONSTRUCTION.
- EROSION AND SEDIMENT CONTROL MEASURES SHALL BE INSTALLED IN ACCORDANCE WITH THE HOWARD COUNTY DESIGN MANUAL VOLUME IV, LATEST EDITION.
- CONTRACTOR IS RESPONSIBLE FOR ACQUIRING ALL STAGING AREAS TO BE USED DURING CONSTRUCTION.
- ALL SURVEY STAKEOUT IS THE RESPONSIBILITY OF THE CONTRACTOR.

**STAKEOUT TABLE**

DESCRIPTION	NORTHING	EASTING	ELEV
TRAV 20 (REBAR AND CAP)	586254.20	1342862.73	500.32
TRAV 21 (REBAR AND CAP)	586620.03	1342899.14	504.76
BORING B-1	586675	1342898	503.2
BORING B-2	586681	1342870	502.9
NW CORNER GRAVEL DRIVEWAY	586711.05	1342865.82	501.52
NE CORNER GRAVEL DRIVEWAY	586708.20	1342879.53	501.62
SW CORNER GRAVEL DRIVEWAY	586670.34	1342857.38	503.38
SE CORNER GRAVEL DRIVEWAY	586667.51	1342871.09	503.44
SW CORNER GRAVEL APRON	586660.58	1342842.73	503.40
SE CORNER GRAVEL APRON	586651.98	1342879.86	504.14
NW CORNER CONCRETE SLAB	586689.45	1342875.64	503.25
NE CORNER CONCRETE SLAB	586684.17	1342901.10	503.25
SW CORNER CONCRETE SLAB	586681.62	1342874.01	503.25
SE CORNER CONCRETE SLAB	586676.33	1342899.47	503.25
TANK EASEMENT TE-1	586660.69	1342842.41	503.39
TANK EASEMENT TE-2	586663.91	1342843.07	503.47
TANK EASEMENT TE-3	586672.36	1342855.75	503.36
TANK EASEMENT TE-4	586713.41	1342864.26	501.39
TANK EASEMENT TE-5	586706.90	1342896.71	501.70
TANK EASEMENT TE-6	586691.85	1342893.59	502.52
TANK EASEMENT TE-7	586682.40	1342939.14	502.78
TANK EASEMENT TE-8	586662.82	1342935.07	503.32
TANK EASEMENT TE-9	586672.27	1342889.53	503.33
TANK EASEMENT TE-10	586651.15	1342885.14	504.13
CENTER OF TANK MANWAY	586682.49	1342889.51	503.25

**UTILITY NOTE**

THE UNDERGROUND UTILITY LOCATIONS SHOWN HEREON HAVE BEEN LOCATED FROM A COMBINATION OF FIELD SURVEY INFORMATION, AERIAL SURVEY LOCATIONS, AND/OR EXISTING DRAWINGS. THE ENGINEER MAKES NO GUARANTEE THAT THE UNDERGROUND UTILITIES SHOWN COMPRISE ALL SUCH UTILITIES IN THE AREA, EITHER IN SERVICE OR ABANDONED. THE ENGINEER FURTHER DOES NOT WARRANT THAT THE UNDERGROUND UTILITIES SHOWN ARE IN THE EXACT LOCATION INDICATED, ALTHOUGH HE DOES CERTIFY THAT THEY ARE INDICATED ON THE AFOREMENTIONED INFORMATION OBTAINED BY THE ENGINEER.

THE CONTRACTOR IS RESPONSIBLE FOR CONTACTING "MISS UTILITY" 48 HOURS PRIOR TO CONSTRUCTION 1-800-257-7777.

**QUANTITIES**

ITEM	UNIT	ESTIMATE	AS-BUILT	MANUFACTURER
30,000 GALLON WATER STORAGE TANK, COMPLETE IN PLACE, WITH PIPING CONNECTIONS PER TABLE 1, SHEET 5 OF 7	EA.	1		
GRAVEL PAVING	SF	945		
6" X 6" TREATED LANDSCAPE TIES	LF	264		
CONCRETE SLAB	SF	208		

NAME OF UTILITY CONTRACTOR: \_\_\_\_\_

CHECKBOX  
 AS-BUILT \_\_\_\_\_  
 DATE \_\_\_\_\_  
 SURVEY AND DRAFTING DIVISION

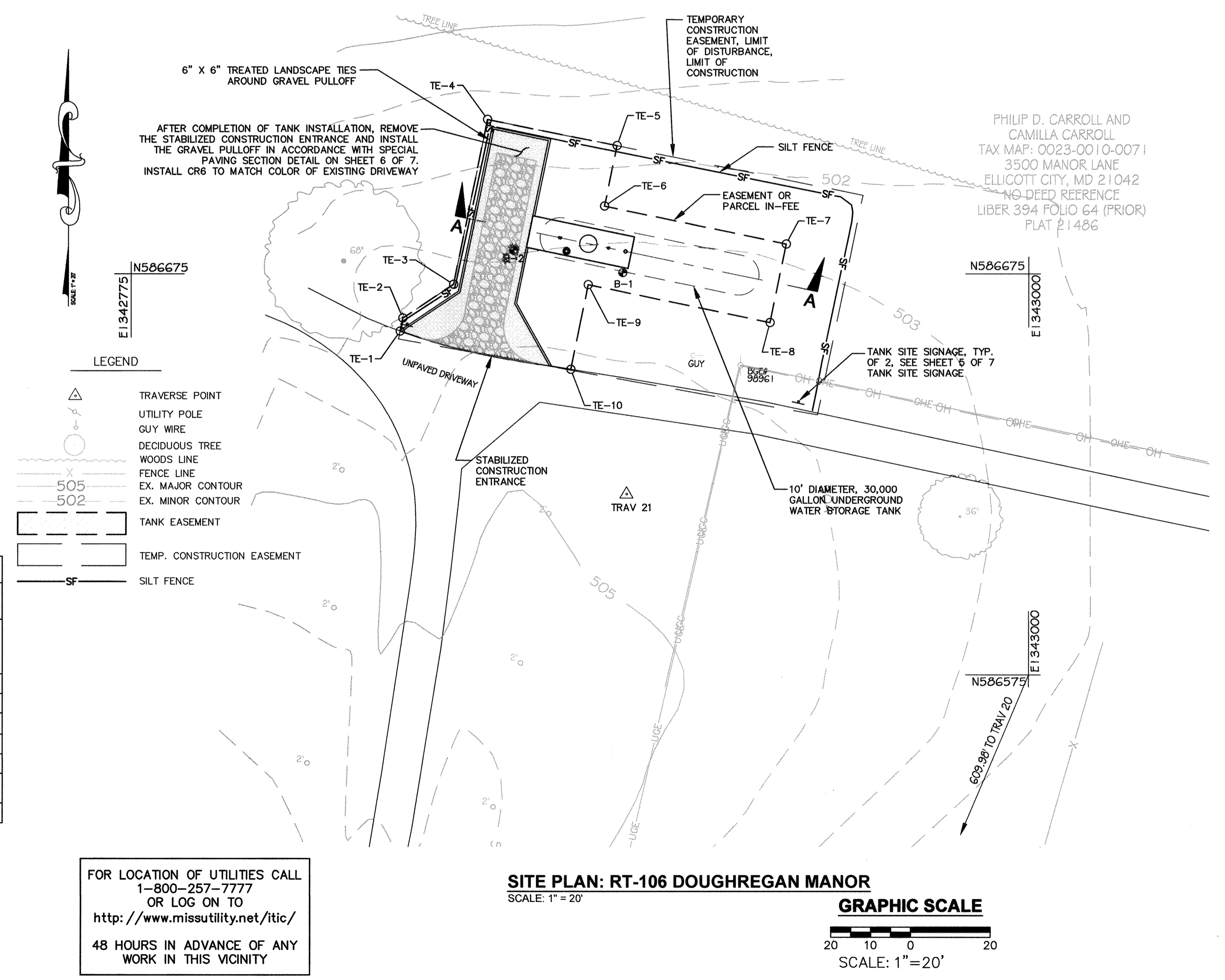

FOR LOCATION OF UTILITIES CALL 1-800-257-7777 OR LOG ON TO <http://www.missutility.net/itic/>  
 48 HOURS IN ADVANCE OF ANY WORK IN THIS VICINITY

PROFESSIONAL CERTIFICATION I hereby certify that these documents were prepared or approved by me, and that I am a duly licensed professional engineer under the laws of the State of Maryland, License No. 31363, Expiration Date 01/16/2018.

**KCI TECHNOLOGIES**  
 936 Ridgebrook Road  
 Sparks, MD 21152  
 Phone: (410) 316-7800  
 Fax: (410) 316-7817  
 www.kci.com

7/10/2017

DES:	DRN:	CHK:	DATE:	BY:	NO.:	REVISION:	DATE:	600' SCALE MAP NO.:	BLOCK NO.:
KFJ	KFJ	GW	JULY 2017					23	10

**UNDERGROUND WATER STORAGE TANKS FOR FIRE SUPPRESSION**

CAPITAL PROJECT No. F-5972  
 CONTRACT No. 65-4959

ELECTION DISTRICT NO. 3 HOWARD COUNTY, MARYLAND

SCALE AS SHOWN  
**RT106**

KCI TECHNOLOGIES PROJECT NO.: 13122677.38

KCI TECHNOLOGIES PROJECT NO.: 13122677.38

**DEPARTMENT OF PUBLIC WORKS**  
 HOWARD COUNTY, MARYLAND

Director of Public Works: \_\_\_\_\_ DATE: 7/10/17  
 Chief, Bureau of Engineering: \_\_\_\_\_ DATE: 7/10/17  
 Chief, Bureau of Utilities: \_\_\_\_\_ DATE: 7/10/17  
 Chief, Utility Design Division: \_\_\_\_\_ DATE: 7/10/17