

DATE	
BY	
SUPPLIER	
NOTE BOOK	
ALIGNMENT CHECKED	
NO. OF WAY CHECKED	
NO.	

DATE	
BY	
SUPPLIER	
NOTE BOOK	
GRADES CHECKED	
NO. OF NOTES	
NO.	

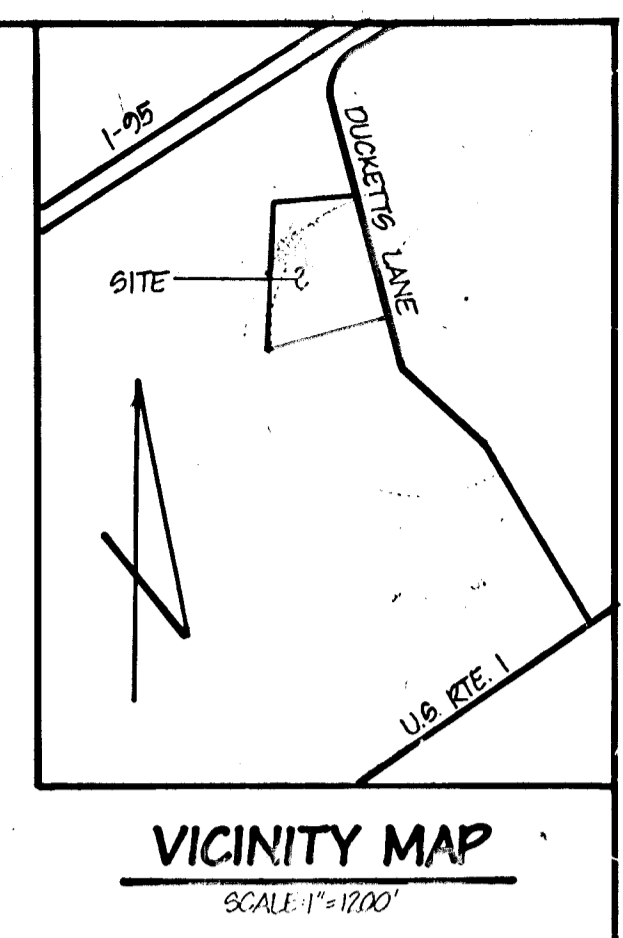
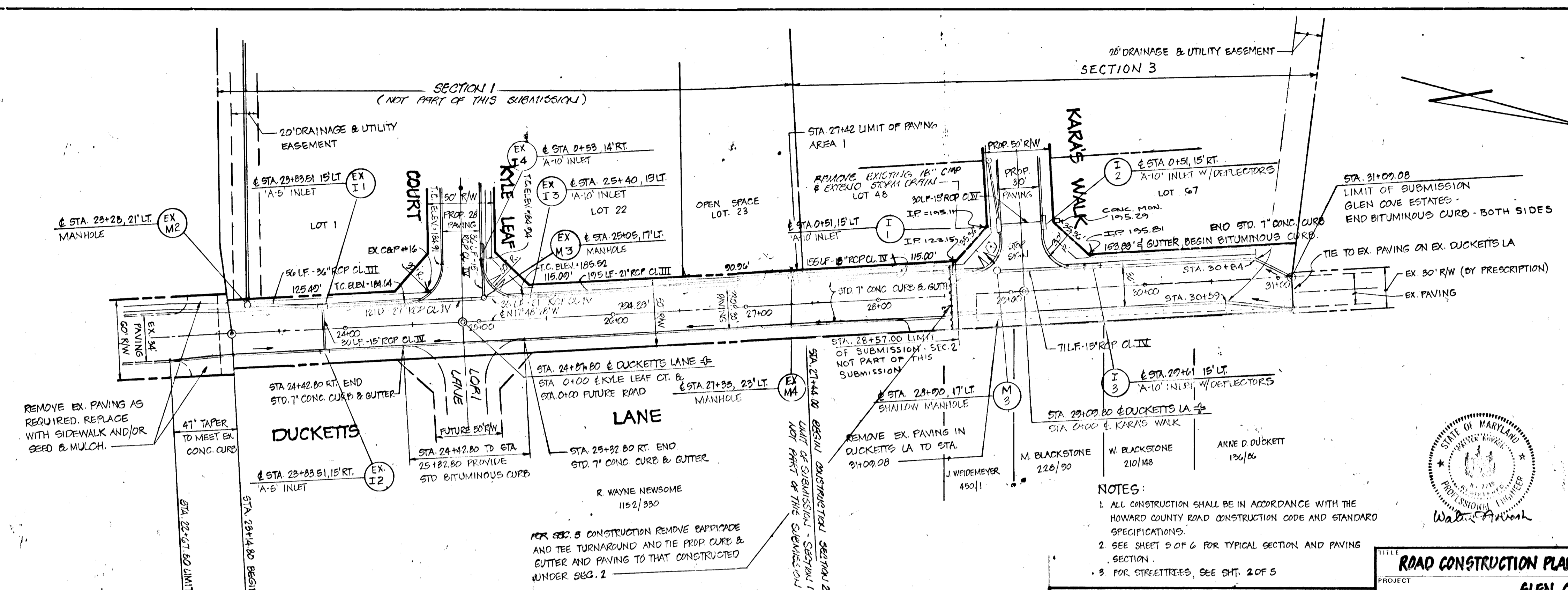

INDEX OF SHEETS

DRWG. NO.	TITLE
1 OF 5	ROAD CONSTRUCTION PLAN - DUCKETTS LANE
2 OF 5	ROAD CONSTRUCTION PLAN - KARAS WALK
3 OF 5	DRAINAGE AREA MAP, SED. CONTROL & SWIM. PLAN
4 OF 5	PROFILES AND DETAILS
5 OF 5	SWIM. SPECS AND DETAILS

PLAN
SCALE: 1" = 50'

APPROVED: DEPARTMENT OF PUBLIC WORKS
 [Signature] 11. A. R. W.
 CHIEF, BUREAU OF ENGINEERING

APPROVED: OFFICE OF PLANNING AND ZONING
 [Signature] 8-27-86
 CHIEF, DIVISION OF LAND DEVELOPMENT AND ZONING ADMINISTRATION

ROAD CONSTRUCTION PLAN - DUCKETTS LANE STA. 27+44.00 - 31+09.08
GLEN COVE ESTATES - SECTION 3

LOCATION	1ST ELECTION DISTRICT	TAX MAP 37	HOWARD COUNTY, MARYLAND
DATE:	APRIL, 1986	DESIGN BY: JJB	DRAWN BY: JJB/DMF
SCALE:	AS SHOWN	JOB NO.: 85091	DRAWING NO.: 1 OF 5
CHECKED BY:	WN		

boender associates
 3565 ELLICOTT MILLS DRIVE
 ELLICOTT CITY, MARYLAND 21043
 BALTIMORE 301 465-7777

engineers
 surveyors
 planners

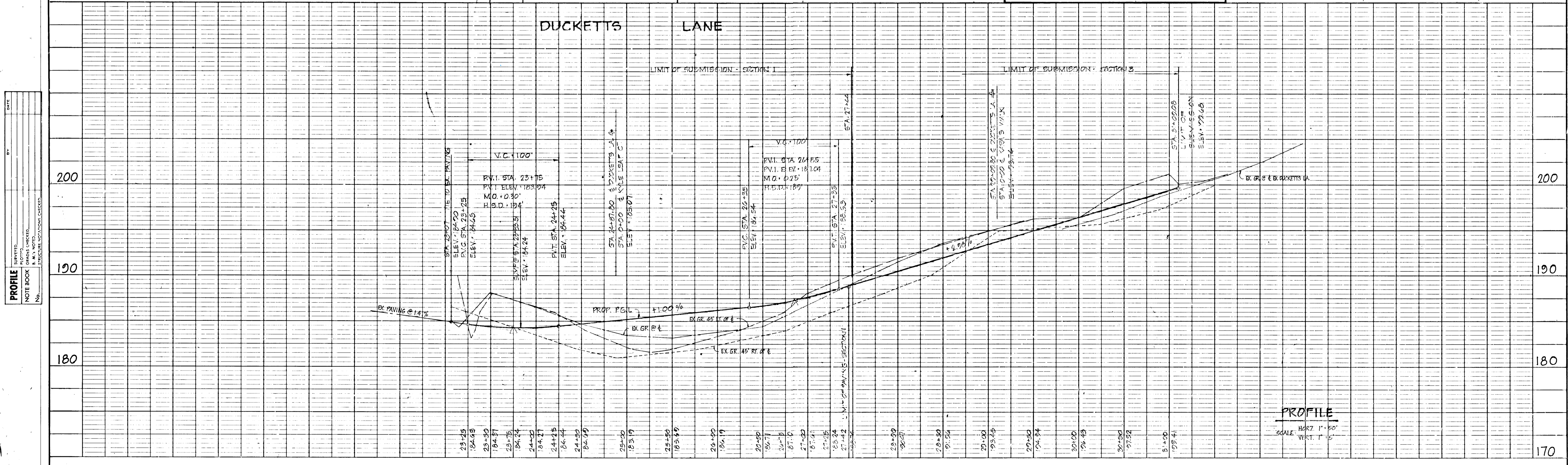

PROFILE
 SCALE: HORIZ. 1" = 50'
 VERT. 1" = 10'

DATE	
BY	
NO.	
PLAN	
NO. OF WAY CHECKED	
NO. OF SIDEWALK CHECKED	
NO. OF CURB CHECKED	
NO. OF GUTTER CHECKED	
NO. OF MANHOLE CHECKED	
NO. OF STREET LIGHT CHECKED	
NO. OF UTILITY CHECKED	

DATE	
BY	
NO.	
PROFILE	
NO. OF GRADES CHECKED	
NO. OF VERTICAL CURVES CHECKED	
NO. OF SLOPES CHECKED	
NO. OF ELEVATIONS CHECKED	

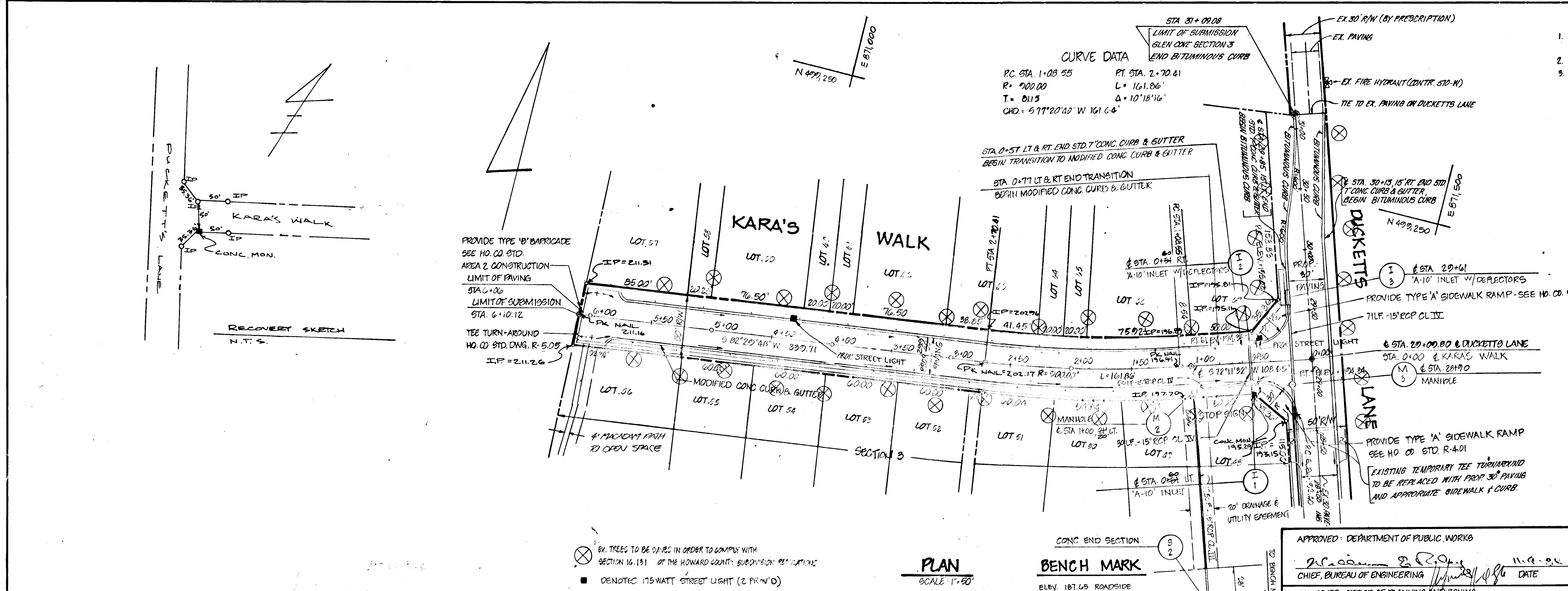

- NOTES:**
1. ALL CONSTRUCTION SHALL BE IN ACCORDANCE WITH THE HOWARD COUNTY ROAD CONSTRUCTION CODE AND STANDARD SPECIFICATIONS.
 2. SEE SHEET 5 OF 6 FOR TYPICAL SECTIONS AND PAVING SECTIONS.
 3. STOP SIGN TO BE IN ACCORDANCE WITH HO. CO. TRAFFIC ON SPEC. 1-1.

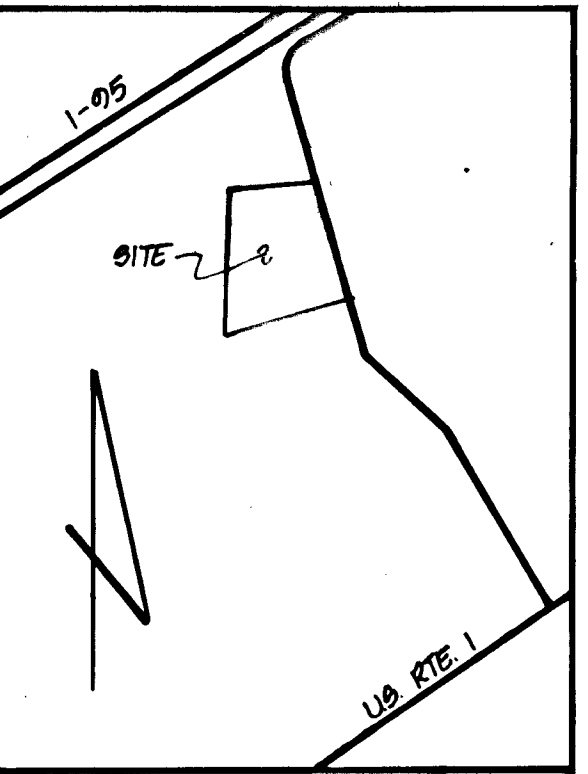

OWNER & DEVELOPER
 DUCKETT LANE ASSOCIATES
 616 WAYNE NEWSOME
 PO BOX 39
 COLUMBIA, MARYLAND 21045



ROAD CONSTRUCTION & LANDSCAPING PLAN - KARA'S WALK
GLEN COVE ESTATES - SECTION 3

PROJECT	1 RT ELECTION DISTRICT	TAX MAP 97	HOWARD COUNTY, MARYLAND
LOCATION			
DATE	APRIL, 1986	DESIGN BY: JJB	DRAWN BY: JJB/DMP
SCALE	AS SHOWN	JOB NO.: 89091	DRAWING NO.: 2 OF 5
CHECKED BY:	WN		

boender associates
 3565 ELLICOTT MILLS DRIVE
 ELLICOTT CITY, MD 21038
 BALTIMORE 301-465-7777 • SALISBURY 301-749-1286

engineers/
surveyors/
planners

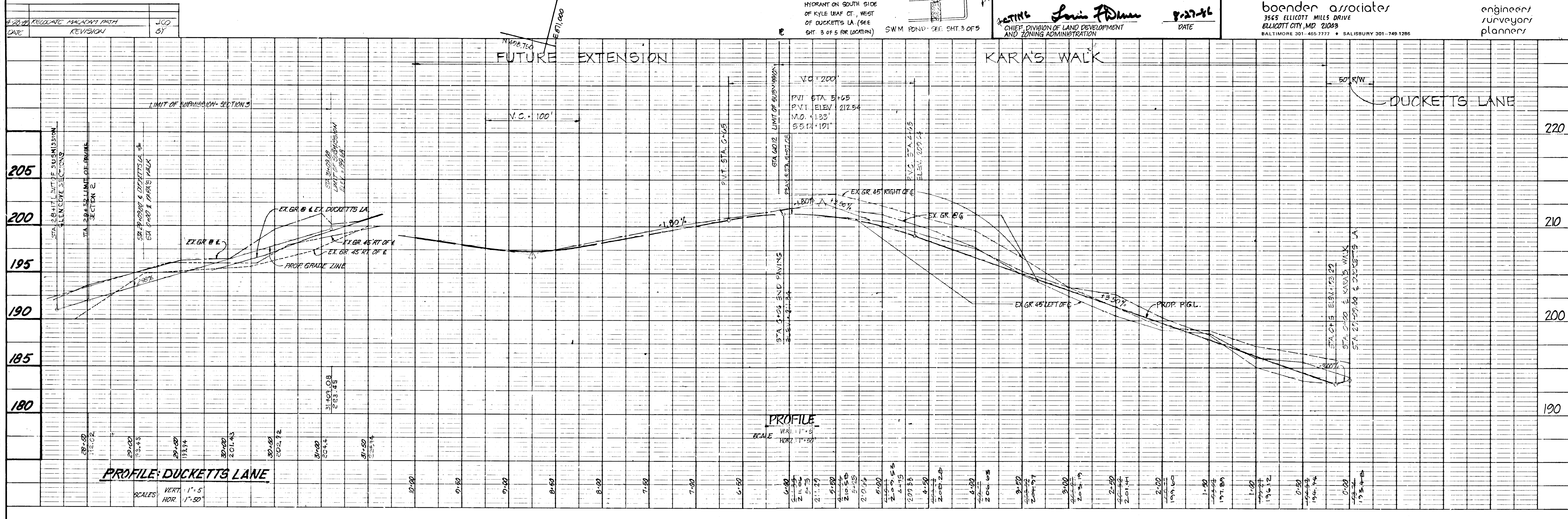

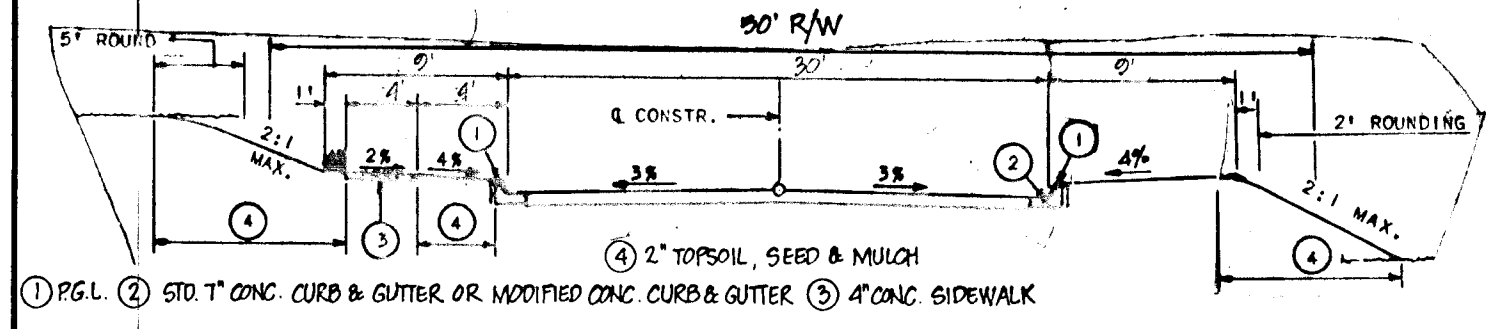

TYPICAL SECTION: DUCKETTS LA. AND KARA'S WALK

DUCKETTS LA. STA. 23+4.82 TO STA. 27+85
 LOCAL ROAD DESIGN SPEED: 30 MPH. ZONED: R-12 HO. CO. STD. DRWG. R-1-02
 NOT TO SCALE

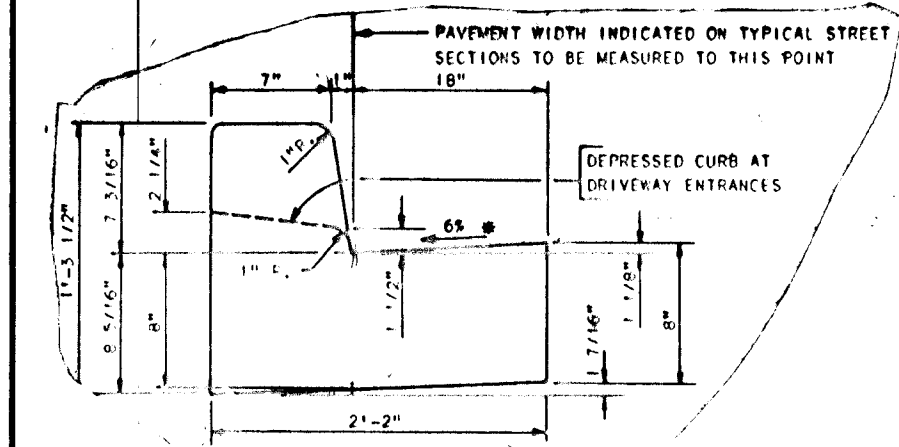

STD. 7" CONC. CURB & GUTTER

HO. CO. STD. DRWG. R-3-01 NOT TO SCALE
 BASE WILL BE PRIMED PER SECT. C-30-5 OF THE HO. CO. ROAD CONSTRUCTION CODE
 TACK COAT WILL BE REQUIRED PER SECT. C-31-4 OF THE HO. CO. ROAD CONSTR. CODE

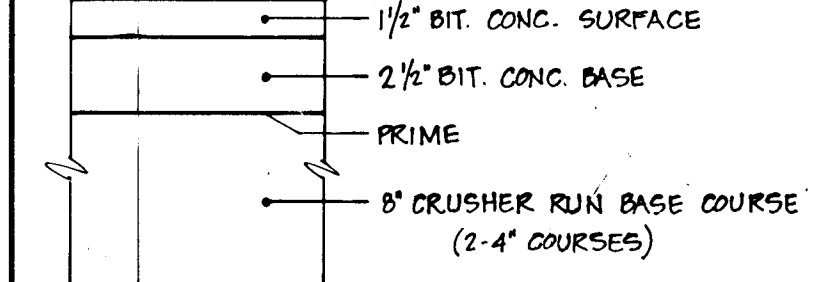

MODIFIED CONC. CURB & GUTTER

HO. CO. STD. DRWG. R-3-01 NOT TO SCALE

PAVING SECTION: P-2

HO. CO. STD. DRWG. R-2-01 NOT TO SCALE

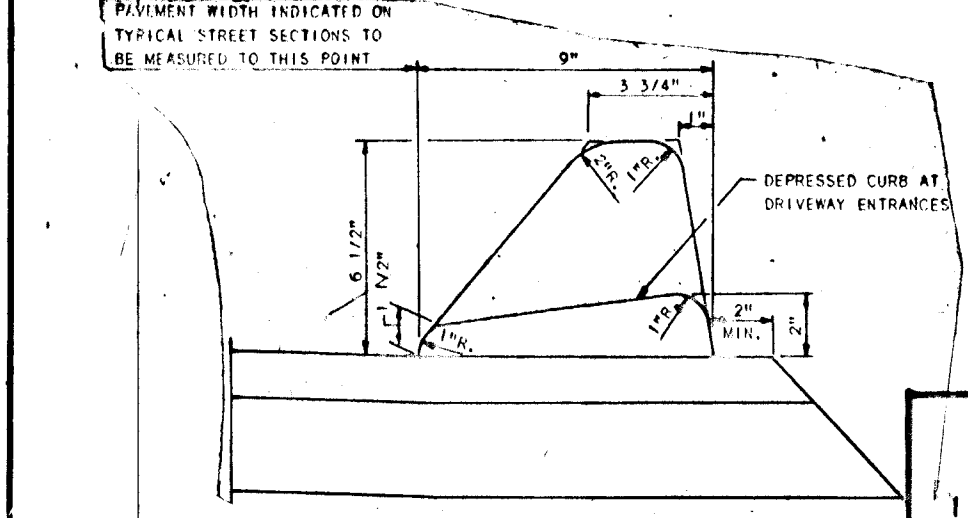

STD. BITUMINOUS CURB

HO. CO. STD. DRWG. R-3-03 NOT TO SCALE

DEVELOPERS CERTIFICATE

I CERTIFY THAT ALL DEVELOPMENT AND CONSTRUCTION WILL BE DONE ACCORDING TO THIS PLAN OF DEVELOPMENT AND PLAN FOR EROSION AND SEDIMENT CONTROL AND THAT ALL RESPONSIBLE PERSONNEL INVOLVED IN THE CONSTRUCTION PROJECT WILL HAVE A CERTIFICATE OF ATTENDANCE AT A DEPARTMENT OF NATURAL RESOURCES APPROVED TRAINING PROGRAM FOR THE CONTROL OF SEDIMENT AND EROSION BEFORE BEGINNING THE PROJECT. I ALSO AUTHORIZE PERIODIC ON-SITE INSPECTIONS BY THE HOWARD SOIL CONSERVATION DISTRICT OR THEIR AUTHORIZED AGENTS, AS ARE DEEMED NECESSARY.

Developer: Quinn M. Ruhl (agent) DATE: 7/11/86

ENGINEERS CERTIFICATE

I CERTIFY THAT THIS PLAN FOR EROSION AND SEDIMENT CONTROL REPRESENTS A PRACTICAL AND WORKABLE PLAN BASED ON PERSONAL KNOWLEDGE OF THE SITE CONDITIONS AND THAT IT WAS PREPARED IN ACCORDANCE WITH THE REQUIREMENTS OF THE HOWARD SOIL CONSERVATION DISTRICT.

Engineer: Walter J. Frank DATE: 7-12-86

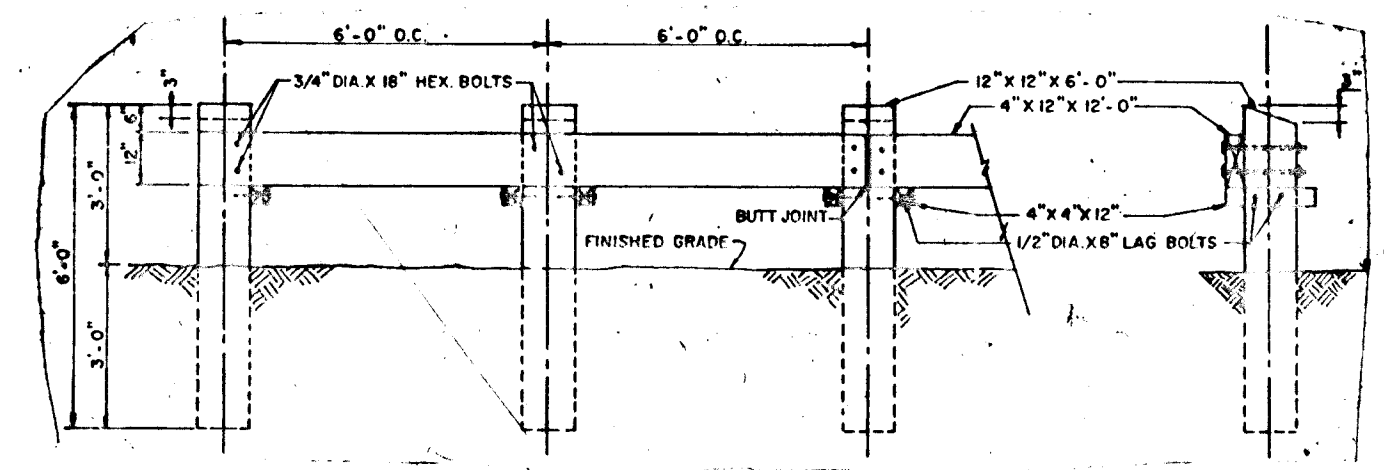

DEAD END BARRICADE - TYPE B

FOR SPECS SEE HO. CO. STD. DRWG. R-7-11 NOT TO SCALE

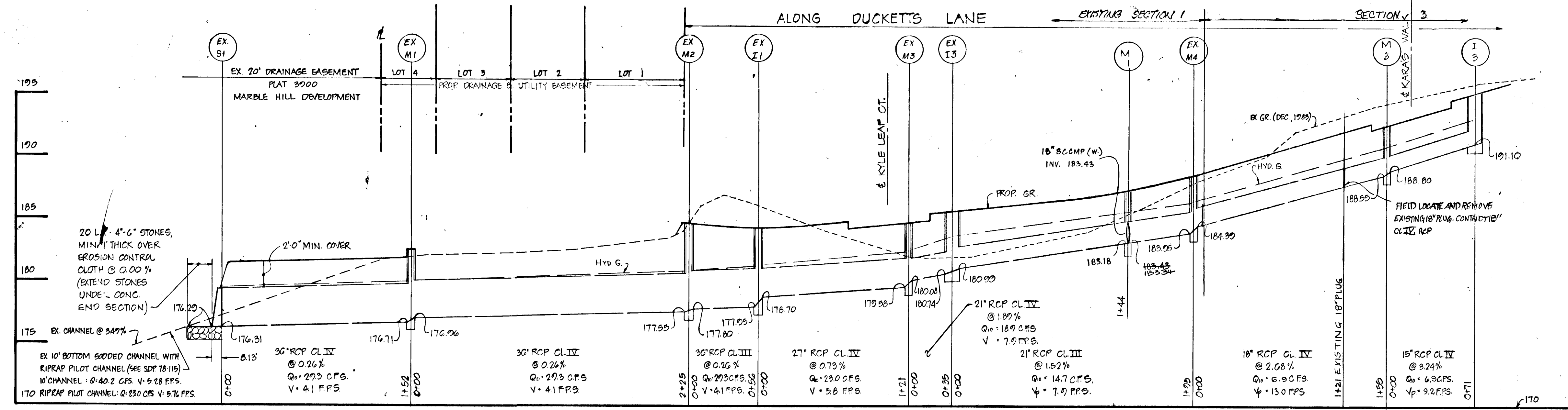

PROFILE

SCALE: HORIZ. 1" = 50'
 VERT. 1" = 5'

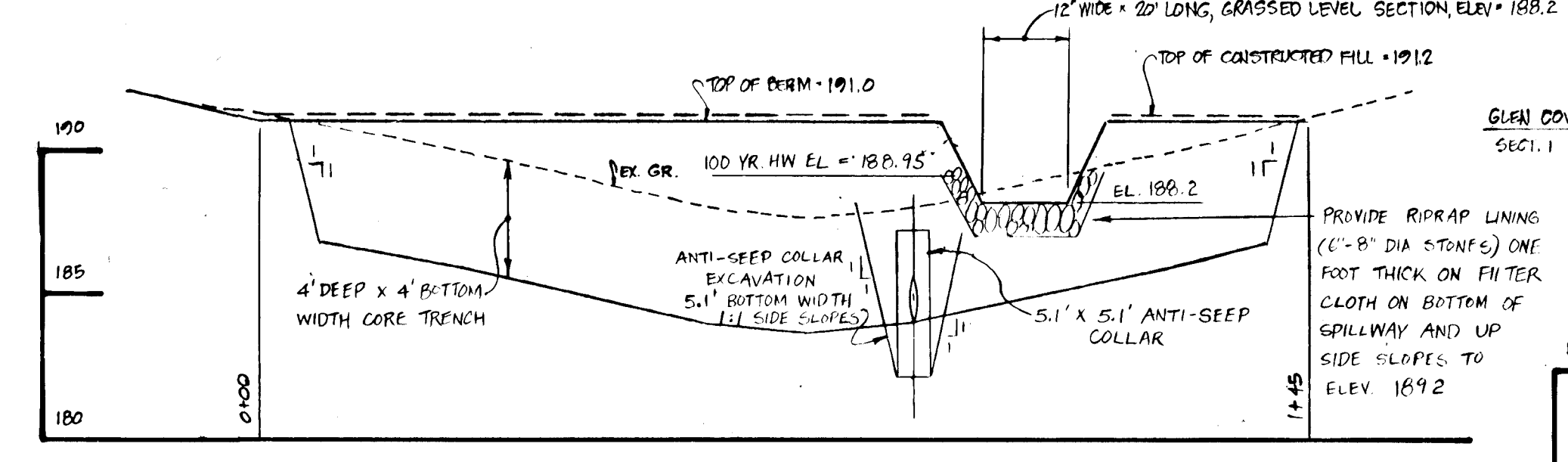

PROFILE: TOP OF BERM

SCALE: HORIZ. 1" = 20'
 VERT. 1" = 5'

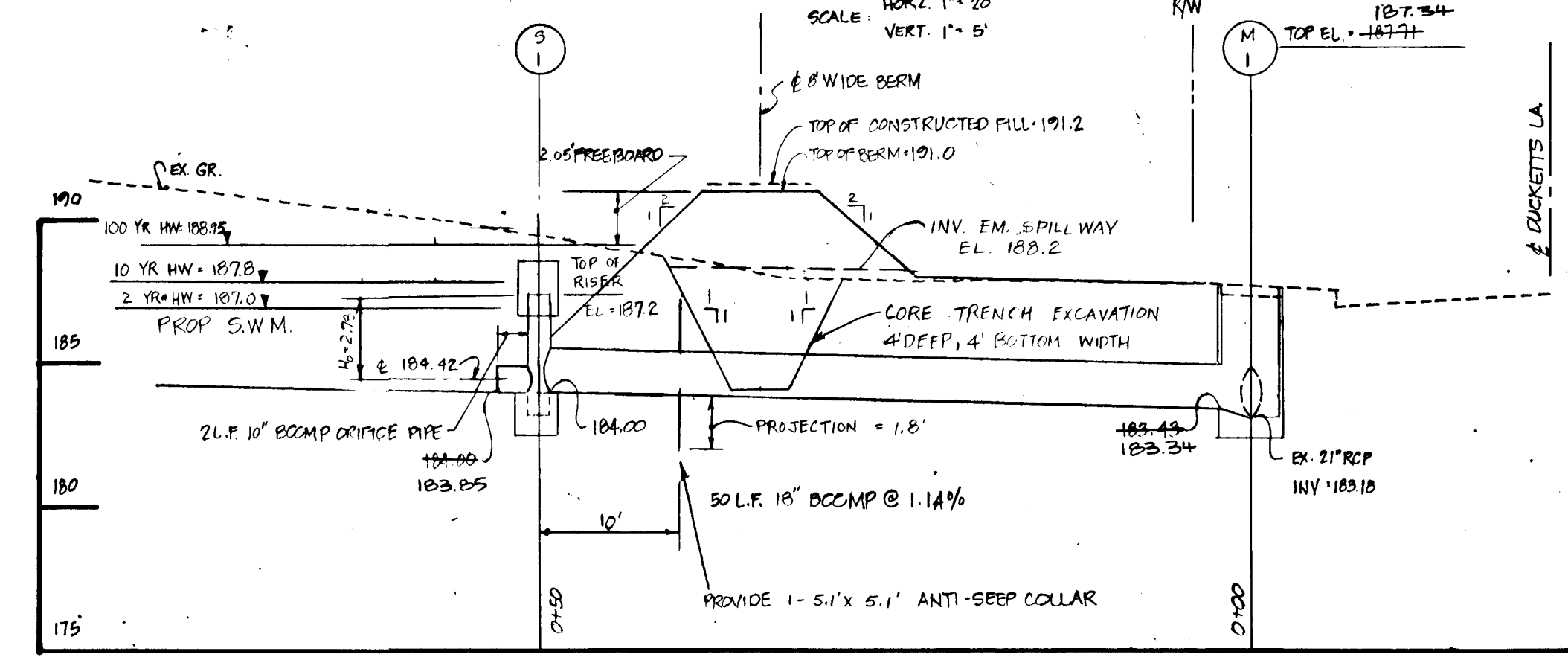

PROFILE: PRINCIPLE SPILLWAY

SCALE: HORIZ. 1" = 10'
 VERT. 1" = 5'

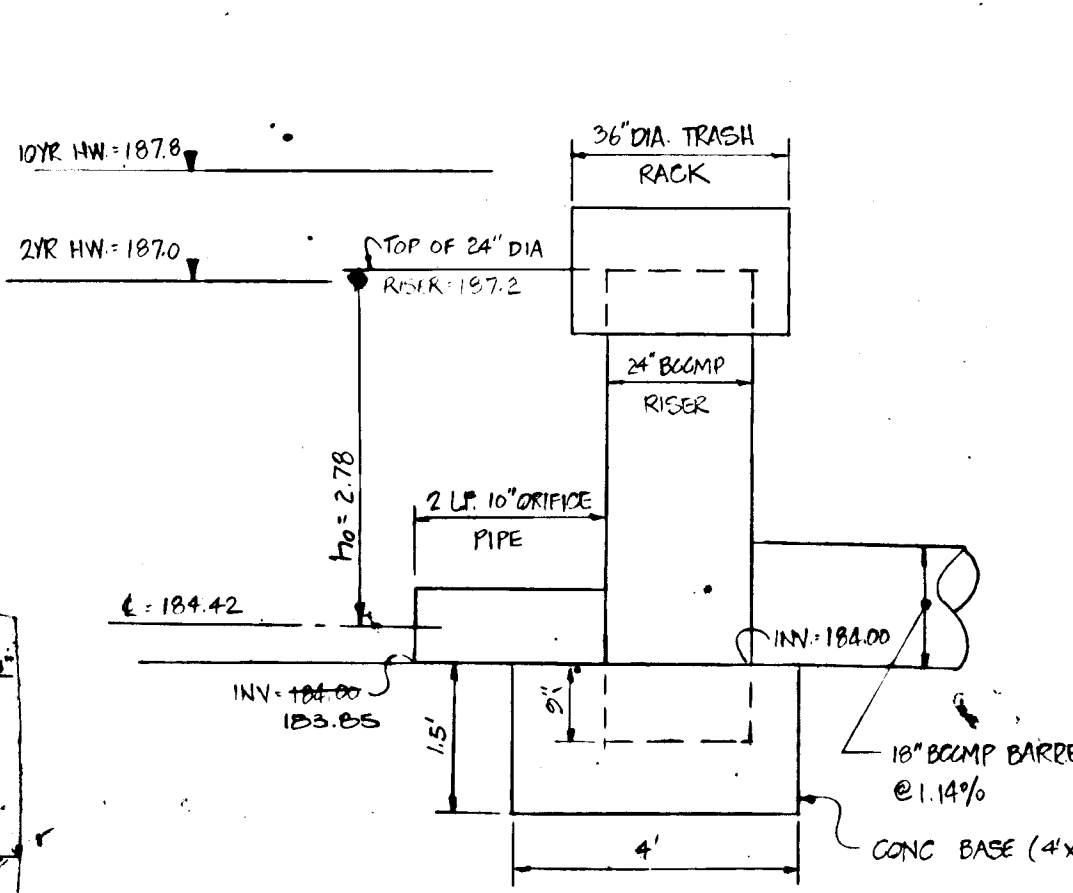

OUTLET CONTROL STRUCTURE S-1

NO SCALE

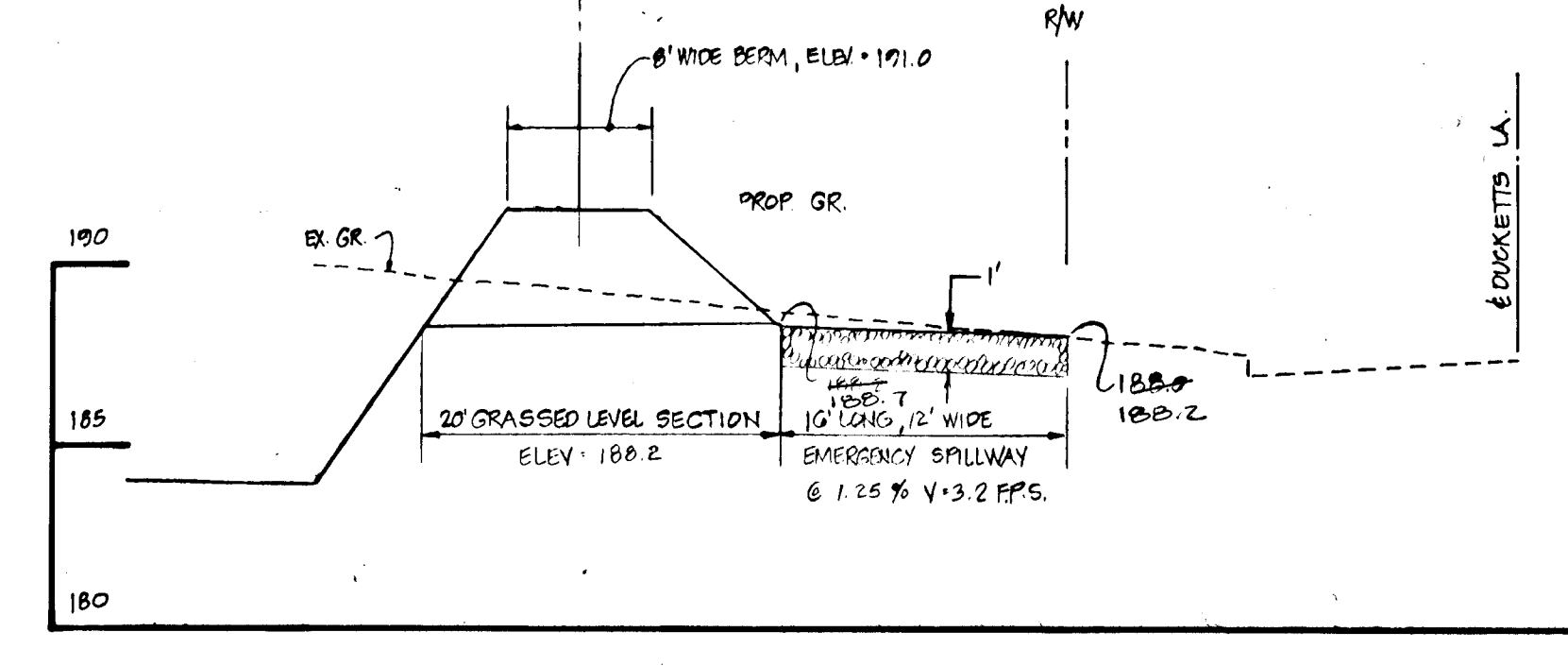

PROFILE: EMERGENCY SPILLWAY

SCALE: HORIZ. 1" = 10'
 VERT. 1" = 5'

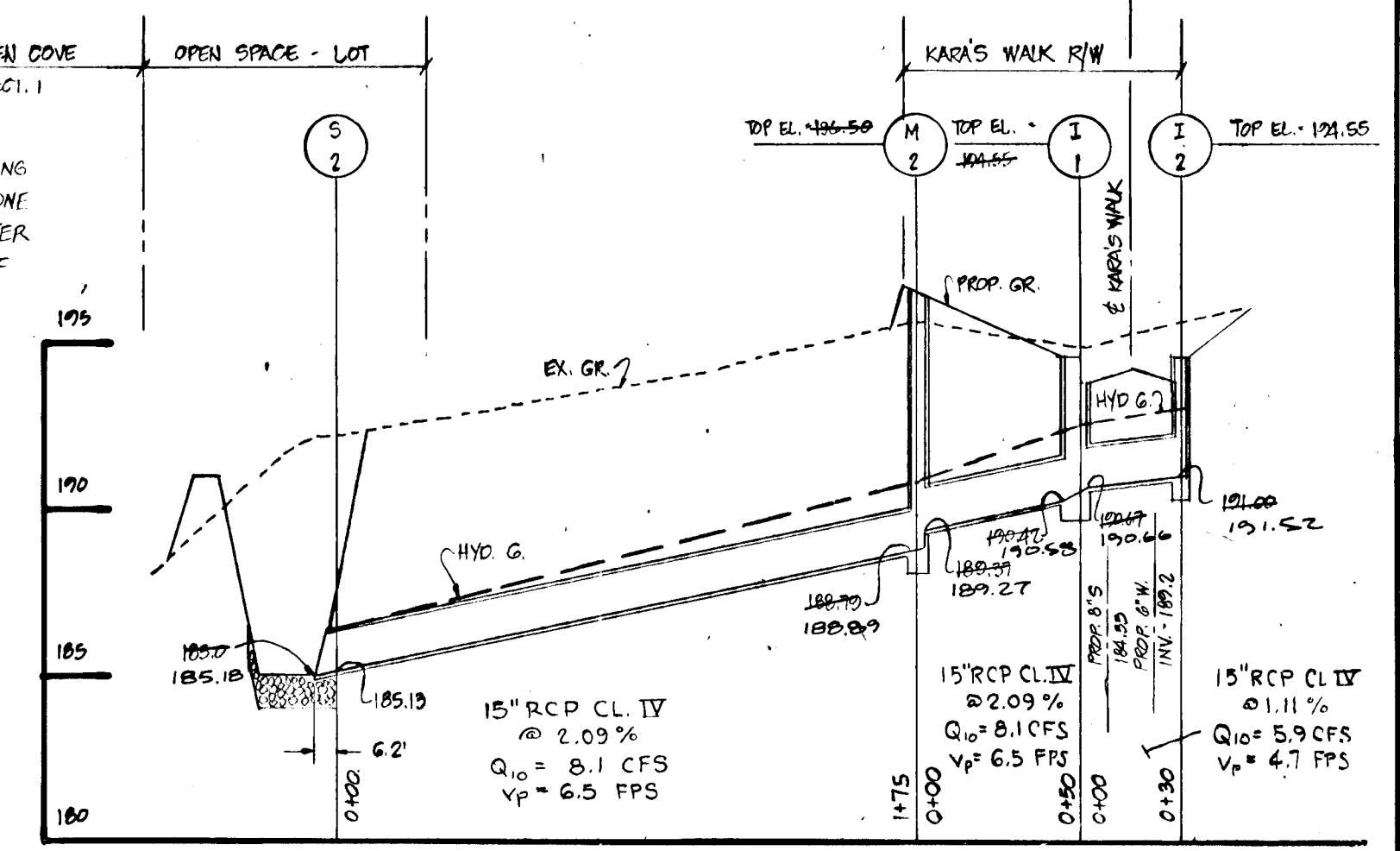

PROFILE

SCALE: HORIZ. 1" = 50'
 VERT. 1" = 5'

STRUCTURE SCHEDULE					
NO	TYPE	INV. IN	INV. OUT	TOP EL.	REMARKS
I-3	1'-10" W/DEFLECTORS	-	191.10	195.26	HO. CO. STD. DRWG. SD-4.02 & SD-4.03
I-2	1'-10" W/DEFLECTORS	-	191.52	194.62	HO. CO. STD. DRWG. SD-4.02 & SD-4.03
I-1	1'-10" INLET	190.00	190.42	194.02	HO. CO. STD. DRWG. SD-4.02
M-2	9" MANHOLE	189.27	189.79	190.50	HO. CO. STD. DRWG. G-5.01
M-1	SHALLOW MANHOLE	188.89	189.27	189.50	CONSTRUCT OVER EX. 21" RCP HO. CO. STD. DRWG. G-5.02
S-2	CONC. END SECTION	188.89	188.89	188.80	HO. CO. STD. DRWG. SD-5.51
S-1	OUTLET CONTROL STRUCTURE	188.80	188.80	188.1	
M-3	SHALLOW MANHOLE	188.80	188.55	189.55	HO. CO. STD. DRWG. G-5.05

THIS DEVELOPMENT PLAN IS APPROVED FOR SOIL EROSION AND SEDIMENT CONTROL BY THE HOWARD SOIL CONSERVATION DISTRICT.

Approved: Stephen Z. Fulmer Date: 6/27/86
 Howard S.C.D.

Approved for: Walter J. Frank P.E.
 U.S. Soil Conservation Service

OWNER & DEVELOPER
 DUCKETT LANE ASSOCIATES
 % WAYNE NEWSOME
 PO BOX 30
 COLUMBIA, MD. 21046



PROFILES & DETAILS					
PROJECT: GLEN COVE ESTATES - SECT. 3					
LOCATION	1ST ELECTION DISTRICT	DIX MAP: 31	HOWARD COUNTY, MARYLAND		
DATE	SCALE	DESIGN BY	DRAWN BY	CHECKED BY	DRAWING NO. / JOB NO.
APRIL 1986	AS SHOWN	JJB	JJB	WN	A OF 9 / 85091
boender associates			engineers		
3565 - A COURT SQUARE			surveyors		
ELLCOTT CITY, MARYLAND 21043			planners		
301-465-7177					

