

CURVE DATA
 PC 0+75.70 TO PT 2+23.70
 R=125.00
 Δ=22°00'00"
 A=48.00'
 T=24.30'
 CHD=160°34'00"W
 47.70'

CURVE DATA
 PC 2+34.76 TO PT 2+102.62
 R=125.00
 Δ=22°00'00"
 A=48.00'
 T=24.30'
 CHD=160°34'00"W
 47.70'

CURVE DATA
 PC 0+00.00 TO PT 2+130.61
 R=400.00
 Δ=20°00'00"
 A=133.85'
 T=70.64'
 CHD=82°34'00"W
 188.93'

CURVE DATA
 PC 4+01.38 TO PT 6+71.74
 R=320.00
 Δ=40°24'18"
 A=270.36'
 T=143.84'
 CHD=93°46'34"W
 262.39'

CURB & GUTTER LEGEND
 3/4" Top, 1/2" Gutter
 Rev. 7" Comb. Curb & Gutter
 5/4" 6" Comb. Curb & Gutter
 Rev. 6" Comb. Curb & Gutter

Reviewed for Howard S.C.
 Name
 And meets Technical Requirements
 Signature [Signature] Date 8-16-84
 U.S. Soil Conservation Service

THIS DEVELOPMENT PLAN IS APPROVED FOR SOIL EROSION AND SEDIMENT CONTROL BY THE HOWARD SOIL CONSERVATION DISTRICT.
 Approved: [Signature] Date: 8-16-84
 Public S.D. Utility Easement

DEVELOPER/BUILDER'S CERTIFICATE
 "I certify that all development and construction will be done according to this plan of development and plan for erosion and sediment control and that all responsible personnel involved in the construction project will have a Certificate of Attendance at a Dept. of Natural Resources Approved Training Program for the Control of Sediment and Erosion before beginning the project. I also authorize periodic on-site inspection by the Howard Soil Conservation District or their authorized agents as are deemed necessary."
[Signature]
 Signature of Developer/Builder
 Date 6/20/84

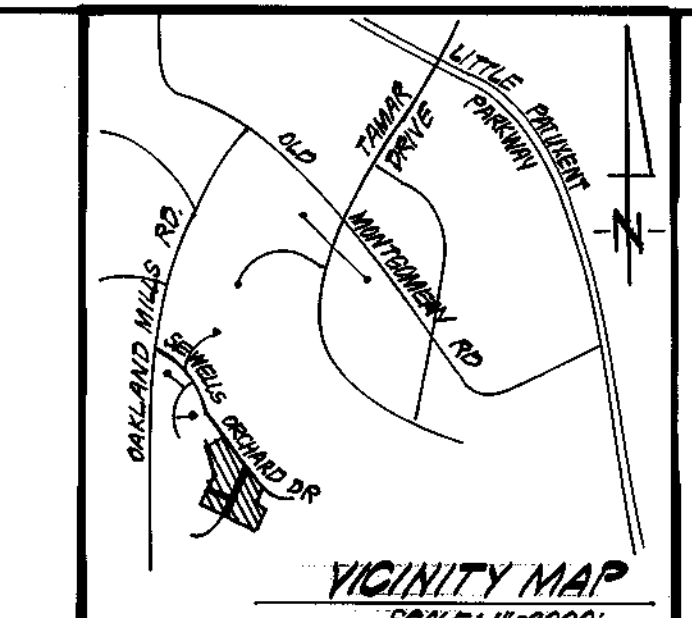

- GENERAL NOTES:**
- All storm drain and paving shall be constructed in accordance with the latest details and specifications of Howard County & Md. S.H.A.
 - Types of Storm Drain structures refer to the Standard Details of Howard County & Maryland State Highway Administration.
 - Trench Compaction for storm drains within Road or Street rights of way limits shall be in accordance with Howard Co. Design Manual, Vol. IX, Class "C" Trench Backfill to be used for all storm drains except where shown otherwise.
 - Information concerning underground utilities was obtained from available records, but the contractor must determine the exact location and elevation of the mains on dipping test pits, by hand, at all utility crossings, well in advance of construction.
 - All utility companies shall be notified 24 hrs. in advance of construction.
 - All traffic control services, parking, and signing to be done in accordance with the "Manual of Uniform Traffic Control Devices" 1971 Edition.
 - Sig and Crest Vertical Curves were designed in accordance with "A Policy on Geometric Design of Rural Highways, 1965, by AASHTO.
 - Provide Concrete Sidewalk ramps, No. Co. Std. Type A, R-4.01 where shown in plan.
 - Design Speed: 30 mph; Zones RSC
- AS-BUILT SURVEY CERTIFIED BY G. NELSON CLARK REG.-P.E. NO. 7139 ON JUNE 19, 1984

ENGINEER'S CERTIFICATE
 I hereby certify that this plan for Erosion and Sediment Control represents a practical and workable plan based on my personal knowledge of the site conditions and that it was prepared in accordance with the requirements of the Howard Soil Conservation District.
[Signature]
 G. Nelson Clark
 Date 6-19-84

APPROVED: DEPARTMENT OF PUBLIC WORKS:
[Signature] Date 8-17-84
 Chief's Bureau of Engineering
 APPROVED: HOWARD COUNTY OFFICE OF PLANNING AND ZONING
[Signature] Date 8-14-84
 Chief, Division of Land Development & Zoning Administration

CLARK FINEROCK & SACKETT
 ENGINEERS PLANNERS SURVEYORS
 11315 LOCKWOOD DRIVE SILVER SPRING, MARYLAND 20904 (301) 593-3400

DESIGNED	ROAD CONSTRUCTION PLANS EARLY RED COURT & LORING DRIVE	SCALE	AS SHOWN
DRAWN	VLS	DRAWING	1 OF 4
CHECKED	KIW	JOB NO.	83-076
DATE	VLS	FILE NO.	83-076-D

FOR: ORCHARD ASSOCIATES
 P.O. Box 312
 Columbia, Maryland 21044

STREET TREE SCHEDULE

KEY	DESCRIPTION	SIZE QUANT.	ROOT
OG	ACER RUBRUM OCTOBER GLORY	2 1/2" DIA	23 1/2 B
	OCTOBER GLORY MAPLE	MIN	
GA	FRAXINUS P. LANCEOLATA	2 1/2" DIA	10 1/2 B
	SEEDLESS GREEN ASH	MIN	

NOTES:
 * PLANTING TO COMPLY WITH L.C.A.M.W. LANDSCAPE SPECIFICATIONS
 * CONTRACTOR TO VERIFY UNDERGROUND UTILITIES BEFORE DIGGING
 * LOCATION OF TREES MAY VARY SLIGHTLY TO ACCOMMODATE FIELD CONDITIONS
 * STREET TREE PLANTING TO COMPLY WITH SECTION 16.131 OF THE HOWARD COUNTY SUBDIVISION REGULATIONS

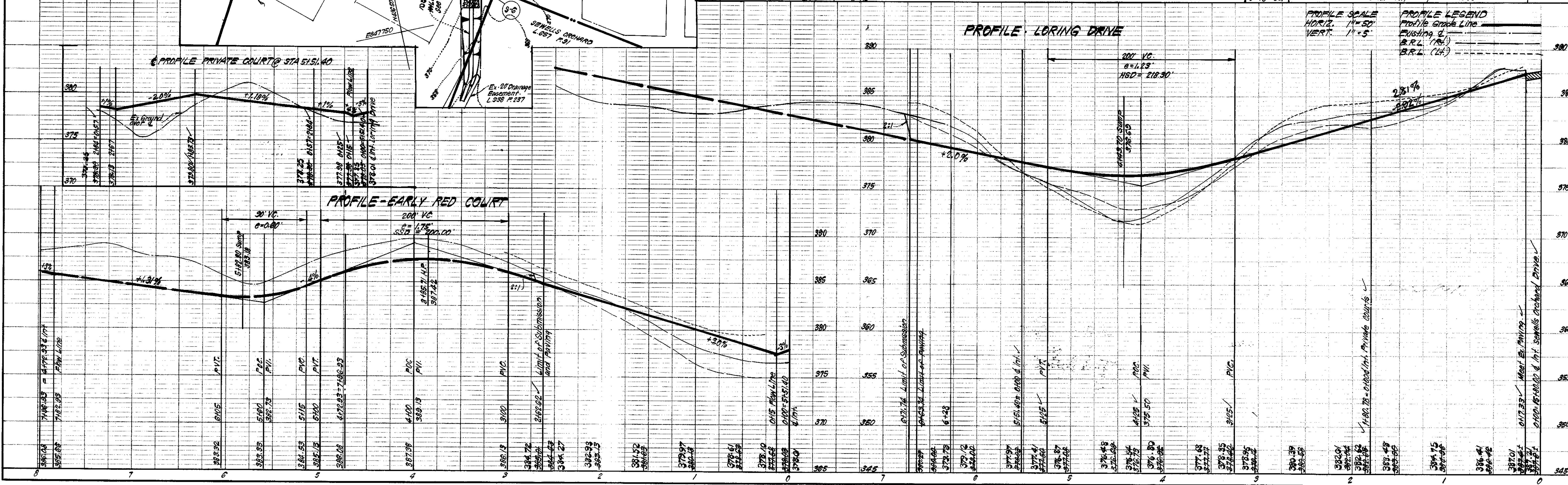

#850

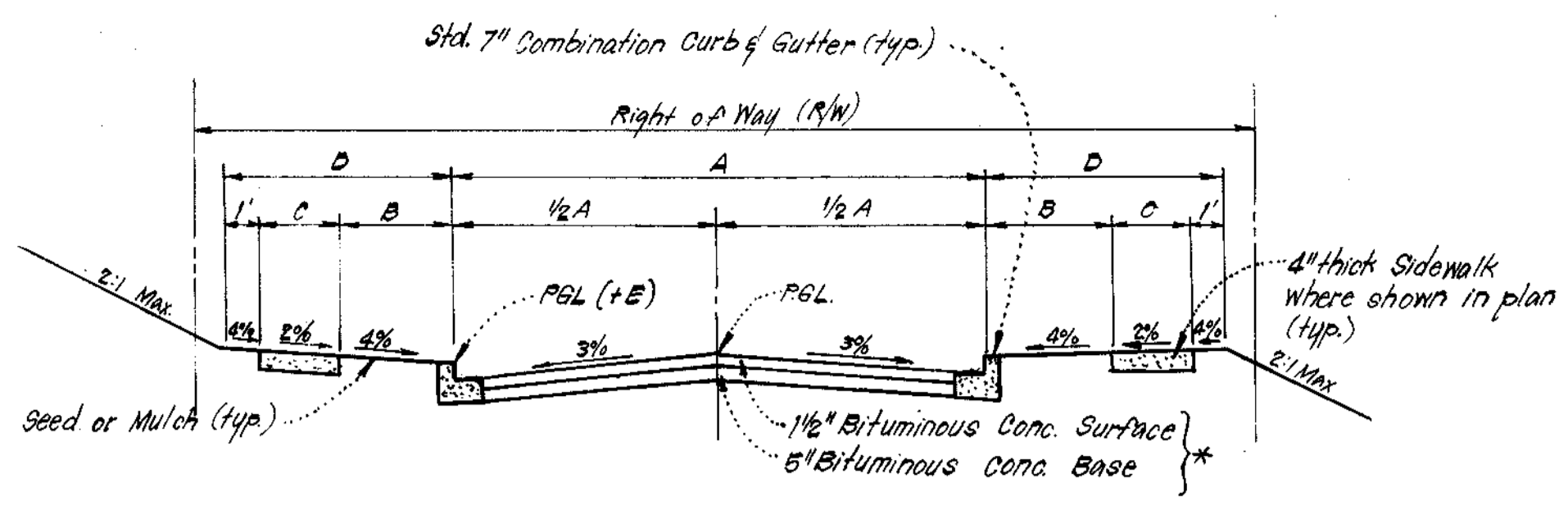

TYPICAL PAVING SECTION - PUBLIC ROADS
NO SCALE

STREET NAME & STATION	TYPE OF TRAFFIC	A	B	C	D	R/W	ZONING	DESIGN SPEED	E
Loring Drive 0+00 to 0+71.74	Local	30'	4'	4'	9'	50'	RSC	30	+10
Early Red Court 0+00 to 0+75.70	Cul-de-Sac	28'	4'	4'	9'	50'	RSC	30	+14

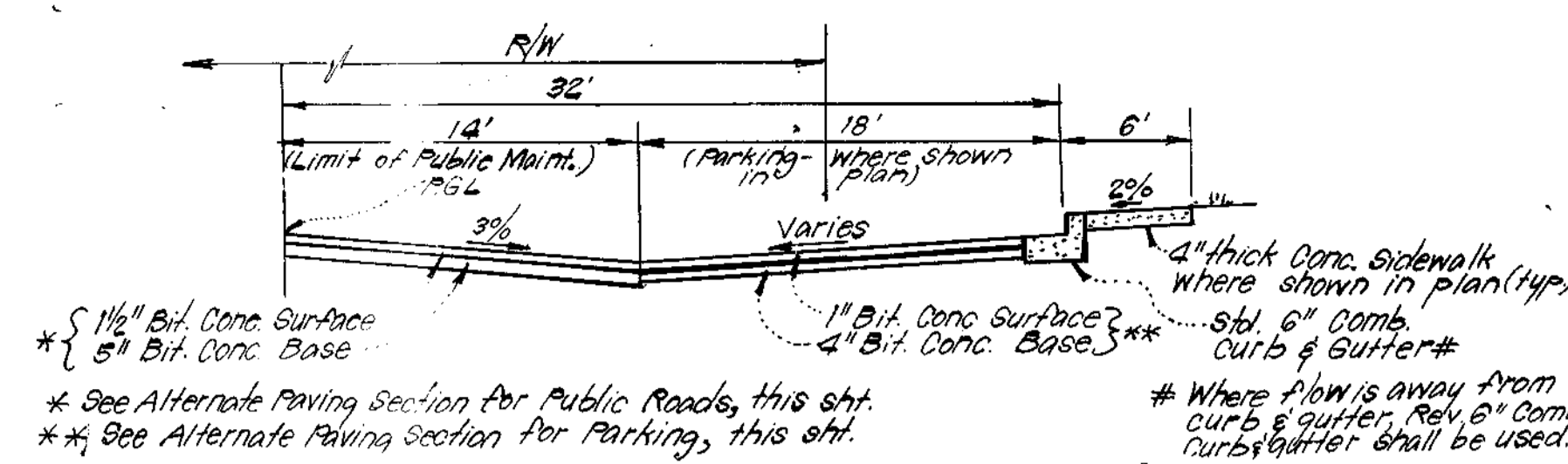

TYPICAL HALF SECTION - PARKING ADJACENT TO PUBLIC ROADS
NO SCALE

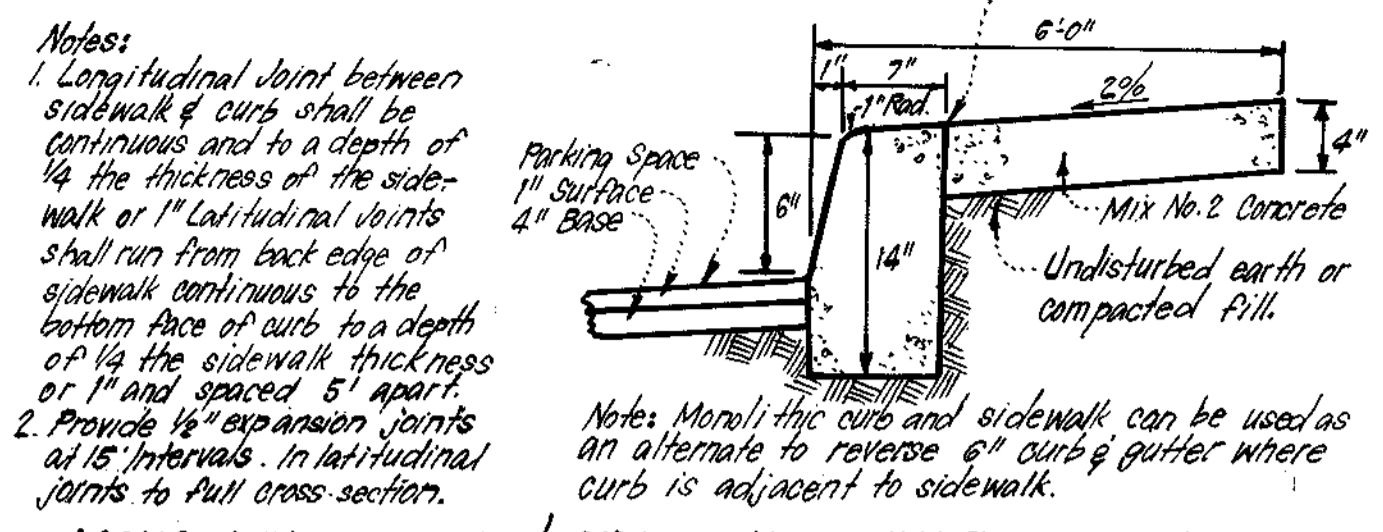

MONOLITHIC CURB & SIDEWALK - PRIVATE PARKING AREA
NO SCALE

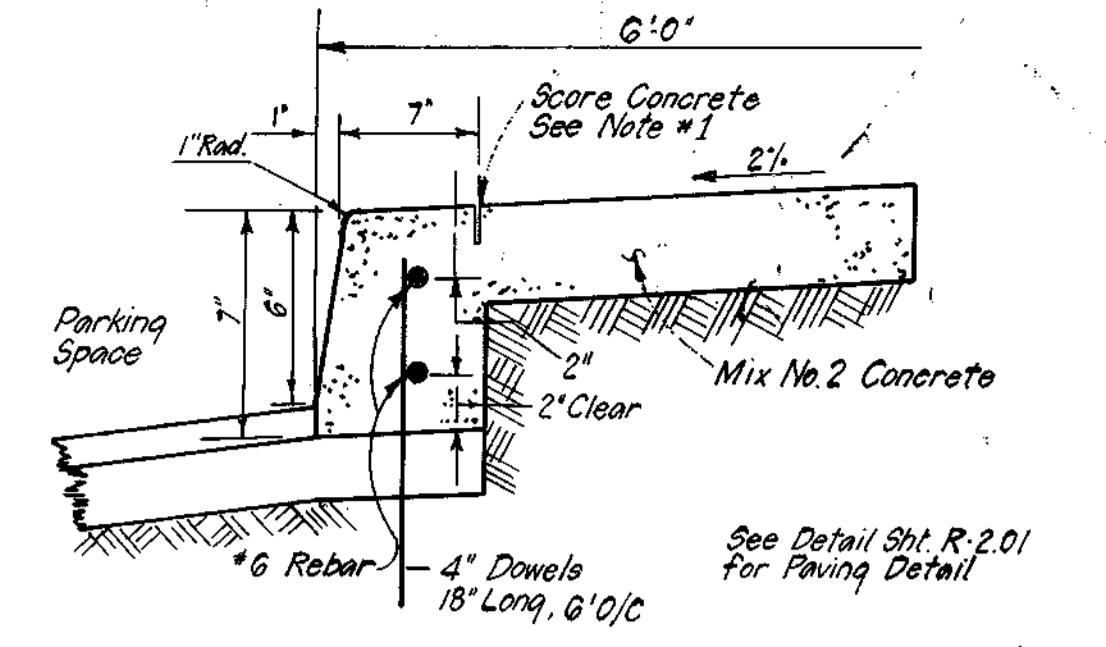

ALTERNATE SECTION
NO SCALE

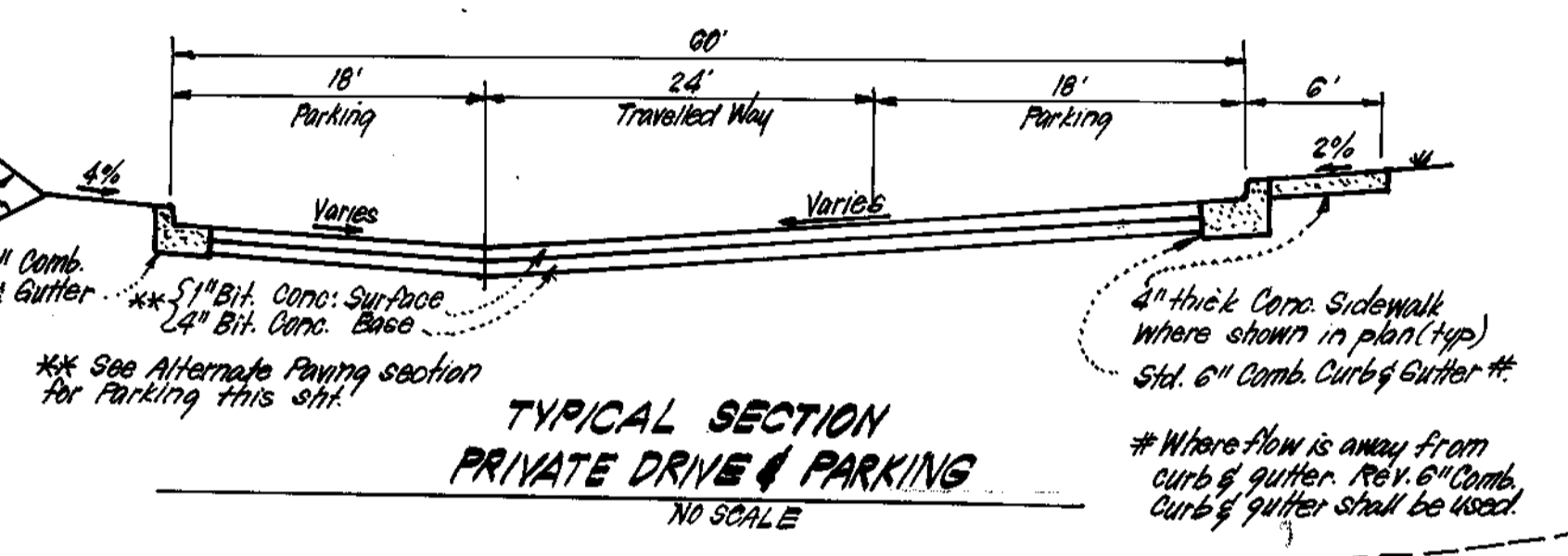

TYPICAL SECTION PRIVATE DRIVE & PARKING
NO SCALE

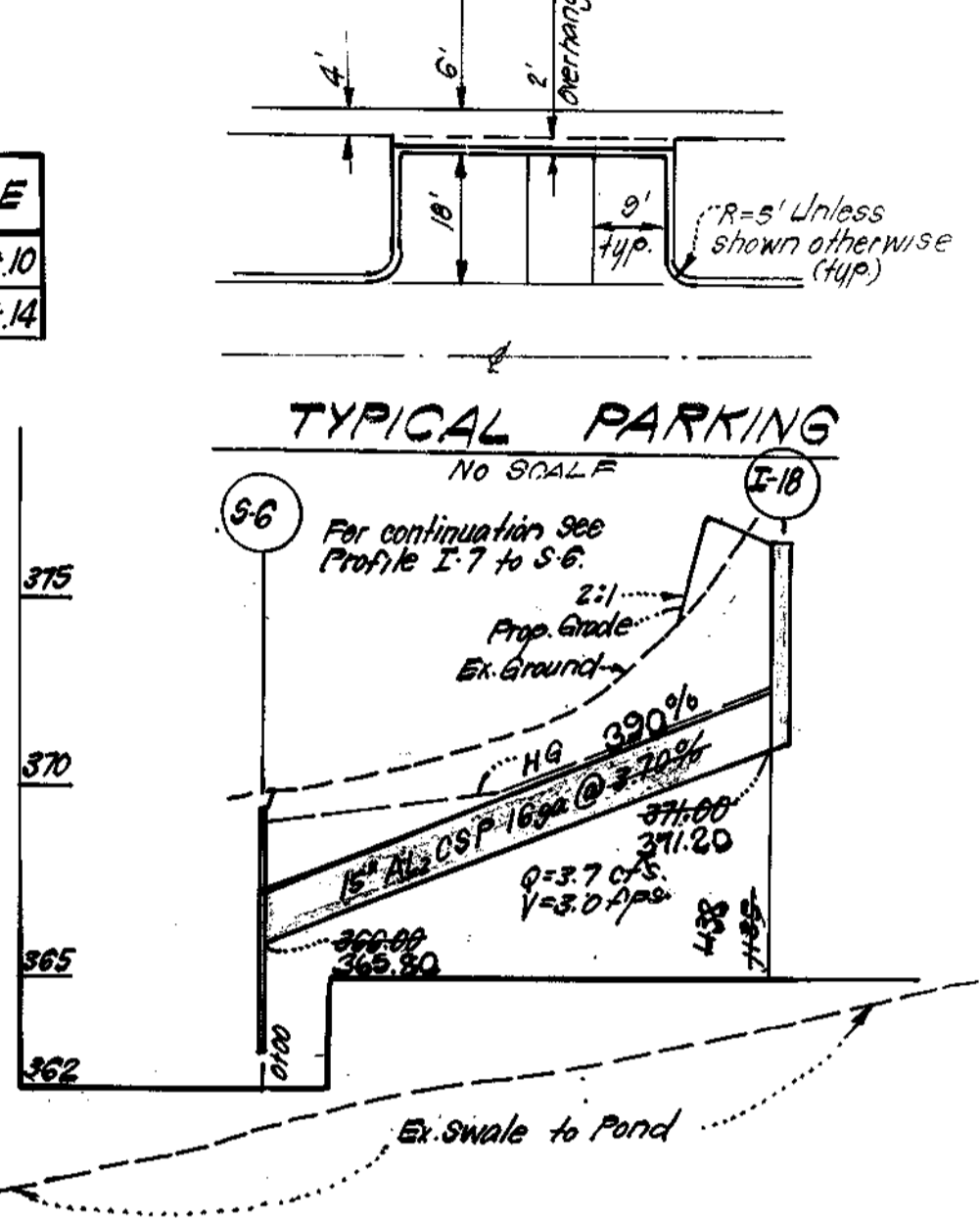

TYPICAL PARKING
NO SCALE

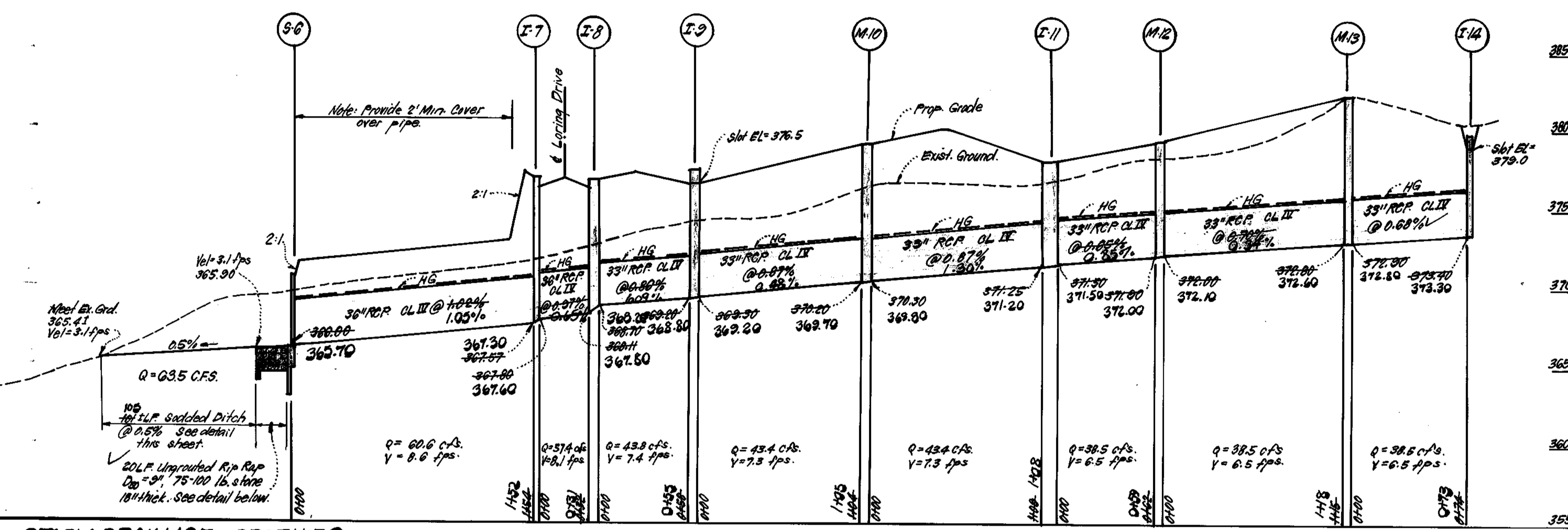

STORM DRAINAGE PROFILES
NO SCALE

Material	Thickness	Material	Thickness
Bituminous Conc. Surface	1/2"	Bituminous Conc. Surface	1"
Bituminous Conc. Base	2 1/2"	Bituminous Conc. Base	2"
Prime	1"	Prime	1"
8" Crusher Run Base (Placed in 2 Courses)	8"	5" Crusher Run Base Course	5"
or		4" Dense Graded Stabilized Aggregate Base Course	4"
6" Dense Graded Stabilized Aggregate Base Course	6"		

ALTERNATE PAVING SECTION FOR PUBLIC ROADS
NO SCALE

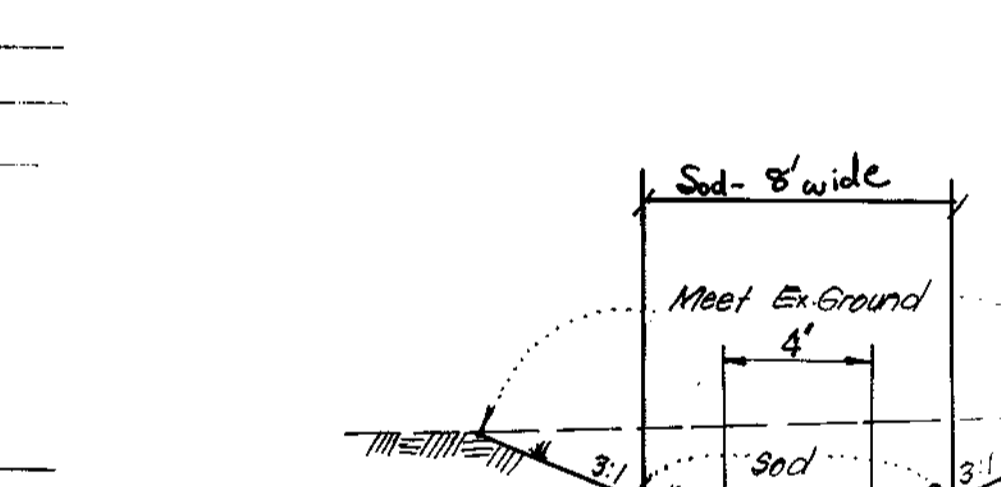

SODDED DITCH DETAIL
NO SCALE

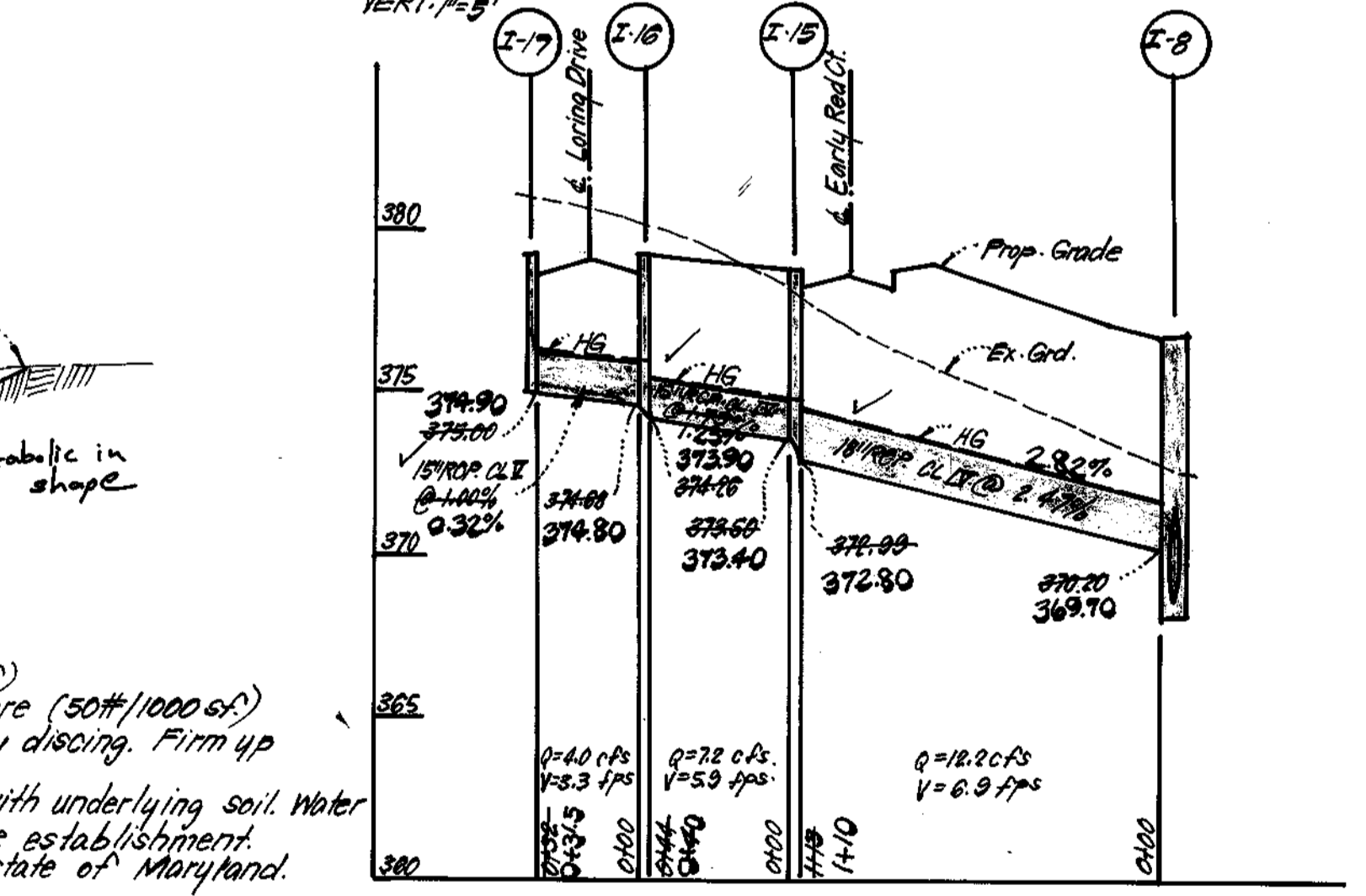

STORM DRAINAGE PROFILES
NO SCALE

No.	TYPE	INV. IN	INV. OUT	TOP ELEVATION	REMARKS	LOCATION
9-6	A-Endwall	365.70	366.00	366.00	1/2" G.C. Sid. SD/5.11	360 Pkwy
9-7	A-10 Inlet	367.60	367.90	367.90	W=2'-6"	4 Inlet Sta 4+43.70 15' LT
9-8	A-10 Inlet	368.80	369.10	369.10	W=4'-6"	4 Inlet Sta 4+43.70 15' RT
9-9	D Inlet	369.20	369.50	369.50	SD/4.11	48" Dia. See Plan
10-10	Brick Manhole	370.00	370.30	370.30	6'-5.02	5'-0" Rd. "
10-11	A-10 Inlet	371.50	371.80	371.80	SD/4.02	W=4'-0" "
10-12	Brick Manhole	372.10	372.40	372.40	6'-5.02	5'-0" Rd. "
10-13	Brick Manhole	372.80	373.10	373.10	6'-5.02	5'-0" Rd. "
10-14	D Inlet	373.40	373.70	373.70	SD/4.11	48" Dia. "
10-15	A-10 Inlet w/Deflectors	374.00	374.30	374.30	SD/4.02	W=2'-6" 4 Inlet Sta 4+43.70 15' LT
10-16	A-10 Inlet	374.80	375.10	375.10	SD/4.02	W=2'-6" 4 Inlet Sta 4+43.70 15' RT
10-17	A-10 Inlet	375.60	375.90	375.90	SD/4.02	W=2'-6" 4 Inlet Sta 4+43.70 15' LT
10-18	A-5 Inlet	376.40	376.70	376.70	SD/3.01	W=2'-6" See Plan
10-19	Special	377.20	377.50	377.50	See Detail Sta 9	" "
10-20	Manhole End Section	378.00	378.30	378.30	1/2" G.C. Sid. SD/5.61	48" Dia. "

STRUCTURE SCHEDULE
NO SCALE

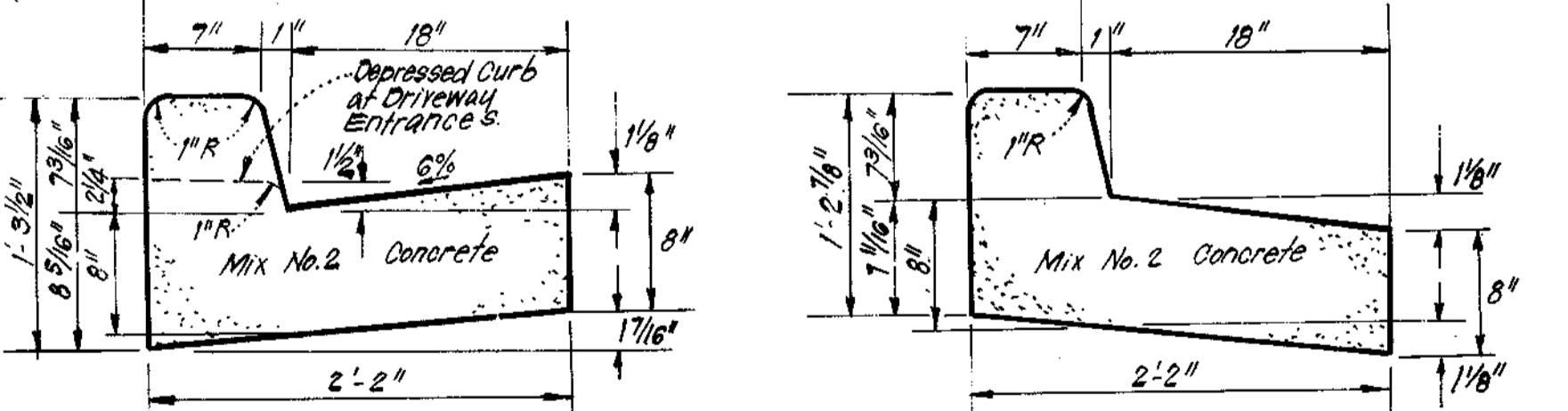

STANDARD 7" COMBINATION CURB & GUTTER
NO SCALE

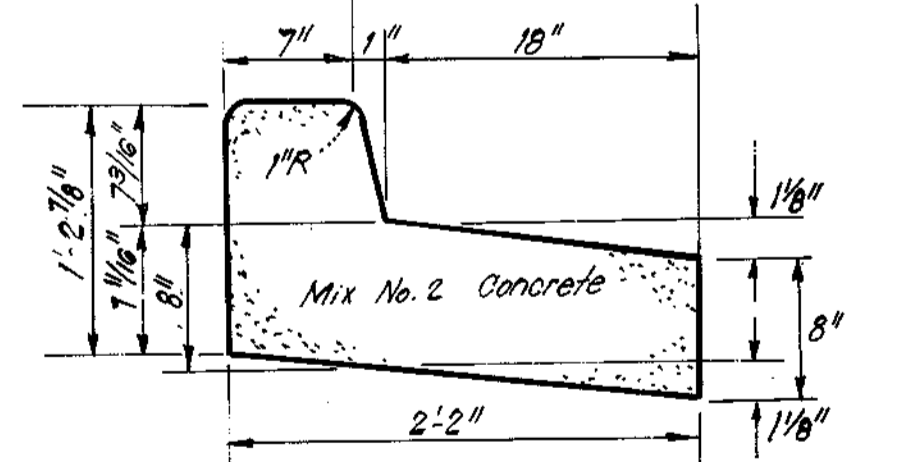

REVERSE 7" COMBINATION CURB & GUTTER
NO SCALE

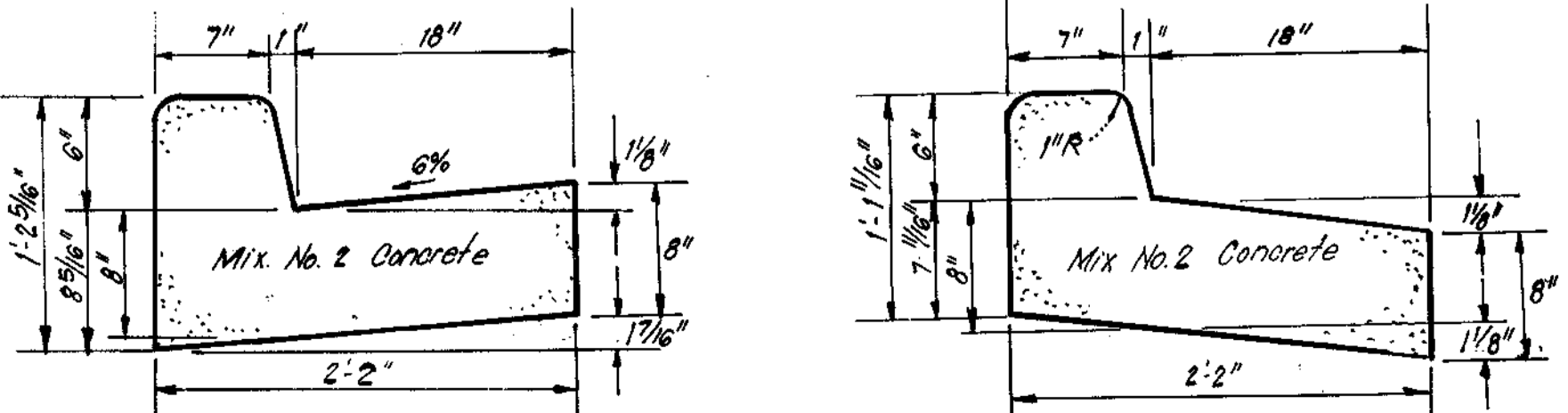

STANDARD 6" COMBINATION CURB & GUTTER
NO SCALE

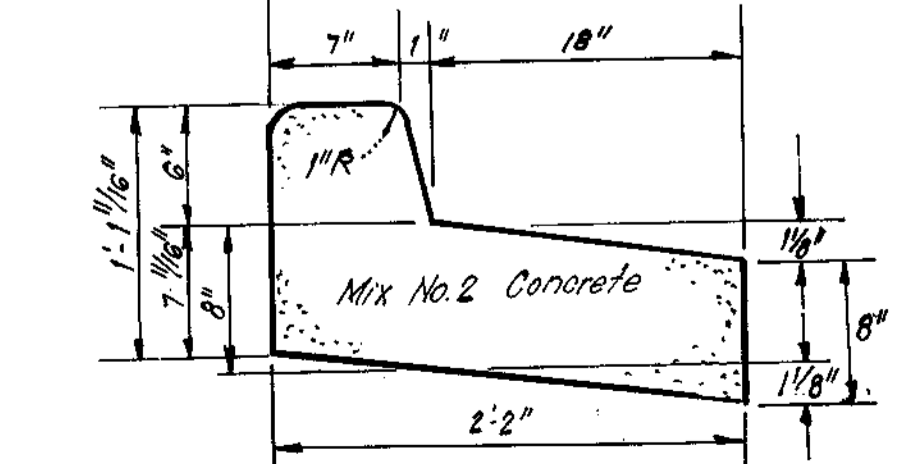

REVERSE 6" COMBINATION CURB & GUTTER
NO SCALE

- GENERAL SODDING NOTES:
- Apply 10-10-10 Fertilizer @ 1000#/acre (25#/1000sf)
 - Apply Ground Agricultural Limestone @ 2000#/acre (50#/1000sf)
 - Incorporate both Lime and Fertilizer into soil by disking. Firm up after incorporation.
 - Lay sod to a tight fit. Roll to insure contact with underlying soil. Water as necessary for 1st 2 weeks, in summer, to ensure establishment.
 - All sod to be used must be certified by the state of Maryland.
 - Sod to be pegged and stapled.

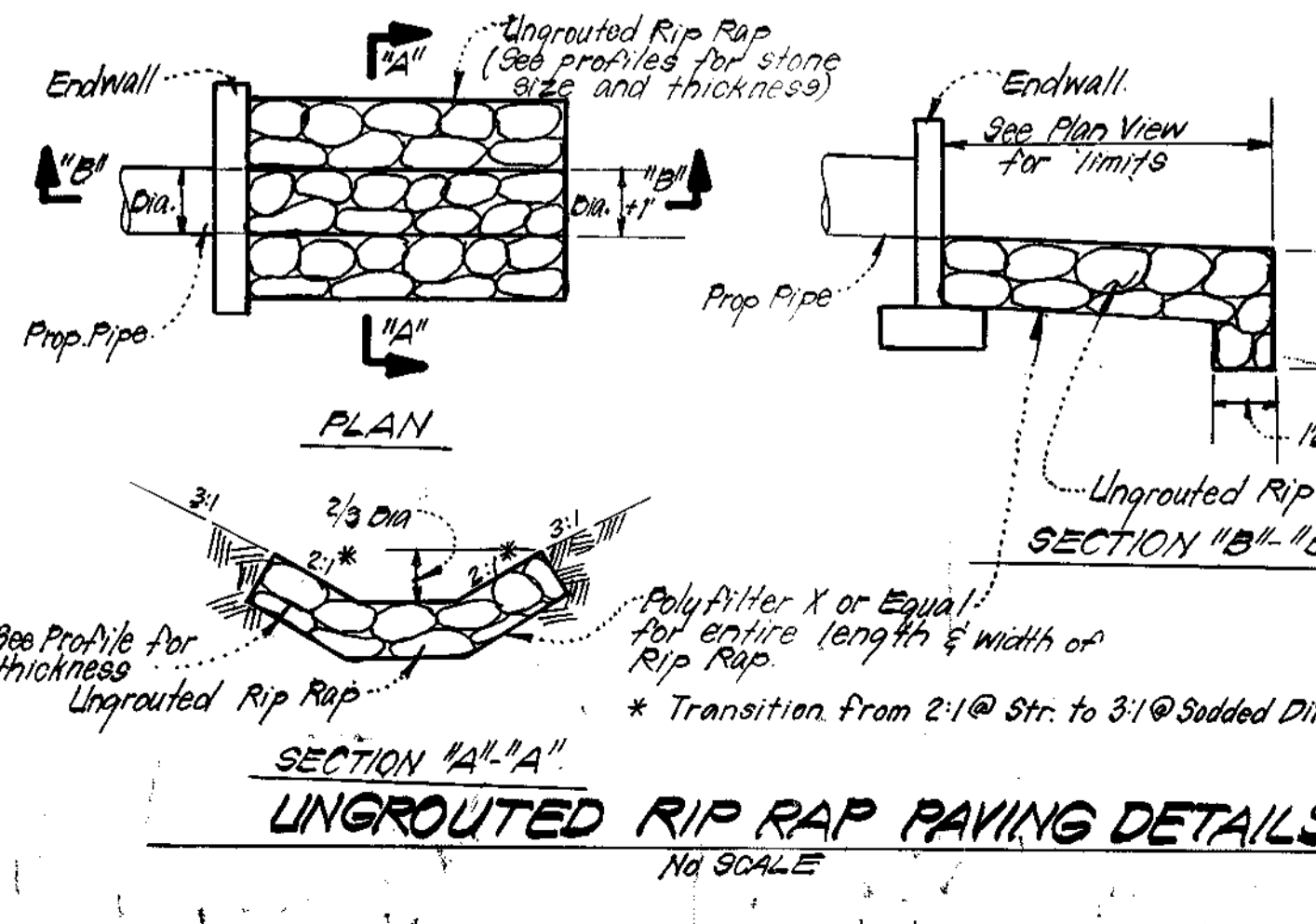

UNGROUTED RIP RAP PAVING DETAILS
NO SCALE

AS-BUILD SURVEY CERTIFIED BY
G. NELSON CLARK REG. P.E.
NO. 7139 ON JUNE 19, 1984

Reviewed for: HOWARD COUNTY S.C.D.
Name: G. NELSON CLARK
Date: 8-16-84
Signature: G. Nelson Clark
U.S. Soil Conservation Service

DEVELOPER'S/BUILDER'S CERTIFICATE
"I/We certify that all development and construction will be done according to this plan of development and plan for erosion and sediment control and that all responsible personnel involved in the construction project will have a Certificate of Attendance at a Dept. of Natural Resources Approved Training Program for the Control of Sediment and Erosion before beginning the project. I also authorize periodic on-site inspection by the Howard Soil Conservation District or their authorized agents as are deemed necessary."
Signature: G. Nelson Clark
Date: 6/20/84

ENGINEER'S CERTIFICATE
I hereby certify that this plan for Erosion and Sediment Control represents a practical and workable plan based on my personal knowledge of the site conditions and that it was prepared in accordance with the requirements of the Howard Soil Conservation District.
Signature: G. Nelson Clark
Date: 6/10/84

SIZE	TYPE	LENGTH
15"	ALGOSP 16page	135 LF
15"	RCP CL I	32 LF
15"	RCP CL II	42 LF
15"	RCP CL III	113 LF
36"	RCP CL IV	522 LF
36"	RCP CL V	122 LF
48"	BCCM 16page	22 LF

PIPE SCHEDULE
NO SCALE

APPROVED: Department of Public Works
 Approved: [Signature] 8-17-84
 Chief, Bureau of Engineering
 Approved: Howard County Office of Planning and Zoning
 Approved: [Signature] 8-16-84
 Chief, Division of Land Development & Zoning Administration

CLARK · FINEFROCK & SACKETT
 ENGINEERS · PLANNERS · SURVEYORS
 11314 LOCKWOOD DRIVE · SILVER SPRING, MARYLAND 20904 (301) 993-3400

DESIGNED: [Signature] SCALE: AS SHOWN
 DRAWN: [Signature] DRAWING NO.: 204
 CHECKED: [Signature] JOB NO.: 83-076
 DATE: 6-18-84 FILE NO.: 83-076

SECTION 3 AREA 1
 6TH ELECTION DISTRICT
 HOWARD COUNTY, MARYLAND
 FOR ORCHARD ASSOCIATES
 P.O. Box 309
 Columbia, Md 21044

LEGEND:

1. Contour Interval 2 Ft.
2. Existing Contour
3. Direction of Drainage
4. Proposed Storm Drain
5. Existing Storm Drain

15.8 Acre Total
Draining to E-14
See S.D. Comps.

CONSTRUCTION SEQUENCE:

1. Install Stabilized Construction Entrance.
2. Construct SWM Pond / Sediment Basin and Brick Shut 14" Dia. Orifice and immediately stabilize pond and disturbed areas on pond slopes.
3. Clear and Rough Grade Site.
4. Construct remainder of storm drainage.
5. Construct Utilities.
6. Fine grade and construct Paving, Sidewalks, etc.
7. Stabilize all other disturbed areas onsite in accordance with stds. and specs.
8. Flush out storm drainage system.
9. Upon approval of sediment control inspector, remove sediment & erosion control measures.

*** Special Notes for Modification of Existing Wet Pond.**

- A. Drain existing Pond.
- B. Remove existing spillway and construct prop. spillway.
- C. Regrade pond as shown in plan and extend and raise top of dam as shown.
- D. Immediately stabilize all regraded areas above prop. normal pool in accordance with stds. and specs and downstream embankment slope.

* As per COMAR 08.05.01.06 -- "Following initial soil disturbance or redistribution, permanent or temporary stabilization shall be completed within: (a) Seven calendar days as to the surface of all perimeter controls, dikes, swales, ditches, perimeter slopes, and all slopes greater than 3 horizontal to 1 vertical (3:1) and (b) Fourteen days as to all other disturbed or graded areas on the project site."

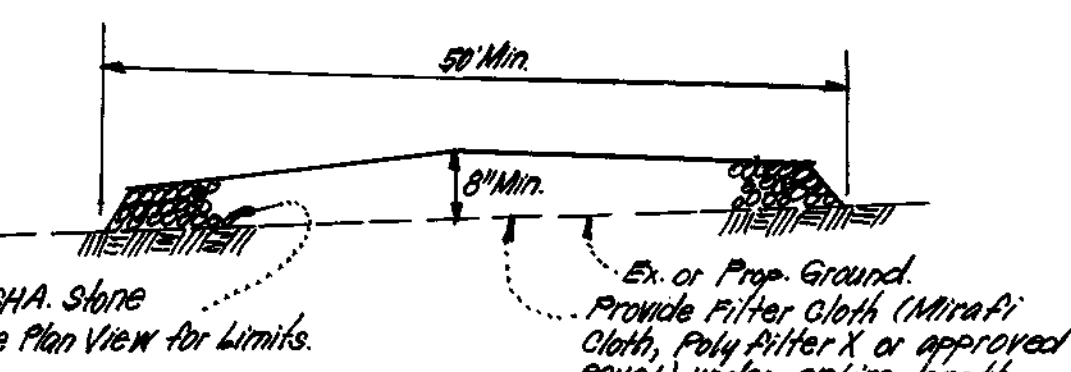
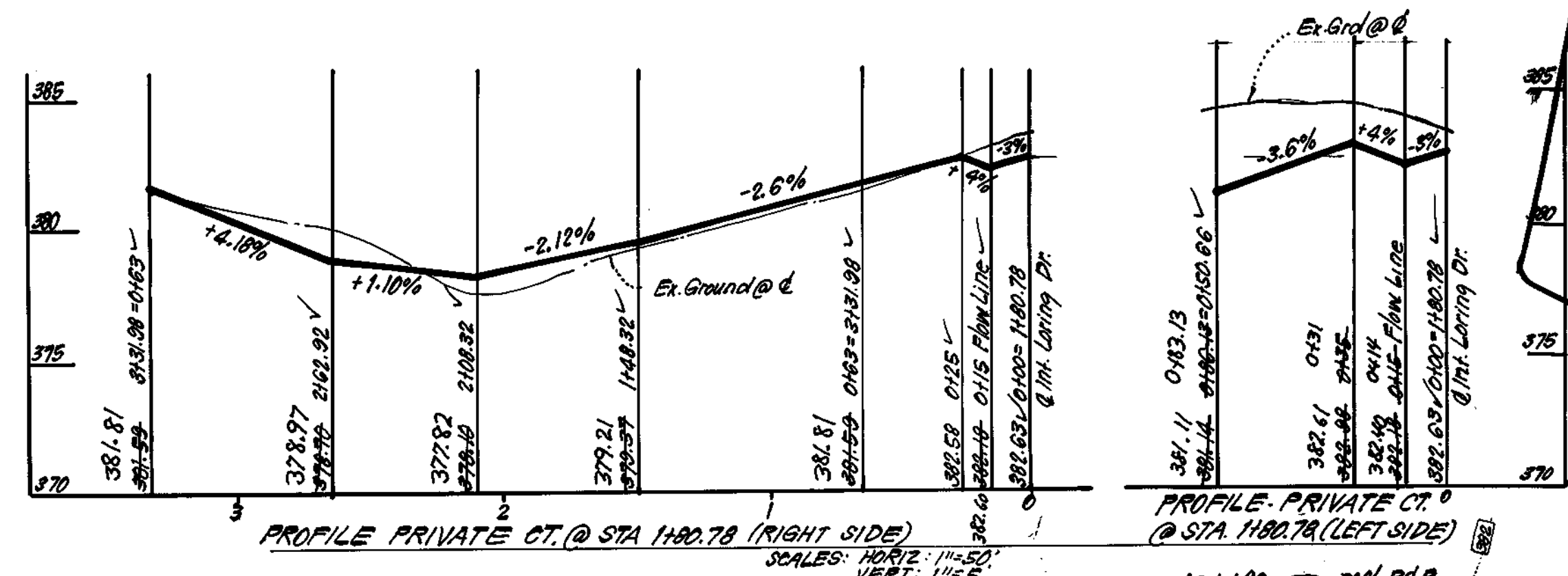

STABILIZED CONSTRUCTION ENTRANCE

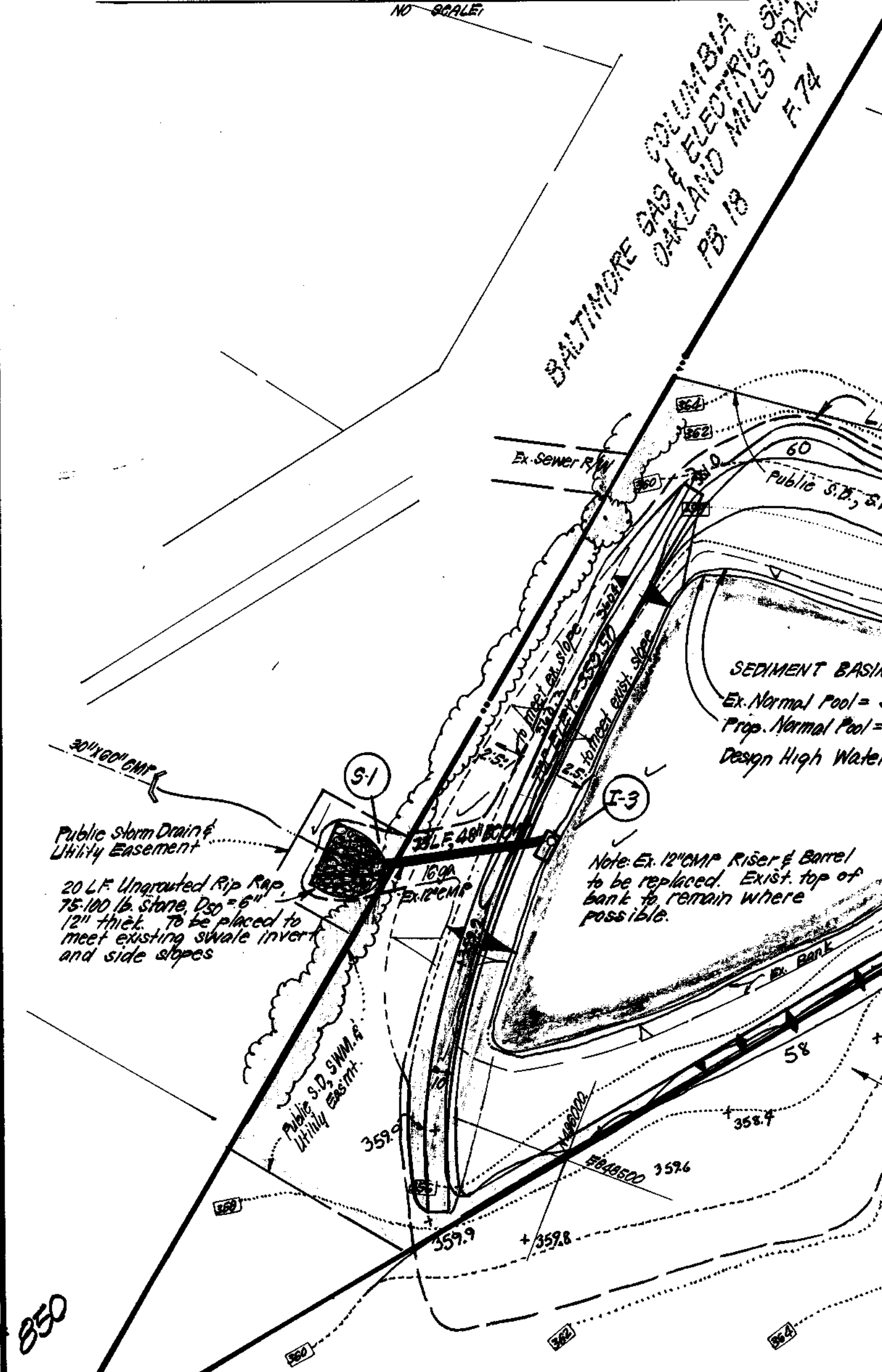

For Sediment & Erosion Control
Brick Shut 14" Dia. Orifice

Brick Shut Has been removed

44.1 Acre Total
Drain to SWM Pond
See S.W.M. Computations.

SEDIMENT BASIN & SWM POND
Ex. Normal Pool = 354.2
Prop. Normal Pool = 353.0
Design High Water = 358.38

Note: Ex. 12" CMP Riser & Barrel to be replaced. Exist. top of bank to remain where possible.

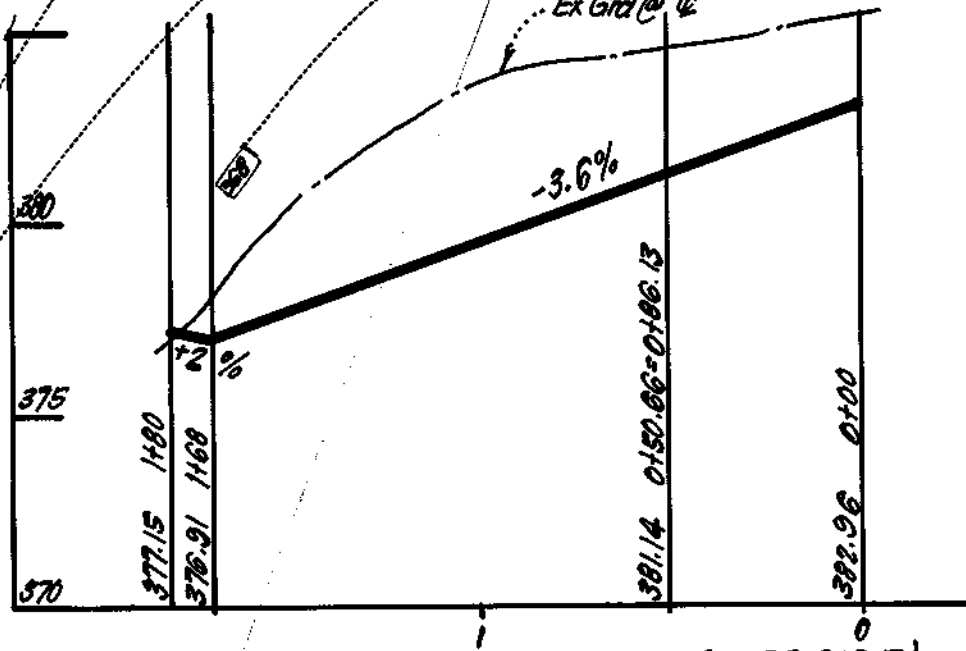

PROFILE - PRIVATE CT. @ STA 1180.78 (LEFT SIDE)
SCALE: HORIZ. 1"=50', VERT. 1"=5'

These plans have been reviewed for the Howard Soil Conservation District and meet the technical requirements for small pond construction, soil erosion and sediment control.

Approved: *[Signature]* 8-16-84
U.S. Soil Conservation Service Date

Approved: *[Signature]* 8-16-84
Howard E. Zickler Date

Plan Number



ENGINEER'S CERTIFICATE

"I certify that this plan for pond construction, erosion, and sediment control represents a practical and workable plan based on my personal knowledge of the site conditions. This plan was prepared in accordance with the requirements of the Howard Soil Conservation District. I have notified the developer that he must provide the Howard Soil Conservation District with a red-lined 'as built' of the pond within 30 days of completion."

Approved: *[Signature]* 6-17-84
Signature of Engineer Date

AS-BUILD SURVEY CERTIFIED BY
G. NELSON CLARK REG.-P.E.
NO. 7139 ON JUNE 19, 1984

DEVELOPER'S CERTIFICATE

"I certify that all development and/or construction will be done according to these plans of development, pond construction and erosion and sediment control. I also authorize periodic on-site inspection by the Howard Soil Conservation District or their authorized agents, as are deemed necessary. Deviation from this plan will not be made unless authorized by The Howard Soil Conservation District. I will provide the Howard Soil Conservation District with a red-lined 'as built' of the pond within 30 days of completion."

Approved: *[Signature]* 6/20/84
Signature of Developer Date

APPROVED: DEPARTMENT OF PUBLIC WORKS:

[Signature] 8-17-84
Chief, Bureau of Engineering Date
APPROVED: HOWARD COUNTY OFFICE OF PLANNING AND ZONING
[Signature] 8-16-84
Chief, Division of Land Development & Zoning Administration Date

CLARK FINEFROCK & SACKETT ENGINEERS PLANNERS SURVEYORS 11315 LOCKWOOD DRIVE SILVER SPRING, MARYLAND 20904 (301) 593-3400		
DESIGNED	VLS	SCALE
DRAWN	KIW	AS SHOWN
CHECKED	VLS	DRAWING
DATE	6-18-84	JOB NO.
		83-076
		FILE NO.
		83-076 D

6/19/84 AS-BUILT

STORM WATER MANAGEMENT POND NOTES

SEDIMENT & EROSION CONTROL NOTES

I. SITE PREPARATION:

- A. Areas designated for borrow areas, embankment, and structural works shall be cleared, grubbed and stripped of topsoil. All trees, vegetation, roots and other objectionable material shall be removed. Channel banks and sharp breaks shall be sloped no steeper than 1:1.
- B. Areas to be covered by pond or reservoir will be cleared of all trees, brush, logs, fences, rubbish and other objectionable material unless otherwise designated on the plans. Trees, brush, and stumps shall be cut approximately level with the ground surface.
- C. All cleared and grubbed material shall be disposed of outside and below the limits of the dam and reservoir as directed by the owner or his representative. When specified, a sufficient quantity of topsoil will be stockpiled in a suitable location for use on the embankment and other designated areas.

II. EARTH FILL:

- A. MATERIAL: The fill material shall be taken from approved designated borrow area or areas. It shall be free of roots, stumps, wood, rubbish, oversized stones, frozen or other objectionable materials. The embankment shall be constructed to an elevation which provides for anticipated settlement to the design elevation. The fill height all along the length of the embankment shall be increased above the design elevation (including freeboard) as shown on the plans.
- B. PLACEMENT: Areas on which fill is to be placed shall be scarified prior to placement of fill. Fill materials shall be placed in 8-inch maximum thickness (before compaction) layers which are to be continuous over the entire length of the fill. The most porous borrow material shall be placed in the downstream portions of the embankment.
- C. COMPACTION: The movement of the hauling and spreading equipment over the fill shall be controlled so that the entire surface of each lift shall be traversed by not less than one tread track of the equipment or compaction shall be achieved by a minimum of four complete passes of a sheepsfoot, rubber tired, or vibratory roller. Fill material shall contain sufficient moisture so that the required degree of compaction can be obtained with the equipment used. Where a minimum required density is specified, each layer of fill shall be compacted as necessary to obtain that density and is to be certified by the Engineer.
- D. CUTOFF TRENCH: Where specified, a cutoff trench shall be excavated along or parallel to the centerline of the embankment as shown on the plans. The bottom width of the trench shall be as shown on the drawings, with the minimum width being four feet. The depth shall be at least four feet or as shown on the plans. The side slopes of the trench shall be 1 to 1 or flatter. The backfill material for the cutoff trench shall be the most impervious material available and shall be compacted with equipment or rollers to assure maximum density and minimum permeability.

III. STRUCTURAL BACKFILL:

Backfill material shall be of the type and quality conforming to that specified for the adjoining fill material. The fill shall be placed in horizontal layers not to exceed four inches in thickness and compacted by hand tampers or other compaction equipment. The material needs to fill completely all spaces under and adjacent to the pipe. At no time during the backfilling operation shall be driven equipment be allowed to operate closer than four feet, measured horizontally, to any part of the structure. Under no circumstances shall equipment be driven over any part of a concrete structure or pipe unless there is a compacted fill of twenty-four inches or greater over the structure or pipe.

IV. PIPE CONDUITS: All pipes shall be circular in cross-section.

A. CORRUGATED METAL PIPE:

- 1. MATERIALS: (Steel Pipe) - This pipe and its appurtenances shall be galvanized and fully bituminous coated and shall conform to the requirements of AASHTO Specifications M-190 Type A with watertight coupling bands. Any bituminous coating damaged or otherwise removed shall be replaced with cold applied bituminous coating compound. Steel pipes with polymeric coatings shall have a minimum coating thickness of 0.01 inch (10 mil.) on both sides of the pipe. The following coatings are commercially available: Nexon, Plasti-Cote, Blac-Klad, and Beth-Cu-Loy Coated corrugated steel pipe shall meet the requirements of AASHTO M-245 and M-246.
- 2. MATERIALS (Aluminum Steel Pipe) - This pipe and its appurtenances shall conform to the requirements of AASHTO Specification M-274-791 with watertight coupling bands or flanges.
- 3. MATERIALS (Aluminum Pipe) - This pipe and its appurtenances shall conform to the requirements of AASHTO Specification M-196 or M-211 with watertight coupling bands or flanges. Coupling bands, anti-seep collars, and sections etc. must be composed of the same material as the pipe. Metals must be insulated from dissimilar materials with use of rubber or plastic insulating materials at least 24 mils in thickness. Aluminum surfaces that are to be in contact with concrete shall be painted with one coat of Zinc Chromate Primer. Hot dip galvanized bolts may be used for connections. The pH of the surrounding soils shall be less than 9 and greater than 4.

- 4. CONNECTIONS: All connections with pipes must be completely watertight. The drain pipe or barrel connection to the riser shall be welded all around when the pipe and riser are metal. Watertight coupling bands or flanges shall be used at all joints. Anti-seep collars shall be connected to the pipe in such a manner as to be completely watertight. Dip bands are not considered to be watertight.
- 5. BEDDING: The pipe shall be firmly and uniformly bedded throughout its entire length. Where rock or soft, spongy or other unstable soil is encountered, all such material shall be removed and replaced with suitable earth compacted to provide adequate support.
- 6. LAYING PIPE: The pipe shall be placed with inside circumferential laps pointing downstream and with the longitudinal laps at the sides.
- 7. Backfilling shall conform to structural backfill as shown above.
- 8. Other details (anti-seep collars, valves, etc.) shall be as shown on the drawings.

B. REINFORCED CONCRETE PIPE

- 1. MATERIALS: Reinforced concrete pipe shall have a rubber gasket joint and shall equal or exceed ASTM Specification C-361. An approved equivalent is AWWA Specification C-301.
- 2. BEDDING: All reinforced concrete pipe conduits shall be laid in a concrete bedding for their entire length. This bedding shall consist of hot slump concrete placed under the pipe and up the sides of the pipe at least 10% of its outside diameter with a minimum thickness of 3", or as shown on the drawings.
- 3. LAYING PIPE: Bell and spigot pipe shall be placed with the bell end upstream. Joints shall be made in accordance with recommendations of the manufacturer of the material. After the joints are sealed for the entire line, the bedding shall be placed so that all spaces under the pipe are filled. Care shall be exercised to prevent any deviation from the original line and grade of the pipe.
- 4. Backfilling shall conform to structural backfill as shown above.
- 5. Other details (anti-seep collars, valves, etc.) shall be shown on the drawings.

C. For pipes of other materials, specific specifications shall be shown on the drawings.

V. CONCRETE

A. MATERIALS

- 1. CEMENT - Normal Portland cement shall conform to latest ASTM Specification C-150.
- 2. WATER - The water used in concrete shall be clean, free from oil, acid, alkali, scales, organic matter or other objectionable substances.
- 3. SAND - The sand used in concrete shall be clean, hard, strong, and durable, and shall be well graded with 100% passing a one quarter inch sieve. Limestone sand shall not be used.
- 4. COARSE AGGREGATE - The coarse aggregate shall be clean, hard, strong and durable, and free from clay and dirt. It shall be well graded with a maximum size of one-and-one-half (1 1/2) inches.
- 5. REINFORCING STEEL - The reinforcing steel shall be deformed bars of intermediate grade billet steel or rail steel conforming to ASTM Specification A-615.
- B. DESIGN MIX - The concrete shall be mixed in the following proportions, measured by weight. The water-cement ratio shall be 5/8 to 6 US Gals of water/34-pound bag of cement. The proportion of materials for the trial mix shall be 1:2-3/4. The combination of the aggregates may be adjusted to produce a plastic and workable mix that will not produce harshness in placing or honeycombing in the structure.
- C. MIXING - The concrete ingredients shall be mixed in batch mixers until the mixture is homogeneous and of uniform consistency. The mixing of each batch shall continue for not less than one and one-half minutes after all the ingredients, except the full amount of water, are in the mixer. The minimum mixing time is predicated on proper control of the speed of rotation of the mixture and of the introduction of the materials including water, into the mixer. Water shall be added, or to, during, and following the mixer-charging operations. Excessive overmixing requiring the addition of water to preserve concrete consistency shall not be permitted. Truck mixing will be allowed provided that the use of this method shall cause no violation of any applicable provisions of the specifications given here.
- D. FORMS - The forms shall have sufficient strength and rigidity to hold the concrete and to withstand the necessary pressure, tamping and vibration without deflection from the prescribed lines. They shall be mortar-tight and constructed so they can be removed without hammering or prying against the concrete. The inside of the forms will be oiled with a non staining mineral oil or thoroughly wetted before concrete is placed. Forms may be removed 24 hours after the placement of concrete. All wire ties and other devices used shall be recessed from the surface of the concrete.
- E. REINFORCING STEEL - All reinforcing material shall be free of dirt, rust, scale, oil, paint or any other coatings. The steel shall be accurately placed and securely tied and blocked into position so that no movement of the steel will occur during placement of concrete.
- F. CONSOLIDATION - Concrete shall be consolidated with internal type mechanical vibrators. Vibration shall be supplemented by spading and hand tamping as necessary to insure smooth and dense concrete along form surfaces, in corners, and around embedded items.
- G. FINISHING - Defective concrete, honey combed areas, voids left by removal of the rebar, ridges on all concrete surfaces permanently exposed to view or exposed to water on the finished structure, shall be repaired immediately after the removal of forms. All voids shall be reamed and completely filled with dry patching mortar.
- H. PROTECTION AND CURING - Exposed surfaces of concrete shall be protected from the direct rays of the sun for at least three (3) days. All concrete shall be kept continuously moist for at least ten (10) days after being placed. Moisture may be applied by spraying or sprinkling as necessary to prevent the concrete from drying. Concrete shall not be exposed to freezing during the curing period. Curing compound may also be used.
- I. PLACING TEMPERATURE - Concrete may not be placed at temperature below 37F with the temperature falling, or 34F with the temperature rising.

VI. STABILIZATION

All borrow areas shall be graded to provide drainage and left in a slightly condition. All exposed surfaces of the embankment, spillway, spoil and borrow areas, and berms shall be stabilized by seeding, liming, fertilizing, and mulching (if required) in accordance with the vegetative treatment specifications or as shown on the accompanying drawings.

VII. EROSION AND SEDIMENT CONTROL

Construction operations will be carried out in such a manner that erosion will be controlled and water and air pollution minimized. State and local laws concerning pollution abatement will be followed. Construction plans shall detail erosion and sediment control measures to be employed during the construction process.

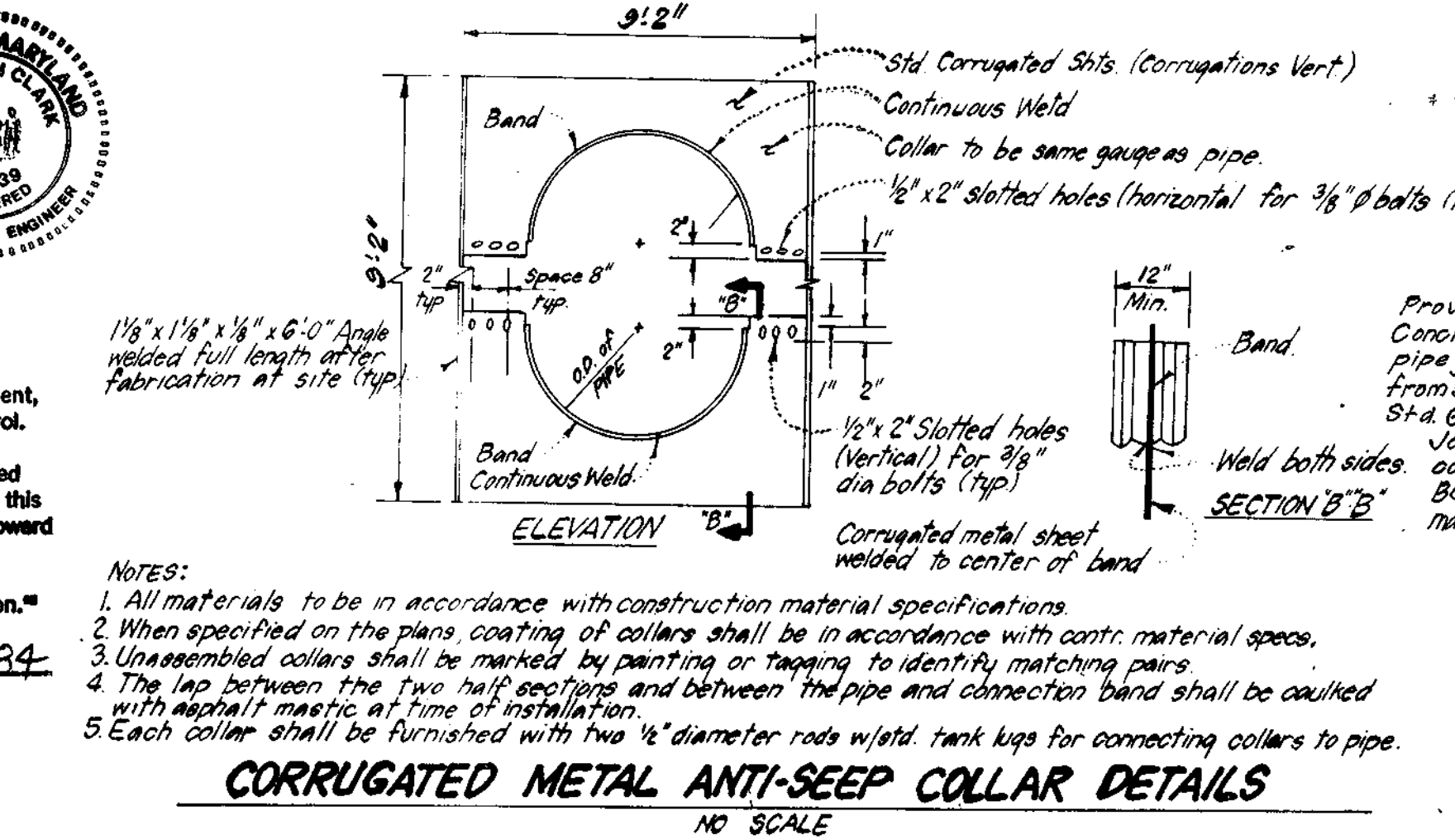
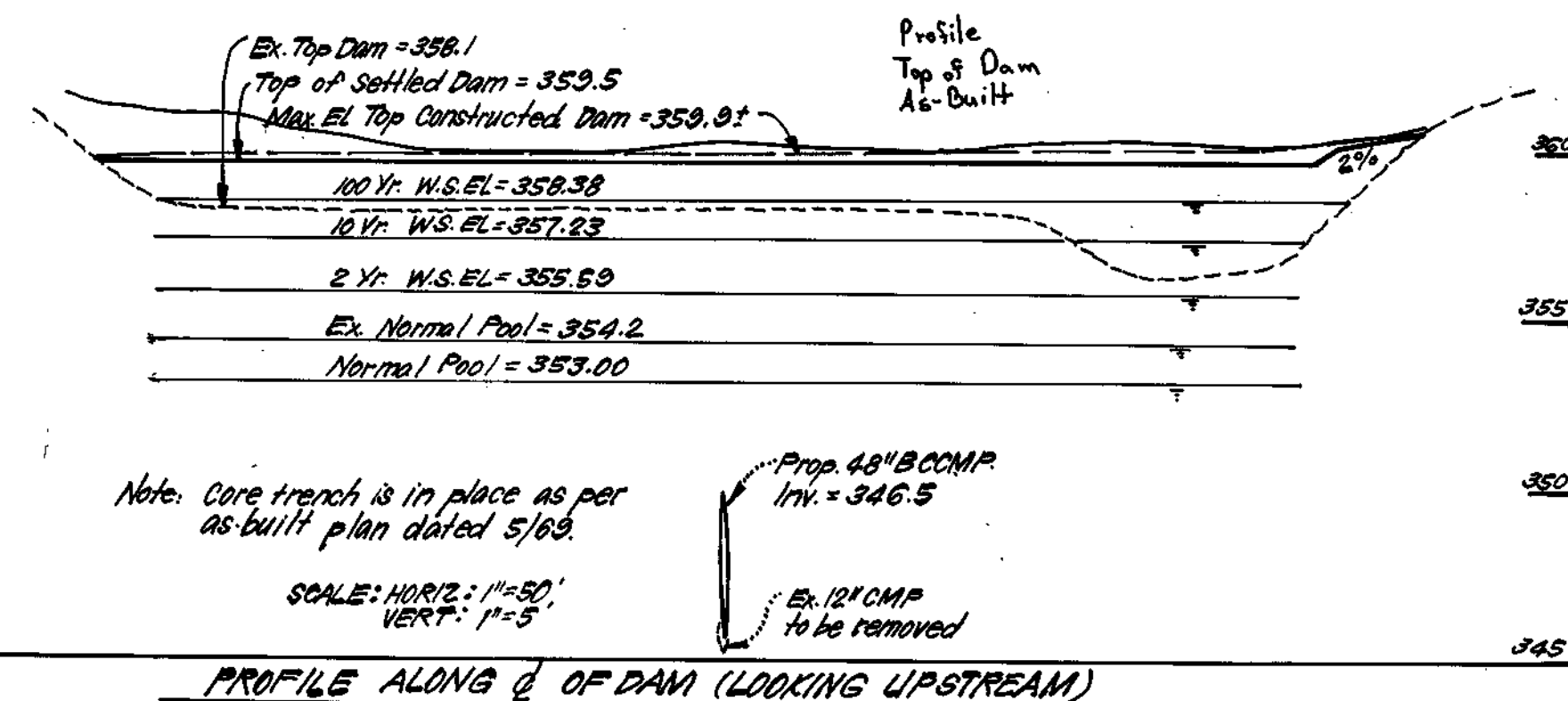

- 1. Grading Permits shall be obtained prior to installation of Sediment Control & Grading.
- 2. All Sediment and Erosion Control Measures will be installed and stabilized according to this plan prior to any other grading, clearing or disturbance of the existing surface of the site. See note #6 for stabilization except that the seed mixture will be annual ryegrass applied at a rate of 1.4 lbs./1000 sf.
- 3. Notify the Bureau of Inspections and Permits at least 24 hours before starting any work.
- 4. All Sediment Control Practices to conform to the "Standards and Specifications for Soil Erosion and Sediment Control in Developing Areas" and shall be adjusted to meet actual field conditions.
- 5. Stabilization of Disturbed ground to be done as soon after construction as possible.
- 6. All disturbed areas to be stabilized in accordance with the following Specifications:
 - A. Seed - certified 85% germination applied at the rate of 3 lbs./1000 sf. Mixture - 40% Kentucky Blue, 20% chewing Fescue, 20% Kentucky 31 and 20% annual ryegrass.
 - B. Fertilizer - 10-10-10 applied at a rate of 23 lbs./1000 sf. Ground Agricultural Lime or Dolomitic Lime applied at a rate of 30 lbs./1000 sf.
 - C. Mulch - Weed free grain straw applied at a rate of 70-90 lbs./1000 sf. Mulch shall be secured to the ground by any approved method i.e.; asphalt tacks, chemical binder etc.
 - D. All Sod used shall be Maryland State Certified.
- 7. All structural Sediment Control Measures are to remain in place until permission for their removal has been obtained from the Bureau of Inspections and Permits.
- 8. On-Site Inspection and Maintenance of all Sediment Control Measures including clean out of Sediment Traps and Dikes, and proper establishment of all planned vegetative measures will be the responsibility of the developer or his representative on the site, on a continuing day to day basis.
- 9. It will be the developer's responsibility to provide additional Sediment & Erosion Control Devices to protect stabilized areas during construction.
- 10. The Contractor shall keep all public roads free of sediment deposits left from traffic leaving construction site.
- 11. Approval of this plan is conditional upon the approval of Sediment Control Plan for the off-site waste or borrow area prior to the import of any borrow or export of waste to or from this site.
- 12. All pipes to be blocked at the end of each day. See detail this sheet (V/A)
- 13. Total Amount of Straw Bales or Silt Fence shown = NONE LF
- 14. SITE ANALYSIS:
 - A. Total Area = 15.062 Acres.
 - B. Area to be Reroled = NONE Acres.
 - C. Area to be Paved = 1.758 Acres.
 - D. Area to be Seeded = 5.175 Acres.
 - E. Area Undisturbed = 8.129 Acres.

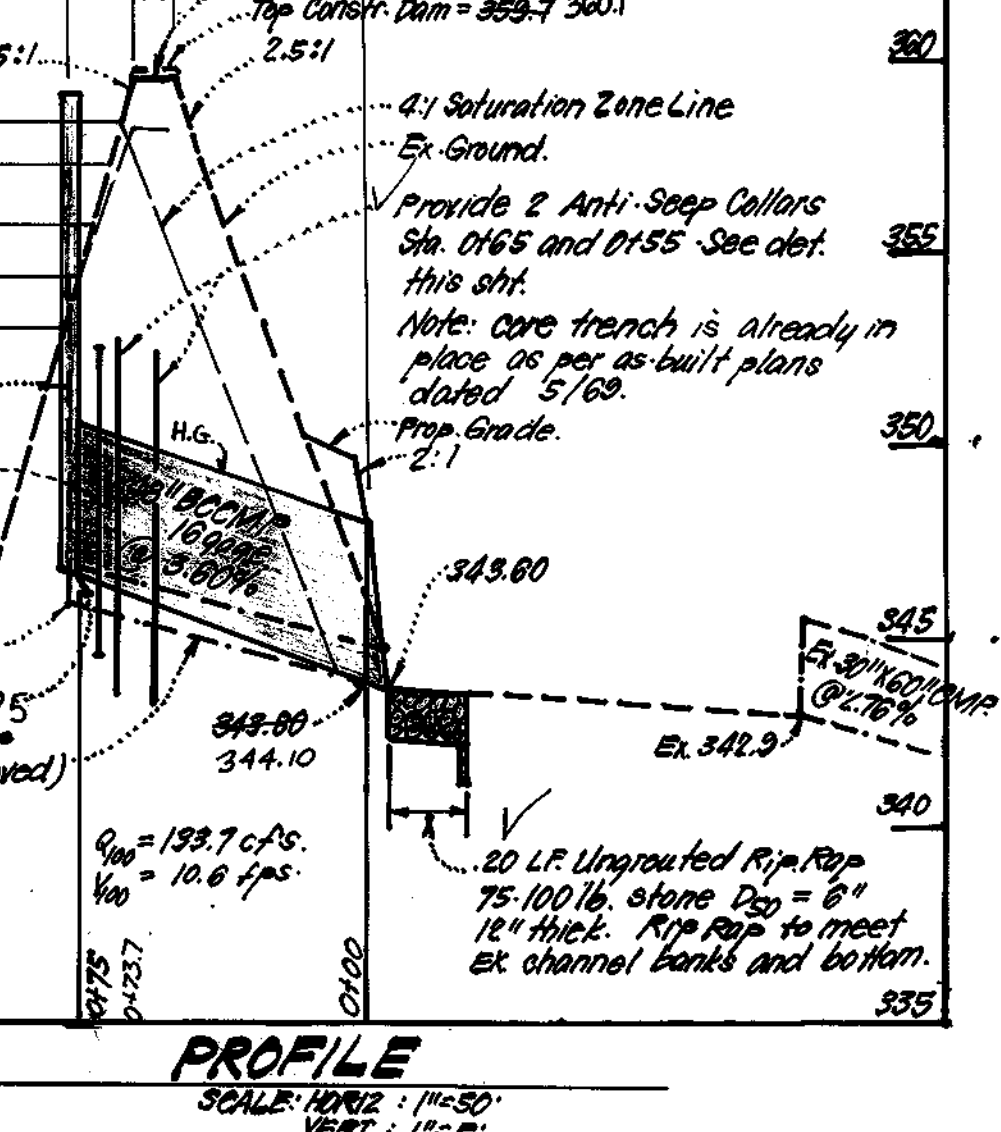
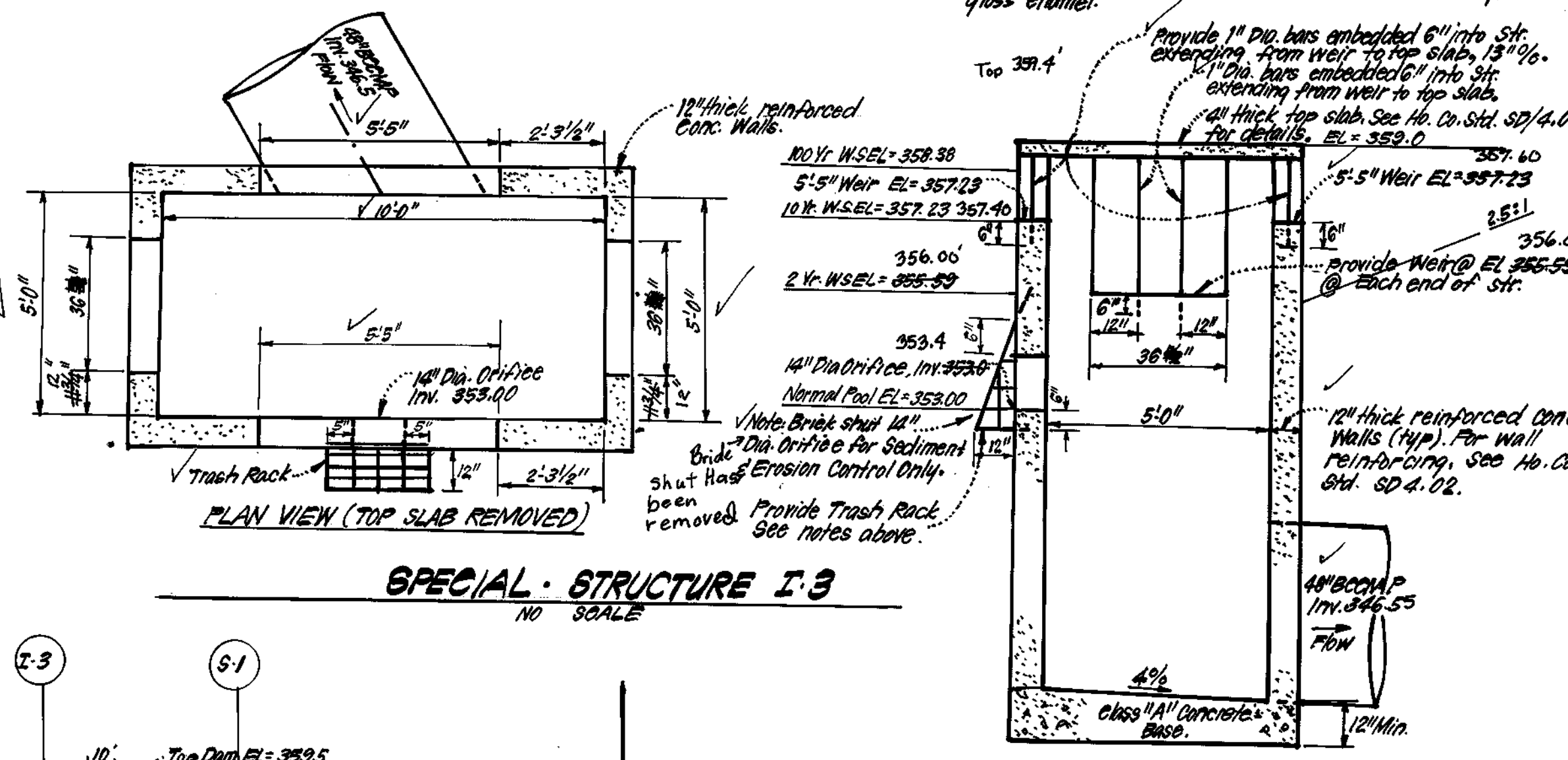

TRASH RACK NOTES:
 (1) Trash rack to be made of 1/2" dia. bars, welded together, 6" o.c.
 (2) Trash rack to be connected to structure by embedding bars 6" into walls.
 (3) After fabrication, trash rack to be painted with 1 coat rust preventive Alkyd primer and 2 coats Black Alkyd gloss enamel.

These plans have been reviewed for the Howard Soil Conservation District and meet the technical requirements for small pond construction, soil erosion and sediment control.
 Approved: *[Signature]* 8-16-84
 Date: 8-16-84

ENGINEER'S CERTIFICATE
 "I certify that this plan for pond construction, erosion, and sediment control represents a practical and workable plan based on my personal knowledge of the site conditions. This plan was prepared in accordance with the requirements of the Howard Soil Conservation District. I have notified the developer that he must provide the Howard Soil Conservation District with a red-lined "as built" of the pond within 30 days of completion."
 Signature of Engineer: *[Signature]* 6-19-84
 Date: 6-19-84

DEVELOPER'S CERTIFICATE
 "I certify that all development and/or construction will be done according to these plans of development, pond construction and erosion and sediment control. I also authorize periodic on-site inspection by the Howard Soil Conservation District or their authorized agents, as are deemed necessary. Deviation from this plan will not be made unless authorized by The Howard Soil Conservation District. I will provide the Howard Soil Conservation District with a red-lined "as built" of the pond within 30 days of completion."
 Signature of Developer: *[Signature]* 6/20/84
 Date: 6/20/84

No.	REVISION	DATE
1	Added concrete collar around 48" BOCMP.	10-26-84

APPROVED: DEPARTMENT OF PUBLIC WORKS
 Chief, Bureau of Engineering: *[Signature]* 8-17-84
 APPROVED: HOWARD COUNTY OFFICE OF PLANNING & ZONING
 Acting Chief, Division of Land Development & Zoning Administration: *[Signature]* 8-16-84

CLARK · FINEFROCK & SACKETT
 ENGINEERS · PLANNERS · SURVEYORS
 11315 LOCKWOOD DRIVE · SILVER SPRING, MARYLAND 20904 · (301) 593-3400

DESIGNED	ULS	SCALE	AS SHOWN
DRAWN	K/W	DRAWING	4 OF 4
CHECKED	ULS	JOB NO.	83-076
DATE	6-18-84	FILE NO.	83-076-D

ROAD CONSTRUCTION PLANS
 STORM WATER MANAGEMENT NOTES &
 SEDIMENT & EROSION CONTROL NOTES
SEWELLS ORCHARD
 SECTION 3 AREA 1
 6TH ELECTION DISTRICT
 HOWARD COUNTY, MARYLAND
 FOR: ORCHARD ASSOCIATES
 P.O. Box 913
 Columbia Md. 21044

6/19/84 F-24-215