

CONSTRUCTION DETAILS

1. INSTALL 6' X 30' LOOP DETECTOR (QUADRUPOLE).
2. INSTALL SIGNAL HEAD ON EXISTING SPAN WIRE.
3. REMOVE EXISTING SIGNAL HEAD.
4. REMOVE EXISTING CONTROLLER, CABINET AND FOUNDATION.
5. INSTALL 2" PVC CONDUIT (TRENCHED). OMIT
6. INSTALL 1" GAL. STEEL SLEEVE.
7. INSTALL 7 CONDUCTOR CABLE FOR SIGNAL HEAD 1.
8. INSTALL TWO 4" PVC CONDUITS (TRENCHED).
9. INSTALL CONTROLLER, CABINET AND FOUNDATION AND RELOCATE EXISTING CABLES AND POWER FEED TO NEW CABINET
10. INSTALL SIGN "A" NEXT TO SIGNAL HEAD.

GENERAL NOTES

1. THE HIGHWAY MARKING AND SIGNING SHALL BE THE RESPONSIBILITY OF OTHERS, EXCEPT AS NOTED.
2. THE UTILITIES SHOWN ON THE CONSTRUCTION PLAN ARE SCHEMATIC ONLY AND ARE NOT TO BE CONSIDERED COMPLETE. THE CONTRACTOR SHALL BE RESPONSIBLE FOR NOTIFYING ALL UTILITY COMPANIES PRIOR TO CONSTRUCTION SO THAT ALL UTILITIES CAN BE LOCATED IN THE FIELD. THE CONTRACTOR SHALL LOCATE EXISTING UTILITIES A MINIMUM OF TWO (2) WEEKS IN ADVANCE OF THE CONSTRUCTION OPERATIONS IN THE VICINITY OF THE UTILITIES. ANY DAMAGE INCURRED BY THE CONTRACTOR SHALL BE REPAIRED IMMEDIATELY AT THE CONTRACTOR'S EXPENSE. THE CONTRACTOR SHALL NOTIFY THE FOLLOWING UTILITIES OR AGENCIES AT LEAST FIVE (5) DAYS BEFORE STARTING WORK SHOWN ON THESE PLANS:

- MISS UTILITY (COLLEGT) 1-559-0100
- BALTIMORE GAS & ELECTRIC COMPANY UNDERGROUND ELECTRIC DISTRIBUTION ENGINEERING "DAMAGE CONTROL" 231-5691
- BALTIMORE GAS & ELECTRIC COMPANY - UNDERGROUND GAS DISTRIBUTION ENGINEERING "DAMAGE CONTROL" 231-5533
- CHESTER AND POTOMAC TELEPHONE COMPANY 752-9976
- TRAFFIC DIVISION 992-2072
- HOWARD COUNTY CABLE T.V. 461-1156
- BUREAU OF UTILITIES - HOWARD COUNTY 992-2366

3. CONSTRUCTION SHALL BE COMPLETED IN ACCORDANCE WITH HOWARD COUNTY STANDARD SPECIFICATIONS AND DETAILS FOR CONSTRUCTION DESIGN MANUAL VOLUME IV.
4. ALL NEW SIGNAL HEADS SHALL BE SECURELY WRAPPED AND/OR BAGGED IN OURLAP, PRIOR TO SIGNAL BEING PLACED IN SERVICE.
5. THE CONTRACTOR SHALL COMPLY WITH OSHA AND MSHA CODES.
6. THE CONTRACTOR SHALL COMPLY WITH THE FOLLOWING: MAINTAIN SIX (6) INCHES MINIMUM CLEARANCE WITH ALL UNDERGROUND UTILITIES AND ALL OVERHEAD CLEARANCES SHALL BE IN ACCORDANCE WITH THE MARYLAND HIGH VOLTAGE ACT.
7. THE CONTRACTOR WILL SUPPLY ALL OTHER HARDWARE AND AUXILIARY EQUIPMENT REQUIRED FOR THE COMPLETION OF THE PROJECT AND ENSURE PROPER SIGNAL OPERATION AS DESIGNED AND SHOWN ON THESE PLANS.
8. THE ELECTRICAL FEED AND SOURCE FOR THE TRAFFIC SIGNALS SHOULD BE SEPARATE FROM POWER FEED FOR THE LUMINAIRES.

CONTROLLER AND ACCESSORIES

1. NEMA EIGHT PHASE MODULAR CONTROLLER WITH SOLID STATE CIRCUITRY AND DIGITAL TIMING, SIMILAR TO EGONLITE KMG E-0000 SERIES DIGITAL CONTROLLER UNIT, EQUIVALENT MANUFACTURED BY GROUSE-HINDS, EAGLE SIGNAL CORPORATION OR APPROVED EQUAL SHALL BE INSTALLED WITH THE FOLLOWING:
 - A. FOUR PHASE SIGNAL OVERLAP CAPABILITY.
 - B. VEHICULAR ACTUATED MODULE WITH VOLUME DENSITY CONTROLS FOR TWO APPROACHES.
 - C. VEHICULAR ACTUATED MODULES (CAPABLE OF CONTROLLING SIX TRAFFIC MOVEMENTS).
 - D. VEHICULAR ACTUATED PHASE MODULES SHALL BE CAPABLE OF THE FOLLOWING FUNCTIONS: MINIMUM GREEN, PASSAGE TIME, YELLOW, ALL RED CLEARANCE, DUAL MAXIMUM, PEDESTRIAN TIMING, RECALL AND MEMORY.
 - E. VEHICULAR ACTUATED PHASE MODULE WITH VOLUME DENSITY CONTROLS SHALL BE CAPABLE OF THE FOLLOWING FUNCTIONS: MINIMUM GREEN, PASSAGE TIME, YELLOW, ALL RED CLEARANCE, DUAL MAXIMUM, PEDESTRIAN TIMING, SECONDS PER ACTUATION, TIME TO REDUCE, TIME FOR REDUCTION, MINIMUM GAP, RECALL AND MEMORY.
2. A CONFLICT MONITOR FOR ALL PHASES AND SOLID STATE LOAD SWITCHES SHALL BE FULLY WIRED IN THE CABINET.
3. A SOUND MOUNTED TRAFFIC CONTROLLER CABINET LARGE ENOUGH TO ACCOMMODATE THE ABOVE CONTROL EQUIPMENT AND DETECTORS SHALL BE INSTALLED. THE CABINET SHALL BE FURNISHED WITH A THERMOSTATICALLY CONTROLLED CABINET VENT FAN.
4. THE FINISH OF THE CABINET SHALL BE ALL-WEATHER BRONZE PAINT.
5. THE CONTROLLER SHALL BE WIRED WITH FIVE 2 CHANNEL LOOP DETECTOR AMPLIFIERS (DISPLAY OUTPUT TYPE) AND HARNESSSES.
6. A METER BOX SHALL BE INSTALLED IN A VANDAL PROOF ENCLOSURE PROVIDED BY THE CONTRACTOR. THE FINISH OF THE METER BOX, HOUSING AND CONDUITS SHALL BE ALL-WEATHER BRONZE PAINT.
7. ALL PHASES SHALL BE SKIPPABLE.

UNDERGROUND WIRING

1. UNDERGROUND WIRING UNDER ROAD SURFACES SHALL BE PLACED IN NEW GALVANIZED CONDUITS PUSHED UNDER THE ROAD SURFACE. P.V.C. ELECTRICAL CONDUIT IN GRASS MEDIAN SHALL BE TRENCHED AS SPECIFIED AND AS SHOWN ON THE CONTRACT DRAWINGS.

LOOPS AND DETECTORS

1. THE FOLLOWING NEW LOOPS SHALL BE INSTALLED:

PHASE	DIMENSIONS	NO. OF LOOPS REQUIRED
S	6' X 30'	1
2. ALL WIRING AND SAW CUTS SHALL BE IN ACCORDANCE WITH MANUFACTURER'S RECOMMENDATIONS FOR CORRECT OPERATION.
3. PHASES 1, 3, 4, 5, 7, 8 SHALL OPERATE IN THE PRESENCE MODE. PHASES 2 AND 6 SHALL OPERATE BY EXTENSION PHASE DETECTION.
4. DETECTOR AMPLIFIERS SHALL BE SARASOTA 235-T OR EQUIVALENT MANUFACTURED BY EGONLITE CONTROL PRODUCTS, INC., GROUSE-HINDS, OR APPROVED EQUAL.

SIGNAL HEADS

1. THE CONTRACTOR SHALL PROVIDE THE FOLLOWING SIGNAL HEADS: SIGNAL HEAD NOS. 1, 3, 5, 7 - ONE WAY, FIVE SECTION 12" SIGNAL HEAD HAVING RED, YELLOW, GREEN, YELLOW ARROW, GREEN ARROW INDICATIONS WITH TUNNEL VISORS INCLUDING PROPER ADJUSTABLE RIGID MOUNTING BRACKETS FOR SPAN WIRE MOUNTED INSTALLATION.
2. ALL SIGNALS SHALL BE PAINTED FEDERAL YELLOW WITH M.A. BRONDER AND SON'S, INC. SEASHORE GLOSS TRIM 27721, DURANDIC BRONZE, CODE 7557501 OR EQUAL.
3. SIGNAL HEAD LOCATIONS AND AIMING TO BE DETERMINED IN THE FIELD WITH THE ENGINEER.

CONSTRUCTION SEQUENCE

1. INSTALL NEW SIGNAL HEADS, CABLES, SIGNS, CONDUIT, LOOP DETECTORS, CONTROLLER, CABINET AND FOUNDATION. NEW SIGNAL HEADS AND SIGNS SHALL BE SECURELY WRAPPED OR BAGGED IN OURLAP.
2. TURN OFF EXISTING SIGNAL AT THE DIRECTION OF THE ENGINEER. THE CONTRACTOR SHALL ARRANGE FOR POLICE ASSISTANCE FOR TRAFFIC CONTROL WHEN THE SIGNAL IS NOT IN OPERATION.
3. RELOCATE EXISTING CABLES AND POWER FEED TO NEW CONTROLLER.
4. REMOVE SIGNAL HEADS ADJACENT TO HEADS 1, 3, 5, AND 7.
5. UNCOVER NEW SIGNAL HEADS AND SIGNS.
6. ENERGIZE SIGNALS.
7. REMOVE EXISTING CONTROLLER, CABINET AND FOUNDATION.

SIGN "A"

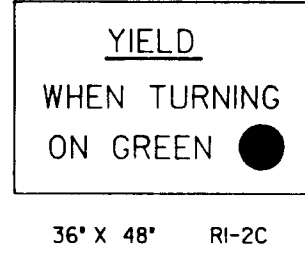

36" X 48" RI-2C

NEMA PHASING

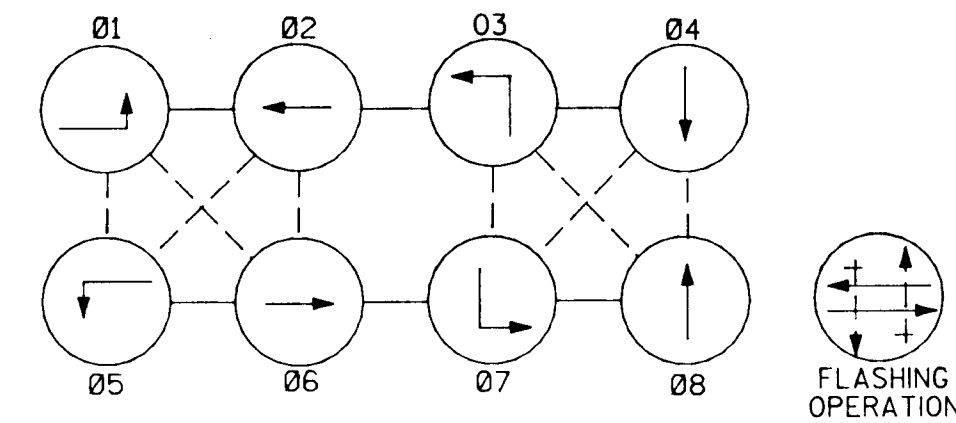

1. PHASES ASSOCIATED BY A SOLID LINE WILL NOT OPERATE CONCURRENTLY.
2. PHASES ASSOCIATED BY A DASHED LINE MAY WILL OPERATE CONCURRENTLY.

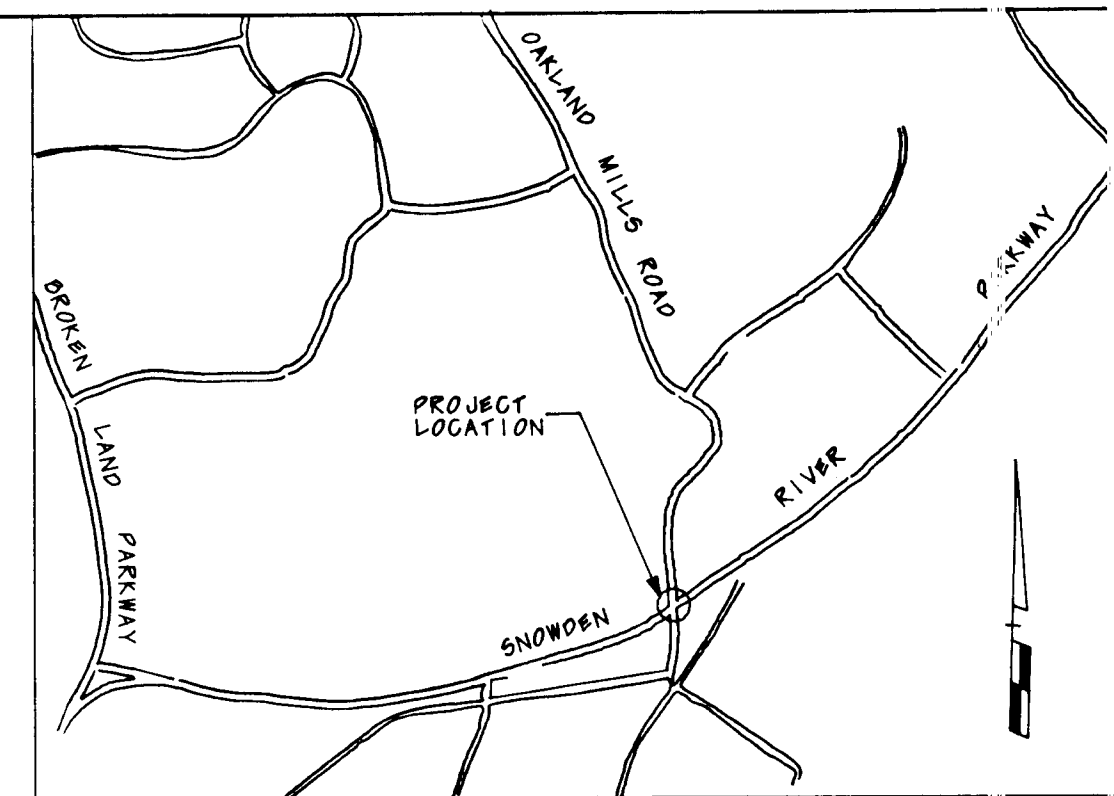

LEGEND

- | | |
|----------|------------------------------|
| EXISTING | PROPOSED |
| | SIGNAL HEAD |
| | HANDBOX |
| | LOOP DETECTOR |
| | CONTROL CABINET W/ METER BOX |
| | SIGNAL POLE |
| | CONDUIT |

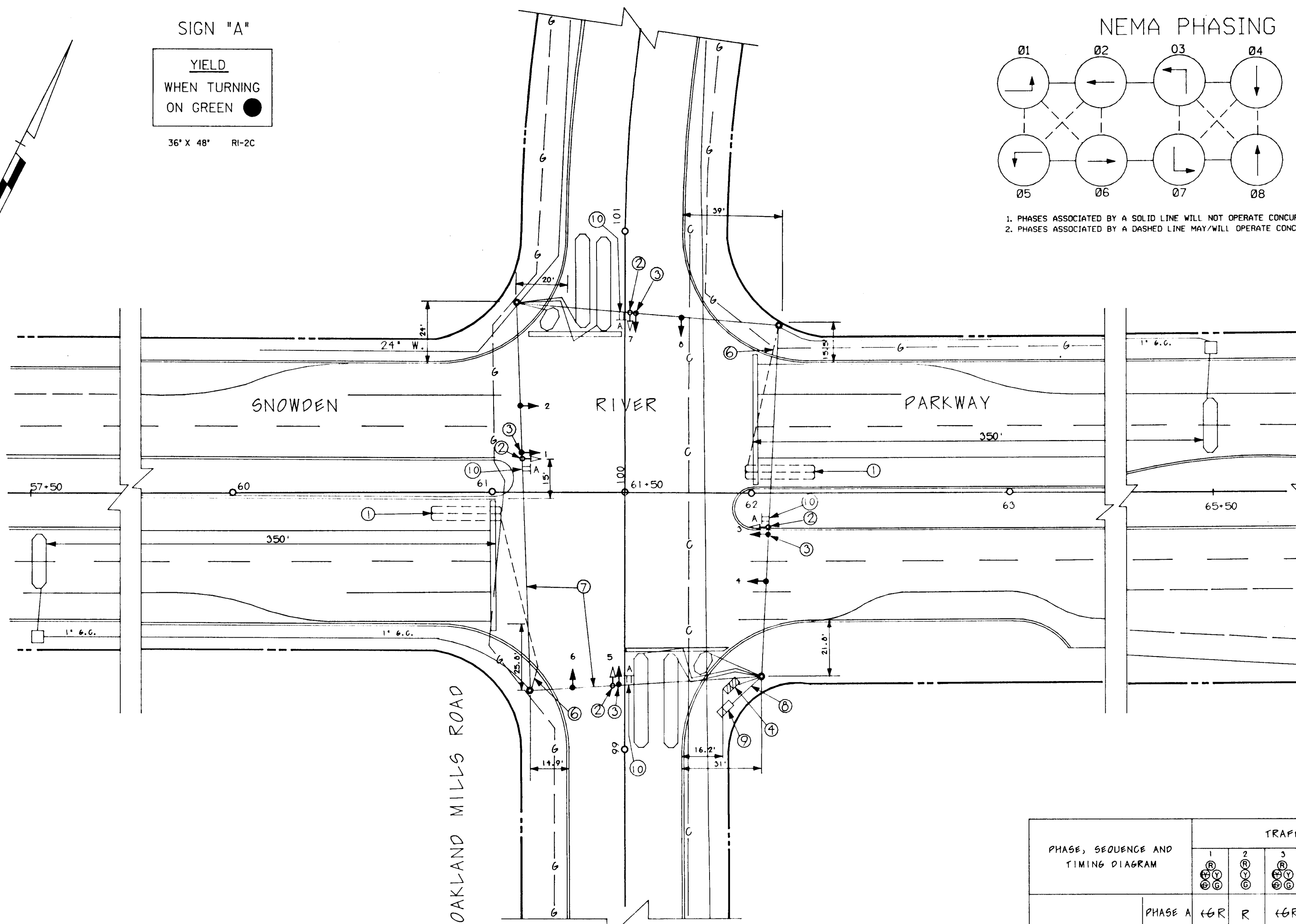

SCALE
1" = 30'

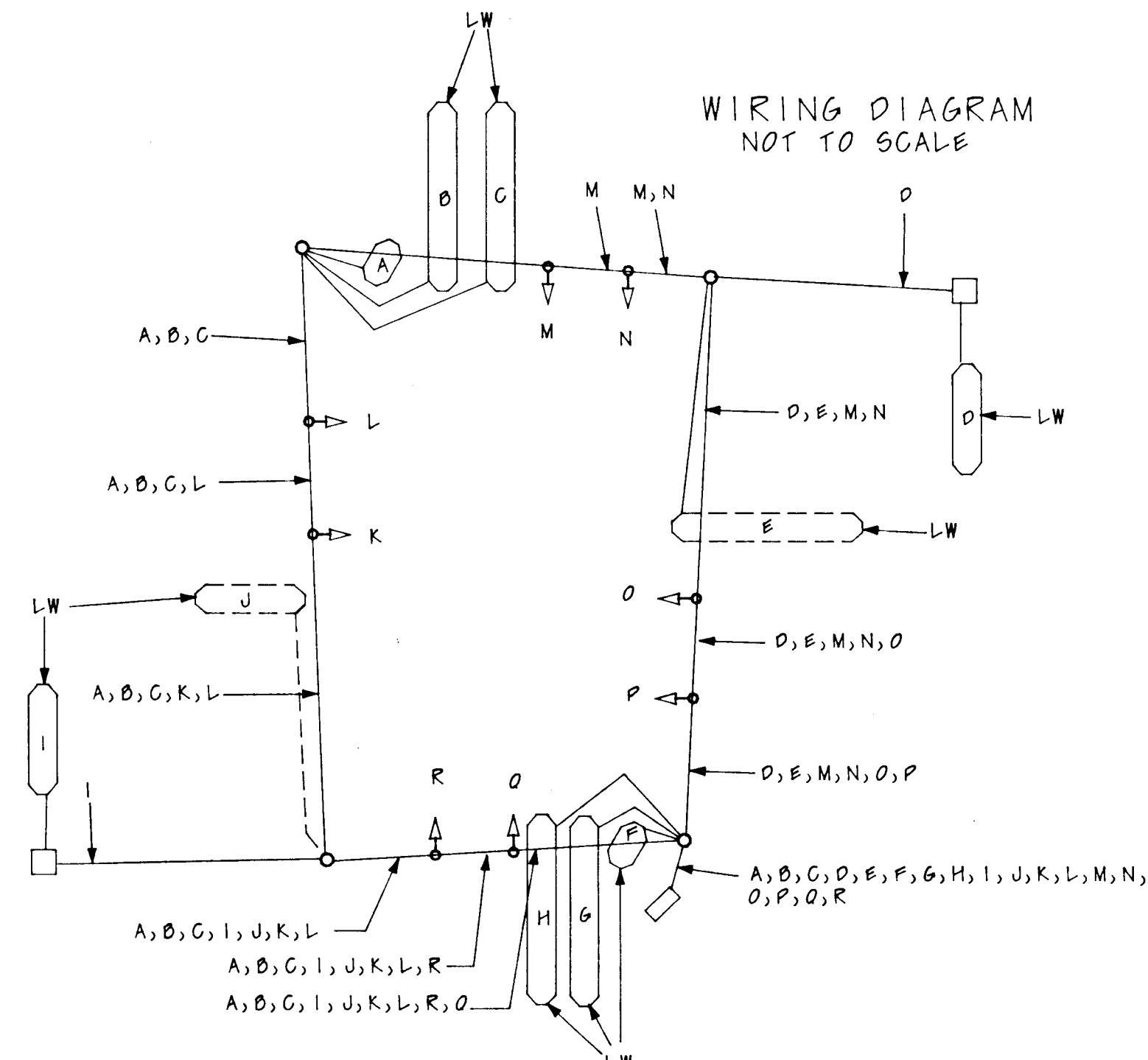

- A : EXISTING 2 CONDUCTOR CABLE (SHIELDED)
- B : .
- C : .
- D : .
- E : 2 CONDUCTOR CABLE (ALUMINUM SHIELDED)
- F : EXISTING 2 CONDUCTOR CABLE (SHIELDED)
- G : .
- H : .
- I : .
- J : 2 CONDUCTOR CABLE (ALUMINUM SHIELDED)
- K : 7 CONDUCTOR CABLE (NO. 14 A.W.G.)
- L : EXISTING 5 CONDUCTOR CABLE
- M : 7 CONDUCTOR CABLE (NO. 14 A.W.G.)
- N : EXISTING 5 CONDUCTOR CABLE
- O : 7 CONDUCTOR CABLE (NO. 14 A.W.G.)
- P : EXISTING 5 CONDUCTOR CABLE
- Q : 7 CONDUCTOR CABLE (NO. 14 A.W.G.)
- R : EXISTING 5 CONDUCTOR CABLE

PHASE, SEQUENCE AND TIMING DIAGRAM	TRAFFIC SIGNAL HEADS								MIN. GREEN	PASSAGE YELLOW	PED. CLEAR	MAX. I	MAX. II	SECONDS PER ACTUATION	TIME TO REDUCTION	TIME BEFORE REDUCTION	MIN. GAP	RECALL	MEMORY
	1	2	3	4	5	6	7	8											
PHASE A CLEAR	←R	R	←R	R	R	R	R	R	3	3		15	10					OFF	ON 1.2CK
PHASE B CLEAR	←G	G	←R	R	R	R	R	R	3	3		15	10						
PHASE C CLEAR	←Y	Y	←Y	Y	←R	R	R	R	3	3		15	10						
PHASE D CLEAR	←R	R	←G	G	←R	R	R	R	3	3		15	10						
PHASE E CLEAR	←R	R	←Y	Y	←R	R	R	R	3	3		15	10						
PHASE F CLEAR	←R	R	←R	R	←G	G	←G	G	5	4		20	15					OFF	1.2CK
FLASH OPER.	FL/Y	FL/Y	FL/Y	FL/Y	FL/R	FL/R	FL/R	FL/R											

C1140B01

DEPARTMENT OF PUBLIC WORKS
HOWARD COUNTY, MARYLAND

DIRECTOR OF PUBLIC WORKS: *Philip H. Anderson* DATE: 3/10/06
 CHIEF, BUREAU OF ENGINEERING: *Robert E. ...* DATE: ...

GREENHORNE & O'MARA, INC.
9001 EDMONSTON ROAD, GREENBELT, MARYLAND 20770
(301) 982-2880

REGISTERED PROFESSIONAL ENGINEER

DES: J. C. K.
 DRN: J. C. K.
 CHK: J. A. D.
 DATE: 2/20/06

BY	NO.	REVISION	DATE

TRAFFIC SIGNAL PLAN
TF 213

600' SCALE MAP NO. _____ BLOCK NO. _____

SNOWDEN RIVER PARKWAY AND OAKLAND MILLS ROAD
CAPITAL PROJECT T-7036
HOWARD COUNTY, MARYLAND

SCALE AS SHOWN
SHEET OF 1